

APRIL 2020

SUPPLEMENTARY MASTER MUNICIPAL CONSTRUCTION DOCUMENTS

SUPPLEMENTARY
GENERAL CONDITIONS

SUPPLEMENTARY
SPECIFICATIONS

SUPPLEMENTARY
STANDARD DRAWINGS

ENGINEERING DEPARTMENT





Engineering Department

**Supplementary Master
Municipal Construction Documents**

**SUPPLEMENTARY GENERAL
CONDITIONS**

April 2020

The City of Surrey Supplementary Master Municipal Construction Documents are supplemental to the **Master Municipal Construction Document – Platinum Edition (2009)** and take precedence over the General Conditions, Specifications, Standard Detail Drawings and their Amendments.

TABLE OF CONTENTS

	<u>PAGE</u>
1.0 DEFINITIONS.....	1
1.1 ABNORMAL WEATHER	1
1.76 VARIANCE THRESHOLD PERCENTAGE	1
1.79 ARCHAEOLOGICAL ARTIFACTS.....	1
1.80 COMMENCEMENT DATE	1
1.81 FOREIGN MATERIAL.....	1
1.82 HIGHWAY	1
1.83 PUBLIC ART.....	1
1.84 SUPPLEMENTARY GENERAL CONDITIONS (SGC)	2
1.85 SUPPLEMENTARY GENERAL CONDITIONS, PROJECT (SGCP).....	2
1.86 SUPPLEMENTARY SPECIFICATIONS (SS)	2
1.87 SUPPLEMENTARY SPECIFICATIONS, PROJECT (SSP)	2
1.88 UTILITIES.....	2
1.89 MUNICIPAL UTILITIES.....	2
2.0 DOCUMENTS	3
2.1 EXECUTION	3
2.2 INTERPRETATION.....	3
4.0 CONTRACTOR	3
4.1 CONTROL OF WORK.....	3
4.2 SAFETY	4
4.3 PROTECTION OF WORK, PROPERTY AND THE PUBLIC	4
4.6 CONSTRUCTION SCHEDULE	8
4.7 SUPERINTENDENT.....	8
4.12 TESTS AND INSPECTIONS.....	9
7.0 CHANGES.....	9
7.4 OPTIONAL WORK.....	9
10.0 FORCE ACCOUNT.....	9
10.1 FORCE ACCOUNT COSTS.....	9
11.0 CONCEALED OR UNKNOWN CONDITIONS	10
11.1 DEFINITION	10
11.4 ACKNOWLEDGMENT	10
11.5 ARCHAEOLOGICAL ARTIFACTS.....	11
12.0 HAZARD MATERIALS	11
12.2 DISCOVERY OF HAZARDOUS MATERIALS.....	11
12.4 CONTRACT ADJUSTMENT FOR HAZARDOUS MATERIALS	11
13.0 DELAYS.....	11
13.8 DIRECTION TO STOP OR DELAY	11
13.9 LIQUIDATED DAMAGES FOR LATE COMPLETION.....	12

15.0	OWNER'S RIGHT ON CONTRACTOR'S DEFAULT	13
15.2	NOTICE OF DEFAULT	13
15.3	TERMINATION	13
16.0	CONTRACTOR'S RISK ON OWNER'S DEFAULT	14
16.2	WORK STOPPAGE	14
16.4	TERMINATION	14
17.0	DISPUTES	15
17.5	REFEREE	15
18.0	PAYMENT	15
18.5	PAYMENT	15
20.0	LAWS, NOTICES, PERMITS, AND FEES	16
20.2	PERMITS	16
20.4	FEES	16
21.0	WORKERS COMPENSATION REGULATION	16
21.1	EVIDENCE OF COMPLIANCE	16
21.2	CONTRACTOR IS "PRIME CONTRACTOR"	17
21.3	COMPLIANCE WITH WORKERS COMPENSATION REQUIREMENTS	18
22.0	INDEMNIFICATION	19
22.1	CONTRACTOR TO INDEMNIFY	19
24.0	INSURANCE	19
24.1	REQUIRED INSURANCE	19
27.0	PATENTS AND COPYRIGHTS	21
27.1	PATENT AND COPYRIGHT COMPLIANCE	21
28.0	NON-RESIDENTS	21
28.1	NON-RESIDENTS	21

1.0 DEFINITIONS

1.1 Abnormal Weather	Delete 1.1.1 and replace with	“Abnormal Weather” means temperature, precipitation, wind or other weather condition, as determined by the Contract Administrator, that prevents the <i>Contractor</i> from proceeding with at least 60% of the normal labour and equipment force, for at least 5 hours on a component of the work, which if delayed is on the critical path of the schedule and as such will delay the completion of the Work.
1.76 Variance Threshold Percentage	Delete 1.76.1 and replace with	“ <i>Variance Threshold Percentage</i> ” means a variance of 15% between the quantity of a unit price item actually constructed or provided by the time of <i>Total Performance</i> and the quantity shown on the tendered <i>Schedule of Quantities and Prices</i> for that item. <i>Variance Threshold Percentage</i> is not applicable to any items that are paid through units such as ‘lump sum’, or ‘each’.
1.79 Archaeological Artifacts	Add 1.79.1	"Archaeological Artifacts" means any fossils, artifacts, coins, articles of value or antiquity, remains, and other things of geological, archaeological or historical interest or value discovered at the Place of the Work.
1.80 Commencement Date	Add 1.80.1	“Commencement Date” has the meaning set out in paragraph 5.1.2 of the Form of Tender.
1.81 Foreign Material	Add 1.81.1	“Foreign Material” with respect to SGC 11.0 is limited specifically to the following: multiple layers of asphalt or concrete pavement and masses resulting in a cumulative thickness in excess of 300mm; buried railway ties and tracks; and buried corduroy roads, homogenous rocks having an individual volume greater than 1 cubic metre. It does not include <i>Utilities</i> , stumps and other subsurface conditions.
1.82 Highway	Add 1.82.1	“Highway” includes a street, road, lane, bridge, thoroughfare, sidewalk, boulevard, viaduct and any other way open to public use.
1.83 Public Art	Add 1.83.1	“Public Art” means publicly accessible original art that the <i>Owner</i> separately contracts and is created and/or installed at or near the Work.

Apr. 2020

Apr. 2020

1.84 Supplementary General Conditions (SGC)	Add 1.84.1	SGC means those City of Surrey Supplementary General Conditions (SGC's), made up of paragraphs and subparagraphs with the same numbering as the Master Municipal Construction Documents, which are supplementary to and superseding to GC's.
1.85 Supplementary General Conditions, Project (SGCP)	Add 1.85.1	SGCP means project specific supplementary general conditions, made up of paragraphs and subparagraphs with the same numbering as the Master Municipal Construction Document, which are supplementary to and superseding SGC's and GC's.
1.86 Supplementary Specifications (SS)	Add 1.86.1	SS means those City of Surrey Supplementary Specifications (SS), made up of paragraphs and subparagraphs with the same numbering as the Master Municipal Construction Documents, which are supplementary to and superseding the Master Municipal Specifications.
1.87 Supplementary Specifications, Project (SSP)	Add 1.87.1	SSP means project specific supplementary specifications, made up of paragraphs and subparagraphs with the same beginning paragraph numbers as the Master Municipal Construction Document, which are supplementary to and superseding the SS's and Master Municipal Specifications.
1.88 Utilities	Add 1.88.1	<i>"Utilities"</i> is used broadly and includes but is not limited to any and all lines, poles, structures, facilities, infrastructure works, utilities for power, cable TV, telephone, telecommunications and data transmission, all sanitary and drainage infrastructure, all water, oil, gas and electric services, all steam pipes and services, all survey monuments, street lights, traffic lights, traffic detector loops embedded in pavement, rail tracks, and all related infrastructure, whether located above or below ground, whether visible or invisible, whether man-made or natural.
1.89 Municipal Utilities	Add 1.89.1	<i>"Municipal Utilities"</i> includes all utilities under the ownership of the <i>Owner</i> .

2.0 DOCUMENTS

2.1 Execution

Delete 2.1.1 and
replace with

The *Owner* shall deliver the *Contract Documents*, in a form ready for signing, to the *Contractor* within 15 *Days* after receipt of all information required to be submitted by the *Contractor* as set out in paragraph 5.1.1 of the Form of Tender.

2.2 Interpretation

Delete 2.2.4(1)
and replace
with

(1) the *Contract Documents* shall govern and take precedence in the following order with the Agreement taking precedence over all other *Contract Documents*:

- a) Agreement
- b) Addenda
- c) Supplementary General Conditions, Project
- d) Supplementary General Conditions
- e) General Conditions
- f) Supplementary Specifications, Project
- g) Supplementary Specifications
- h) Specifications
- i) Drawings list in Schedule 2 to the Agreement
- j) Supplementary Detail Drawings
- k) Standard Detail Drawings
- l) Executed Form of Tender
- m) Instructions to Tenderers
- n) All other *Contract Documents*;

4.0 CONTRACTOR

4.1 Control of Work

Append to 4.1.2

As the *Work* proceeds, or as directed by the *Contract Administrator*, remove and dispose of all rubbish and other deleterious material, remove false-work, forms, temporary structures, all equipment and machinery, and leave the *Work* in a clean, tidy and fully-restored condition. All curbing, sidewalks, drainage ditches and culverts, shrubs, fences and other surface properties that have been removed, damaged or disturbed in the performance of the *Work* shall be restored or replaced to a condition equivalent to that which existed before the *Work* began as determined by the Contract Administrator.

	Add 4.1.3	If the <i>Contractor</i> fails to clean up the <i>Site</i> when so ordered by the <i>Contact Administrator</i> , the <i>Owner</i> may proceed to do whatever is necessary to clean up and restore the <i>Site</i> and charge any and all costs thereof against the <i>Contractor</i> or deduct from payments owing to the <i>Contractor</i> .
4.2 Safety	Add 4.2.2	The <i>Contractor</i> shall, at its own expense and risk provide full, proper and safe access to, from and past buildings and properties, both for vehicles and pedestrians, and for this purpose construct and maintain, in good order and serviceable condition, suitable and convenient platforms, approaches, structures, bridges, crossings or similar works.
4.3 Protection of Work, Property and the Public	Delete 4.3.1 and replace with	In performing the <i>Work</i> the <i>Contractor</i> shall protect the <i>Work</i> , the <i>Owner's</i> property and other person's property from damage. The <i>Contractor</i> shall, at the <i>Contractor's</i> own expense, make good any such damage and indemnify the <i>Owner</i> from any loss or expense which arises as a result of the <i>Contractor's</i> operations.
	Delete 4.3.4 and replace with	<p>The <i>Owner</i> does not possess complete or accurate information with respect to the occurrence or the location of existing <i>Utilities</i> that will or may be encountered by the <i>Contractor</i> during the performance of the <i>Work</i>. Any plans, surveys, maps or descriptions of <i>Utilities</i> given to the <i>Contractor</i>, verbal or otherwise, are intended only as an aid to assist the <i>Contractor</i> in locating these construction obstacles. However, the <i>Contractor</i> is solely responsible to take all steps necessary to investigate, locate, verify and protect all <i>Utilities</i>.</p> <p>Before commencing <i>Work</i> the <i>Contractor</i> shall:</p> <ol style="list-style-type: none">(1) Complete a BC One Call at least 48 hours in advance.(2) Expose and determine conclusively in the field the location, elevation, dimensions and material type of all underground <i>Utilities</i> and structures indicated on the <i>Contract Documents</i> as being at the <i>Place of Work</i>.

- (3) Consult with all utility corporations that provide electricity, communication, gas or other utility services in the area of the Place of the Work, to similarly expose and conclusively determine the location of all underground *Utilities* for which they have records; and
- (4) Similarly expose and conclusively determine the location of any other *Utilities* or underground structures that are reasonably apparent in an inspection of the *Place of the Work*.

Append to 4.3.5

The *Contractor* hereby indemnifies and saves the *Owner*, its elected and appointed officials, employees and agents harmless from and against all liabilities, actions, causes of action, claims, damages, expenses, costs, debts, demands or losses suffered or incurred by them or any of them, including consequential damages and damages to third parties, whether known or unknown, foreseeable or not, for which the *Owner* or any of them might be liable arising from the provision of or failure to provide information regarding *Utilities*.

Delete 4.3.6 and
replace with

In performing *Work* on or near *Utilities*, or where it is necessary to cut, move or alter any *Utilities*, the *Contractor* shall communicate and make arrangements with the proper authorities and perform the *Work* in compliance with any direction or instruction received from that authority. Any damage to *Utilities* by the *Contractor* shall be repaired at the *Contractor's* expense. Where *Utilities* are serving the public while construction is in progress, it shall be the responsibility of the *Contractor* to plan and execute the *Work* such that there is no disruption of service by such *Utilities*.

Add 4.3.7 In performing *Work* on or near third-party *Utilities* (BC Hydro, CN Rail, CP Rail, Fiber Optic Fortis, Kinder Morgan, Metro Vancouver, Southern Rail, Shaw, Telus, etc.), or where it is necessary to cut, move or alter these *Utilities*, the *Contractor* shall communicate and coordinate with the third-party companies or authorities as it relates to schedule, timing, site safety and compliance in the utility alterations or relocations as part of performing the overall *Work*. If the alteration of these *Utilities* impacts the project schedule, the *Contractor* shall allow sufficient time for the companies or authorities to relocate their *Utilities*. It is the *Contractor's* responsibility to ensure all *Work*, including third-party utility relocations, is coordinated and completed in a reasonable time as part of the overall *Work*.

In the event the *Contractor* has been diligent and made significant effort and attempts in coordinating with the third-party companies or authorities and having their relocations accelerated, any and all costs incurred as a result of the third-party companies' ability, or inability, to relocate the *Utilities* are considered incidental and any such Delays are considered *Unavoidable Delays* as per GC 13.3 and beyond the reasonable control of the *Owner*.

Add 4.3.8 *Contractor* shall not deposit any material upon any Highway without first obtaining the approval of the *Contract Administrator* to the location, manner of placement, nature and amount of the material to be deposited and length of time for placement of the material.

Add 4.3.9 Where the *Work* is to be performed on private property, it is the responsibility of the *Owner* to arrange for and acquire required access. The *Contractor* shall not perform *Work* on any private property until the *Contract Administrator* has confirmed to the *Contractor* in writing that the *Work* thereon may proceed.

- Add 4.3.10 On completion of any work in a right-of-way or on private property, the *Contractor* shall deliver to the *Contract Administrator*, a formal release in writing, in a form provided by the *Owner*, signed by each owner of private property for work performed in a right-of-way or on private property for which the *Owner* did not arrange for access. The formal release will verify that the *Contractor* has cleaned up the private property to the owner's satisfaction and that the property owner(s) has no claim upon the *Contractor* or the *Owner* as a result of the *Work*.
- Add 4.3.11 The *Contractor* shall keep all portions of the *Work* properly and efficiently drained during construction until *Total Performance* and in compliance with any by-laws or requirements of the *Owner*.
- Add 4.3.12 The *Contractor* shall protect and maintain access to all existing utilities, properties, solid waste collection receptacles, and mailboxes at all times during construction, including a minimum 1.5m wide and flat accessible path with no safety concerns. If access cannot be maintained, the *Contractor* shall make suitable arrangement for access as requested by the *Contract Administrator*, including solid waste collection and delivery of mail to the residents affected.
- Add 4.3.13 The *Contractor* shall, at its own expense and risk, deliver to businesses and residents copies of letters provided to the *Contractor* by the *Owner*, advising these persons of intended construction activities. The *Contractor* shall deliver these letters no sooner than ten (10) *Days* and no later than five (5) *Days* before the start of construction in the affected area.
- Add 4.3.14 The *Contractor* is responsible for the maintenance and repair of any *Highway* affected by the *Work*, including *Highways* used for hauling, trucking and delivery.

Apr. 2020

	Add 4.3.15	<p><i>Work</i> on a <i>Highway</i> shall be carried out in such a manner that will not affect traffic on any <i>Highway</i> or prevent access to property fronting on the <i>Highway</i> without first having obtained written permission to do so from the authorities having jurisdiction. In that regard, the <i>Contractor</i> shall perform its <i>Work</i> in strict compliance with the requirements, rules, regulations and by-laws of any Federal, Provincial or municipal authority having jurisdiction.</p>
4.6 Construction Schedule	Add 4.6.8	<p>In instances where the <i>Contractor</i> is double-shifting, as determined to be either working longer than 12 hours per day or in any 24-hour period, then 2 <i>Days</i>, or <i>Work Days</i>, will be deducted from the <i>Contract Time</i> for every calendar day when such activity is completed.</p> <p>The <i>Contractor</i> may apply for exemptions to the noise by-law in order to perform portions of the <i>Work</i> at night, however the <i>Owner</i> does not guarantee that exemptions will be granted, nor shall the <i>Contractor</i> rely on exemptions being permitted in order to complete the <i>Work</i> in accordance with the <i>Construction Schedule</i>.</p>
4.7 Superintendent	Append to 4.7.2	<p>The <i>Superintendent</i> shall be in attendance at all times at the <i>Place(s) of the Work</i> unless permitted otherwise by the <i>Contract Administrator</i>.</p>
	Add 4.7.4	<p>Unless otherwise permitted by the <i>Owner</i>, the <i>Superintendent</i> shall be the person named in Appendix 3 in the tender submission documents.</p>

Apr. 2020

4.12 Tests and Inspections

Delete 4.12.1 and replace with

The *Contractor* is solely responsible for ensuring that the *Work* is performed in accordance with the requirements of the *Contract Documents*. The *Contractor* shall perform or cause to be performed all tests, inspections and approvals of the *Work* as required by the *Contract Documents* or as required by the *Contract Administrator* as part of the *Quality Control*. Any reference in the specifications to inspection and testing shall mean that the *Work* described in the specification must be inspected and tested in a manner approved by the Contract Administrator. The *Contractor* shall only employ or engage, as an agent or consultant for testing, a person approved by the *Owner*. Where the specification indicates that the *Contract Administrator* will arrange for testing, the *Contractor* continues to be solely responsible for testing of the *Work*. Upon immediate completion of each test, certified copies of each test shall be submitted by the testing laboratory directly to the *Contract Administrator*. The *Contract Administrator* may perform additional tests for the *Owner's* sole benefits. The costs of these tests will be the responsibility of the *Owner*.

Append to 4.12.10

If the *Contractor* performs *Work* for more than 12 hours per *Day*, or work shift, overtime costs incurred by the *Owner* to complete tests, inspections and payment measurements may be charged, at the sole discretion of the *Owner*, to the *Contractor*.

7.0 CHANGES

7.4 Optional Work

Append to 7.4.1

If *Optional Work* is performed prior to the *Contractor* achieving *Substantial Performance*, there shall be no adjustments to the *Contract Time*, unless the *Contractor* can demonstrate that the *Optional Work* will impact the critical path on the *Contractor's* schedule.

Apr. 2020

10.0 FORCE ACCOUNT

10.1 Force Account Costs

Append to 10.1.1 (1)

Costs for the *Contractor's Superintendent*, Project Managers, Health and Safety Personnel, and Office/Administration Staff are not eligible labour costs as those costs are considered incidental to the mark up owing for overhead on labour.

Delete 10.1.1
(2) (a) and
replace with

Contractor Owned or Bare Rented – at the non-operated hourly rates as set out in the *Approved Equipment Rental Rate Guide* based on the actual hours, in minimum increments of 0.5 hours, without any markup to cover all overhead costs and profits. If equipment is not listed in the *Approved Equipment Rental Rate Guide* then a rate determined by the *Contract Administrator* based on local equipment rental rates; or

11.0 CONCEALED OR UNKNOWN CONDITIONS

11.1 Definition

Delete 11.1.1
and replace
with

A "*Concealed or Unknown Condition*" is either *Archaeological Artifacts*, *Foreign Material*, *Hazardous Materials*, or *Municipal Utilities*, all as defined in GC and SGC paragraph 1.0, that:

Apr. 2020

- (1) occur at the *Place of Work*; and
- (2) materially affects the cost of, or the time required for, the performance of the *Work*; and
- (3) differs materially from conditions disclosed in the *Contract Documents*, and was not apparent in an examination of the *Place of the Work* or could not be reasonably inferred from geotechnical examinations and as-built utility records.

Add 11.1.2

The risk of, responsibility and liability for *Utilities*, not including *Municipal Utilities*, and subsurface soil conditions and groundwater conditions, known or unknown, rests solely with the *Contractor*. The *Contractor* acknowledges and agrees that it has not relied on the accuracy or completeness of any data or information provided by or on behalf the *Owner* in assessing these risks except those defined in SGC 11.1.1 hereof and the *Contract Price* for the *Work* includes for these risks.

Apr. 2020

11.4 Acknowledgment

Add 11.4.1

The *Contractor* acknowledges and agrees that it has not relied on the accuracy or completeness of any data or information provided by or on behalf of the *Owner* in assessing the risks of a *Concealed or Unknown Condition*.

	Add 11.4.2	The <i>Contractor</i> acknowledges and agrees that it has conducted its own independent investigation and has taken into account the risks of a <i>Concealed or Unknown Condition</i> .
11.5 Archaeological Artifacts	Add 11.5.1	Any <i>Archaeological Artifacts</i> discovered by the <i>Contractor</i> shall, as between the <i>Owner</i> and the <i>Contractor</i> , be deemed to be the absolute property of the <i>Owner</i> .
	Add 11.5.2	The <i>Contractor</i> shall immediately advise the <i>Contract Administrator</i> of the discovery by the <i>Contractor</i> of any <i>Archaeological Artifacts</i> and take all reasonable precautions to protect and preserve same.
12.0 HAZARD MATERIALS		
12.2 Discovery of Hazardous Materials	Delete 12.2.2 and replace with	If the <i>Contract Administrator</i> observes any materials at the <i>Place of the Work</i> that the <i>Contract Administrator</i> knows or suspects may be <i>Hazardous Materials</i> then the <i>Contract Administrator</i> shall immediately give written notice to the <i>Contractor</i> and the <i>Contractor</i> shall immediately stop the <i>Work</i> or portion of the <i>Work</i> as required by GC 12.2.1 (1)
12.4 Contract Adjustment for Hazardous Materials	Append to 12.4.2	However, the <i>Contractor</i> is not entitled to payment of any delay costs associated with suspected or confirmed <i>Hazardous Materials</i> .
13.0 DELAYS		
13.8 Direction to Stop or Delay	Delete 13.8.2 and replace with	During any such stoppage or delay, the <i>Contractor</i> shall be responsible to protect the <i>Work</i> . The <i>Contractor</i> shall not be entitled to an extension to schedule or claim for costs if the direction to stop or delay was due to work being performed that was inconsistent with the <i>Contract Documents</i> or as a result of a safety hazard as deemed by the <i>Contract Administrator</i> or <i>Owner</i> or <i>Work Safe BC</i> .

**13.9 Liquidated
Damages for Late
Completion**

Delete 13.9.1
and replace
with

If the *Contractor* fails to meet the *Milestone Date* for *Substantial Performance*, or any other specified *Milestone Date*, as set out in the Form of Tender paragraph 2.2, as may be adjusted pursuant to the provisions of the *Contract Documents*, then the *Owner* may deduct from any monies owing to the *Contractor* for the *Work*:

- (1) as a genuine pre-estimate for the *Owner's* increased costs for the Contract Administrator and their field representative caused by such delay an amount of \$1,500 per calendar day, or pro rata portion, for:
 - a. each day that the *Work*, or portion of *Work*, was completed after the specified *Milestone Date* for that applicable *Work*, or portion of *Work*; and
 - b. each day that actual *Substantial Performance* is achieved after the *Substantial Performance Milestone Date*; plus
- (2) all direct out of pocket costs, such as, but not limited to: the *Owner's* own staff costs; costs for safety, security, or equipment rental required; and costs for temporary surface restoration and increased temporary maintenance which may be reasonably incurred by the *Owner* as direct result of such delay; plus
- (3) any loss to the *Owner* of third-party funding which the *Owner* was to receive if the *Work*, or a particular portion thereof, was not completed before a *Milestone Date*.

If the monies owing to the *Contractor* are less than the total amount owing by the *Contractor* to the *Owner* under (1), (2) or (3) then any shortfall shall immediately, upon written notice from the *Owner*, and upon *Substantial Performance*, be due and owing by the *Contractor* to the *Owner*.

15.0 OWNER'S RIGHT ON CONTRACTOR'S DEFAULT

15.2 Notice of Default

Delete 15.2.1
and replace
with

On the occurrence of any one or more of the following events:

- (1) it is discovered that any representation or warranty made by the *Contractor* was false or materially misleading when made;
- (2) the *Contractor* fails to procure or maintain any bonds or required insurance coverage;
- (3) the *Contractor* fails to comply with the requirements or obligations of the Workers Compensation Act;
- (4) the *Contractor* fails to diligently proceed with and prosecute the Work;
- (5) the *Contractor* fails to comply with any requirements of the *Contract*.

the *Owner* may notify the *Contractor* in writing that the *Contractor* is in default of the *Contractor's* obligations and instruct the *Contractor* to correct the default in the 5 *Days* immediately following the receipt of such notice.

15.3 Termination

Append to
15.3.1

After receipt of a written notice of termination, and except as otherwise directed by the *Contract Administrator*, the *Contractor* shall:

- (1) stop *Work* under the *Contract* on the date and to the extent specified in the notice of termination;
- (2) place no further orders or subcontracts except as may be necessary for completion of such portion of the *Work* as is not terminated;
- (3) as directed by the *Contract Administrator*, terminate all orders and subcontracts to the extent that they relate to the performance of *Work* terminated by the notice of termination and/or assign, transfer and deliver to the *Owner* or to whom the *Owner* directs in the manner, at the times, and to the extent directed by the *Contract Administrator*, all of the right, title and interest of the *Contractor* under the subcontracts;

- (4) transfer title and deliver to the *Owner* in the manner, at the times and to the extent, if any, directed by the *Contract Administrator*, the fabricated or un-fabricated parts of *Work* in process, completed *Work* produced as part of, or acquired in connection with the performance of, the *Work* terminated by the notice of termination and in the *Contractor's* possession or reasonable control;
- (5) complete performance of such part of the *Work* as shall not have been terminated by notice of termination; and
- (6) mitigate the costs for which the *Owner* may be liable.

16.0 CONTRACTOR'S RISK ON OWNER'S DEFAULT

16.2 Work Stoppage

Delete
16.2.2 and
replace with

The *Owner* may, at its discretion, stop all or part of the *Work* in which event, subject to GC 16.4.1, the provisions of GC 13 (Delays) shall apply. If the *Work* stoppage required under this GC 16.2.2 continues for 60 calendar days, and provided the *Work* is not required or requested to accommodate seasonal work or to accommodate the relocation of third-party utilities, the *Contractor* may, by giving written notice to the *Owner*, terminate the *Contract*.

16.4 Termination

Delete
16.4.1 and
replace with

If the *Contractor* terminates the *Contract* under the conditions set out in GC 16.2.2., the *Owner* shall pay the *Contractor*:

- (1) for *Work* done under the *Contract*, pursuant to the terms of the *Contract*; plus
- (2) reimbursement of expenditures, such as products and materials, *Subcontractors* and equipment, which the *Contractor* incurred to the date of termination on account of the remaining *Work*.

The amounts recoverable by the *Contractor* pursuant to this GC 16.4.1 shall be the *Contractor's* sole remedy for any and all costs, damages and expenses resulting from the events giving rise to the termination by the *Contractor*. In no event shall the *Contractor* be entitled to claim or recover against the *Owner* any costs, damages or expenses, whether for breach of *Contract* by the *Owner* or pursuant to the *Contract*, for loss of anticipated profits, consequential damages, impact costs, loss of contribution to overhead or any amount, other than those amounts recoverable pursuant to GC 16.4.1.

17.0 DISPUTES

17.5 Referee

Delete
17.5.2 (2) and
replace with

(2) if the parties have not agreed upon a *Referee* within 3 *Days* the submission of names by one party or the other as provided by GC 17.5.2 (1), then the other party may request in writing the Master Municipal Construction Documents Association (The Association) to appoint the *Referee*. The Association will have the authority to appoint a *Referee* without further consultation with the parties and the parties shall accept the Associations appointment. If for any reason the Association fails to appoint a *Referee* within 5 *Days* of the written request then such failure shall be deemed to be an agreement between the parties to omit a review of that *Dispute* by a *Referee* and a party may at the end of the 5 *Days* request a settlement meeting and proceed with the remaining steps in the *Dispute* resolution process as described in this GC.

18.0 PAYMENT

18.5 Payment

Delete 18.5.1
and replace
with

The net amount shown for payment on a *Payment Certificate* shall be due and payable to the *Contractor* on or before the thirtieth (30th) calendar day from receipt of the *Payment Certificate* by the *Owner*.

20.0 LAWS, NOTICES, PERMITS, AND FEES

- 20.2 Permits** Add 20.2.3 Apply for and obtain all necessary permits from the City of Surrey for working within *Highway Right-of-Way*, and for obstructing traffic.
- 20.4 Fees** Add 20.4.1 The *Contractor* is responsible for paying all fees required to obtain permits from the City of Surrey.
- Add 20.4.2 The *Contractor* is responsible for displaying all permits at the *Place of Work*, and on all vehicles and equipment. If the *Contractor* receives tickets for traffic and bylaw infractions, these fees shall be paid directly to the City of Surrey and failure to pay such may result in a work stoppage or a permanent holdback in the amount due on the *Contractor's Payment Certificate*.

21.0 WORKERS COMPENSATION REGULATION

- 21.1 Evidence of Compliance** Append to 21.1.1 As a minimum, the evidence to be provided by the *Contractor* shall include the *Contractor's Workers' Compensation Board* registration number and a letter from the *Workers' Compensation Board* confirming that the *Contractor* is registered in good standing with the *Workers' Compensation Board* and that all assessments have been paid to the date thereof.
- Add 21.1.3 The *Contractor* agrees that it shall, at its own expense, procure and carry, or cause to be procured, carried and paid for, full *Workers' Compensation Board* coverage for itself and all workers, employees, servants and others engaged in or upon any *Work*.

**21.2 Contractor is
“Prime
Contractor”**

Delete 21.2.1
and replace
with

Commencing on the effective date of the *Notice to Proceed* and until such time as the *Contractor* has achieved *Total Performance*, as part of the Work the *Contractor* shall be the “*Prime Contractor*” as defined in the *Workers Compensation Act* and accordingly shall comply with all resulting requirements and obligations including coordination of the health and safety activities of all employees at the *Place of Work*, and complying with the obligations of a prime *Contractor* for a multi-employer workplace as prescribed by the applicable regulations. For certainty, except for that period during which the *Contractor* is the “*Prime Contractor*” pursuant to this Section 21.2.1, the *Owner* or appointed third party shall be the “*Prime Contractor*” for safety at the *Place of Work*.

Add 21.2.2

The *Contractor* agrees that it is the “*Prime Contractor*” for the *Work* as defined in the *Workers Compensation Act*, R.S.B.C. 2019, c. 1 as amended and will ensure compliance with the *Workers Compensation Act* and Regulations in respect of the workplace. Without limiting its responsibilities under the legislation, the *Contractor* will coordinate the activities of employers, workers and other persons at the workplace relating to occupational health and safety. The *Contractor* shall have a safety program acceptable to the *Workers' Compensation Board*, shall provide first aid services, and shall ensure that all *Workers' Compensation Board* safety rules and regulations are observed during performance of this Agreement, not only by the *Contractor*, but by all sub-*Contractors*, workers, material personnel and others engaged by the *Contractor* in the performance of this Agreement. The *Prime Contractor* shall appoint a qualified coordinator for the purpose of ensuring the coordination of health and safety activities for the workplace. Prior to commencement of Construction, the *Contractor* shall complete and file a “*Construction Notice of Project*” with the *Workers' Compensation Board* and shall provide a copy of the same to the *Owner* confirming that the *Contractor* shall be the *Prime Contractor* responsible for coordination of safety and health

under Part 3 of the Workers Compensation Act and Part 20 of the WCB Occupational Health & Safety Regulations

**21.3 Compliance with
Workers
Compensation
Requirements**

Add 21.3.3

The *Contractor* shall ensure compliance with and conform to all health and safety laws, by-laws or regulations of the Province of British Columbia, including any regulations requiring installation or adoption of safety devices or appliances.

Add 21.3.4

The *Contractor* shall fulfil all its duties, obligations and responsibilities in such a manner that it ensures the safety of the public and in accordance with the safety regulations of the Workers' Compensation Board and shall install signs and barriers as required to ensure the safety of the public and of its employees in the use of Highways and City of Surrey facilities.

Add 21.3.5

The *Contractor* agrees that the *Owner* has the unfettered right to set off the amount of the unpaid premiums and assessments for the Workers' Compensation Board coverage against any monies owing by the *Owner* to the *Contractor*. The *Owner* shall have the right to withhold payment under this *Contract* until the Workers' Compensation Board premiums, assessments or penalties in respect of the work done or service performed in fulfilling this *Contract* have been paid in full.

22.0 INDEMNIFICATION

22.1 *Contractor to Indemnify*

Delete 22.1.1 and replace with

Without limiting the generality of any other indemnities granted by the *Contractor* in the *Contract Documents*, the *Contractor* shall indemnify and hold harmless the *Owner*, its elected and appointed officials, employees and agents, and the Contract Administrator, their agents and employees, from and against all liabilities, actions, causes of action, claims, damages, expenses, costs, debts, demands or losses suffered or incurred by them or any of them, including consequential damages and damages to third parties, whether known or unknown, foreseeable or not, that arise out of, or are attributed to, any act or omission or alleged act or omission of the *Contractor*, the *Contractor's* agents, *Subcontractors*, Suppliers, corporations and employees engaged in performance of *Work* under this *Contract*.

24.0 INSURANCE

24.1 Required Insurance

Delete 24.1.1 (2) and replace with

(2) Commercial General Liability Insurance through an insurance underwriter licensed to conduct insurance business in the Province of British Columbia, covering bodily injury and property damage with a minimum occurrence and aggregate limit of \$5,000,000.00.

The policy will be endorsed to include the *Owner*, the *Contract Administrator* and all *Subcontractors* as additional insureds. Contractual liability coverage will be of sufficient scope to include the liability assumed by the *Contractor* under the terms of this *Contract* and the on-site creation and installation of any *Public Art* undertaken in conjunction with the *Work*.

The insurance shall include:

- (1) Premises and Operations
- (2) Broad Form Products and Completed Operations;
- (3) *Owner's* and *Contractor's* Protective Liability;
- (4) *Contractor's* Contingent Liability;
- (5) Blanket Contractual;

- (6) Contingent Employer's Liability;
- (7) Non-Owned Automobile;
- (8) Cross Liability/Severability of Interests;
- (9) Employees as Additional Insureds;
- (10) Personal Injury;
- (11) Broad Form Property Damage;
- (12) Sudden and Accident Pollution:
 - Minimum occurrence and aggregate limit shall be \$2,000,000 except where the *Work* is within 30 metres of a pipeline owned by Kinder Morgan Canada the minimum occurrence and aggregate limit shall be \$20,000,000.
- (13) Shoring, Blasting, Excavating, Underpinning, Demolition, Removal, Pile-driving and Caisson Work, Work Below Ground Surface, Tunnelling and Grading, as applicable;
- (14) Elevator and Hoist Liability;
- (15) Hook Liability, Riggers Liability
- (16) Operation of Attached Machinery;
- (17) Where the *Contractor* is providing Shop Drawings or other material sealed by a Professional Engineer the *Contractor*, or their Professional Engineer, shall provide a certificate of insurance for Professional Liability with a minimum occurrence and aggregate limit of \$1,000,000.

If a Wrap-up Commercial General Liability policy is not purchased by the *Contractor*, the *Contractor* shall ensure that all *Subcontractors* purchase and maintain during the term of the contract, Commercial General Liability insurance to the minimum levels specified in this agreement.

Any deductible shall be for the account of the *Contractor*. The policy will include coverage for flood and earthquake, and shall extend to cover any *Public Art* undertaken in conjunction with the *Work*, and property at any other location, while in storage, transit and during erection, installation and testing. Coverage shall extend to protect the interest of the *Owner*, and to the extent that the *Owner* has an insurable interest, the policy will have the *Owner* as first loss payee.

- Add 24.1.1 (5) The insurance shall include:
- (1) a Breach of Conditions clause, “Notwithstanding anything contained elsewhere in this policy, any breach of a condition of the policy, whether by commission or omission, by one of the parties hereby insured shall not prevent recovery by any other party or all parties hereby insured who are innocent of any such act or breach.”
 - (2) coverage of resultant damage from error in design that are carried out by the *Contractor*;
 - (3) coverage of resultant damage from faulty workmanship; and
 - (4) coverage of resultant damage from faulty materials.
- Add 24.1.1 (6) The *Contractor* shall provide a certificate of insurance in the form attached to the *Contract Documents*. In the event of conflicts between GC 24 and the certificate attached to the *Contract Documents*, the more stringent requirements shall apply.

27.0 PATENTS AND COPYRIGHTS

- 27.1 Patent and Copyright Compliance** Add 27.1.1 The *Contractor* shall pay all royalties, patents and license fees applicable to any portion of the *Work*. The *Contractor* is obligated to ensure that the *Work* as performed does not breach any copyright, patent or license agreement.

28.0 NON-RESIDENTS

- 28.1 Non-Residents** Add 28.1.1 If the *Contractor* is a non-resident of Canada, the *Contractor shall*:
- (1) obtain all necessary approvals, consents, permits, licenses, certificates, registrations and other authorizations required to comply with all applicable laws, regulations, by-laws or Codes in the performance of the *Work*;

- (2) obtain from the Retail Sales Tax Office, a certificate confirming that the *Contractor* has duly registered, and provide proof of same to the *Contract Administrator*, prior to commencement of the *Work*.

Add 28.1.2 The *Contractor* shall ensure that all *Subcontractors* who are non-resident in British Columbia have obtained all necessary approvals, consents, permits, licenses, certificates, registrations and other authorizations required to comply with all applicable laws, regulations, by-laws or Codes in the performance of the *Work*, and have registered with the Retail Sales Tax Office, has a Goods and Service Tax registration number, a provincial Retail Sales Tax registration number and a Workers Compensation Office registration number.

Add 28.1.3 The *Contractor* is responsible to ensure that all applicable taxes or remittances are made by itself and its *Subcontractors* and in relation to non-resident *Subcontractors*, any applicable retentions or withholdings are made.

Add 28.1.4 If the *Contractor* does not provide to the *Owner* a waiver of regulation letter, or satisfactory evidence to satisfy the conditions of GC 28 then the *Owner* may withhold and remit to the appropriate authority the greater of:

- (1) 15% of each payment due to the *Contractor*;
or
- (2) the amount required under applicable tax legislation.

END OF SECTION



Engineering Department

**Supplementary Master
Municipal Construction Documents**

SUPPLEMENTARY SPECIFICATIONS

April 2020

The City of Surrey Supplementary Master Municipal Construction Documents are supplemental to the **Master Municipal Construction Document – Platinum Edition (2009)** and take precedence over the MMCD General Conditions, Specifications, Standard Detail Drawings and their Amendments.

TABLE OF CONTENTS

	<u>PAGE</u>
MMCD SECTION 01 33 01	PROJECT RECORD DOCUMENTS..... 1
MMCD SECTION 01 34 00S	START-UP TESTING AND COMMISSIONING 3
MMCD SECTION 01 42 00	REFERENCED SPECIFICATIONS 7
MMCD SECTION 01 55 00	TRAFFIC CONTROL, VEHICLE ACCESS AND PARKING 8
MMCD SECTION 01 57 01	ENVIRONMENTAL PROTECTION 13
MMCD SECTION 01 58 01	PROJECT IDENTIFICATION 17
MMCD SECTION 01 62 01S	LIST OF APPROVED MATERIALS AND PRODUCTS..... 18
MMCD SECTION 03 30 20	CONCRETE WALKS, CURBS AND GUTTERS 30
MMCD SECTION 03 30 53	CAST-IN-PLACE CONCRETE 32
MMCD SECTION 26 05 34S	CONDUIT FOR COMMUNICATION NETWORK..... 33
MMCD SECTION 26 56 01	ROADWAY LIGHTING 36
MMCD SECTION 31 05 17	AGGREGATES & GRANULAR MATERIALS 38
MMCD SECTION 31 11 41	SHRUB AND TREE PRESERVATION 39
MMCD SECTION 31 15 60	DUST CONTROL..... 40
MMCD SECTION 31 22 01	SITE GRADING..... 41
MMCD SECTION 31 23 01	EXCAVATING, TRENCHING AND BACKFILLING 42
MMCD SECTION 31 24 13	ROADWAY EXCAVATION, EMBANKMENT AND COMPACTION 46
MMCD SECTION 32 01 11	PAVEMENT SURFACE CLEANING AND REMOVAL OF PAVEMENT MARKINGS 48
MMCD SECTION 32 01 16.7	COLD MILLING 49
MMCD SECTION 32 11 16.1	GRANULAR SUBBASE 51
MMCD SECTION 32 11 23	GRANULAR BASE 52
MMCD SECTION 32 12 16	HOT-MIX ASPHALT CONCRETE PAVING 53
MMCD SECTION 32 12 17	SUPERPAVE HOT-MIX ASPHALT CONCRETE PAVING 56
MMCD SECTION 32 14 01	UNIT PAVING 59
MMCD SECTION 32 17 23	PAINTED PAVEMENT MARKINGS 60
MMCD SECTION 32 31 13	CHAIN LINK FENCES AND GATES 61
MMCD SECTION 32 91 21	TOPSOIL AND FINISH GRADING 62
MMCD SECTION 32 92 23	SODDING..... 63
MMCD SECTION 32 93 01	PLANTING OF TREES, SHRUBS AND GROUND COVERS 64
MMCD SECTION 33 01 30.1	CCTV INSPECTION OF PIPELINES 65
MMCD SECTION 33 01 30.2	SEWER CLEANING 67
MMCD SECTION 33 11 01	WATERWORKS 68
MMCD SECTION 33 30 01	SANITARY SEWERS 74
MMCD SECTION 33 34 01	SEWAGE FORCE MAINS 81
MMCD SECTION 33 40 01	STORM SEWERS 84
MMCD SECTION 33 42 13	PIPE CULVERTS..... 86
MMCD SECTION 33 44 01	MANHOLES AND CATCH BASINS 87
MMCD SECTION 34 41 13	TRAFFIC SIGNALS 91

Apr. 2020

MMCD Section 01 33 01

Project Record Documents

1.0 GENERAL

Append to 1.0.1 Operation and Maintenance (O&M) manuals shall be prepared by the Contractor for all projects containing mechanical, electrical or instrumentation materials and equipment, such as but not limited to: pump stations; sewage force mains and siphons; district energy systems; flood boxes, control valves and gates; storm water detention and water quality facilities; reservoirs, pressure reducing stations, wells, flow meters and level meters.

O&M manuals shall address all related below-ground and building interior materials and equipment.

1.4 Format

Append to 1.4.2 Binders shall contain DVD's with all documents in PDF format.

Append to 1.4.3 Groupings should be based on MMS Division or Discipline (i.e. HVAC, electrical, instrumentation, etc.).

Append to 1.4.7 Drawings to be included in binders shall consist of Contract Drawings and Shop Drawings.

1.5 Contents, Each Volume

Append to 1.5.3 Part number and serial number shall be included in the list of information for each product.

Append to 1.5.5 The sequence of instructions shall include an Operational Narrative, to be written by the Contract Administrator, that identifies: design objectives and parameters (flows, pressures, velocities); operational and control philosophy, on-off set points, high and low level alarms, primary, duty and secondary control settings and relationship; and emergency power capacity and fuel capacity.

Append to 1.5.6 Manufacturer's calibration and testing results and certificates for range of parameters and equipment including flow, velocity, pressure, horsepower and air quality emissions.

Append to 1.5.7 Safety Requirements: list of all hazards and safe practices required, including electrical hazards, confined space areas, fall protection, system isolation, de-pressurising utilities, lockout procedures and required safety training programs.

- | | | | |
|------------|-------------------------------------|-----------------|---|
| | | Append to 1.5.8 | Parts Inventory: a checklist and tabular summary of all critical parts, and their average delivery times, and recommendation on which spare parts should be kept on hand. |
| 1.6 | Record Documents and Samples | Add 1.6.1.10 | Shop Drawings that require an Engineer's Seal are to be sealed by a Professional Engineer registered in the Province of British Columbia. |

END OF SECTION

MMCD Section 01 34 00S Start-up Testing and Commissioning

1.0 GENERAL

1.1 Overview .1

This section is applicable to all projects containing mechanical , electrical or instrumentation materials and equipment, such as but not limited to: pump stations; sewage force mains and siphons; district energy systems; flood boxes, control valves and gates; storm water detention and water quality facilities; reservoirs, pressure reducing stations and wells; flow and level meters.

The Contractor shall provide, test, commission, and turn over, to the City, a complete operating facility as described in the contract

1.2 Related Work .1

Project Record Documents – Section 01 33 01.

1.3 Scheduling of work .1

The startup testing and commissioning may need to be or be best scheduled at a time where suitable conditions are present to adequately test the equipment or facility, or at a time when it will disrupt the public or services to the residents the least. The Contractor shall schedule the testing and commissioning to suit these conditions and to cause the least disruption.

1.4 Commissioning Planning .1

The Contractor shall provide a plan and checklist indicating components and systems to be tested, detailed procedure and schedule for testing and commissioning to the Contract Administrator one month, or sooner, in advance of the commissioning. The checklist shall indicate the following:

1. components and systems to be tested or set
2. test, check or setting result
3. initials of person doing test, check or setting,
4. date and time.

The Contract Administrator and the City will review the plan and checklist and provide any comments they have to the Contractor within one week. The Contractor shall update the plan and checklist based on the Contract Administrator’s and City’s comments as needed.

The Contractor shall provide the final testing and commissioning plan and checklist to the Contract Administrator and the City two weeks in advance of the commissioning.

The testing and commissioning plan and checklist shall be followed during the testing and commissioning of the equipment.

The Contract Administrator may order any changes in testing plan, procedure, operation or schedule at any time before or during testing and commissioning to ensure correct commissioning.

1.8 Payment .1

Payment for all work performed under this Section will be incidental to payment for work described in other Sections unless shown otherwise in the Schedule of Quantities and Prices.

2.0 PRODUCTS

Not Used

3.0 EXECUTION

3.1 Personnel .1

The Contractor shall provide competent, experienced and trained personnel to supervise the installation, inspection, pre-testing, testing and commissioning of all components and systems installed under this contract. The cost of the personnel supplied by the Contractor, manufacturer and suppliers shall be included in the contract prices.

Operation of any part of the existing system shall be performed by the City.

Contract Administrator, City and Contractor will be present for the testing and commissioning

3.2 Pre-testing .1

The Contractor shall:

- .1 Pre-test all components and systems before start up testing and commissioning where possible, including assistance from the equipment manufacturer's representatives. This must be coordinated with the Contract Administrator and Owner.
- .2 Inspect all materials and components to ensure that the work is complete and that materials and components are in place and secure.

- .3 Ensure that all of the manufacturers and suppliers requirements and recommendations have been complied with.
- .4 Clean the facility and equipment.
- .5 Pre-test all lights, alarms, locks, and site safety equipment.
- .6 Pre-test components and systems by themselves and in combination with related components and systems to ensure they are operating properly and comply with specified requirements.
- .7 Pre-test all components over the entire range of operation specified including variations in flow, pressures, speeds and controls/levels.
- .8 Pre-test all malfunctions, alarms, safety devices, interlocks and annunciation by simulation of malfunctions as necessary.

Should tests, checks, inspections indicate defective components or work or performance in variance with specifications the Contractor shall correct the defect or performance.

3.3 Testing and Commissioning .1

- .1 In the presence of the Contract Administrator and the City, the Contractor and the manufacturer's representatives shall:
 - .1 test all individual components and systems individually and in combination with related components and systems to ensure they are operating properly and comply with specified requirements.
 - .2 test and demonstrate all components and systems over the entire range of operation specified including variations in flow, pressures, speeds and controls.
 - .3 demonstrate all malfunctions, alarms, safety devices, interlocks and annunciation by simulation of malfunctions as necessary.

- .2 Should tests, checks, inspections indicate defective components or work or performance in variance with specifications the Contractor shall correct the defect or performance.
- .3 All tests, checks, calibration, adjustments and settings shall be recorded by the Contractor. The record shall be included in the Operation and Maintenance manual.
- .4 Provide manufactures certifications as specified before acceptance of the work. The certificates shall be included in the Operation and Maintenance manual.
- .5 The Contractor must co-operate with the City during testing, start-up and commissioning and during work by the City to install the pertinent equipment for its SCADA system. The SCADA system back panel will be supplied by the City to the Contractor for installation by the Contractor.
- .6 Once the testing of components and systems is considered satisfactory by the Contract Administrator the Contractor shall then operate the entire system in the presence of the Contract Administrator and the City.
- .7 Upon achieving Substantial Performance and once the operation of the entire system is considered acceptable and operating successfully for at least 48 hours, or longer duration as directed by the Contract Administrator and City, the City will assume responsibility for the operation of the facility at a time acceptable to the City.
- .8 Contractor to completely refuel all generators and fuel storage tanks after testing and prior to transfer to the City.

END OF SECTION

MMCD Section 01 42 00

Referenced Specifications

1.0 GENERAL

1.2 Referenced Specifications

Append to
1.2.15.5

CAN / CSA-A23.5 no longer exists and has been combined into the CSA A3000 Referenced Specification, therefore all references to A23.5 should be changed to CSA A3000.

Add 1.2.15.15

CAN / CSA-A5 no longer exists and has been combined into the CSA A3000 Referenced Specification, therefore all references to A5 should be changed to CSA A3000.

Add 1.2.15.16

CAN / CSA-A8 no longer exists and has been combined into the CSA A3000 Referenced Specification, therefore all references to A8 should be changed to CSA A3000.

Add 1.2.9.46

ASTM D6927-06 Standard Test Method for Marshall Stability and Flow of Asphalt Mixtures.

END OF SECTION

MMCD Section 01 55 00

Traffic Control, Vehicle Access and Parking

1.0 GENERAL

Append to
1.0.1

This section includes requirements for permanent signage.

Add 1.0.6

The Contractor is required to apply for and secure City Road and Right-of-Way (CRRP) and Traffic Obstruction (TOP) permits to carry out the Work. Contractor shall comply with the terms and conditions stipulated in these traffic control permits.

Add 1.0.7

For *Work* on Local Roads, except for road closures, and locations where traffic impacts will extend back to intersections of Arterial Roads, TOPs are required from the City with reference to the BC Traffic Control Manual however a formal Traffic Management Plan (TMP) is not required for submission to the City, unless instructed otherwise.

Apr. 2020

Add 1.0.8

For work in intersections, on Collector Roads on Arterial Roads, and where road closures are being proposed, the Contractor shall solely prepare a TMP(s), submit it to the City for acceptance.

The TMP(s) shall include:

- .1 Name of the: Contractor; Traffic Control Person / Subcontractor, Owner; Contract Administrator; Contract; Contractor's Traffic Manager, and the related addresses and contact information.
- .2 Be prepared by a qualified Traffic Management Company or Subcontractor, and in accordance with the BC Traffic Control Manual for work on Roadways, as amended.
- .3 Be prepared using editable computer program, relatively to scale, and submitted in digital PDF 11x17 format.
- .4 Include an accurate road configuration, with road names, north arrow marker, speed limit, and proposed extents of the Work.

- .5 Indicate placement marker and distance of signs; sign images and sign number; delineators, cones, barricades, etc.; position of certified TCP's and traffic control equipment including FAB's and HLWD's
- .6 Include Dynamic Message Signs (DMS) and static Message Signs, as directed by the City, for each direction of each project and provide advance notice for full closures.
- .7 Identify the number of lanes to be obstructed, along with taper lengths and widths of lanes.
- .8 Identify the impact to: bus stops; Intersections, turning isles; sidewalks; bike lanes, etc. Include measures to facilitate and maintain access.
- .9 Consider project specific restrictions (work hours, movements, etc.) as outlined in the Contract Documents.
- .10 Stipulate that advance notice of construction signs to be installed at least 5 (five) working days before planned traffic diversion/start of work.
- .11 Include map of full detour routes (if applicable), including the above requirements along each route

In the event that excessive traffic delays or unsafe conditions result from implementation of the TMP, the City at its sole discretion may suspend the Work, without schedule extensions nor payment of costs, and the Contractor will be required to modify the TMP.

Contractor responsible to allow sufficient time for TCP review, possible modifications, and preparation of signage when preparing the project schedule. No claims for delays or time extensions will be considered due to failure to obtain an approved TMP.

When work is required outside the allowable working/construction hours (i.e. night work), the Contractor shall apply for exemptions to noise by-laws. The Contractor shall complete all application forms and pay required fees to the City for exemptions

- | | | | |
|------------|--------------------------------|------------|--|
| 1.3 | Temporary Parking Areas | Add 1.3.2 | <p>Where it is necessary to temporarily disrupt on-street parking for construction:</p> <ol style="list-style-type: none">.1 Distribute 72-hour advance notices to affected residents and businesses..2 Supply and erect temporary no-parking signs 72 hours in advance and at the same time as issuing notice to residents and businesses. Temporary no-parking signs shall state hours and dates of when no-parking is permitted, as well as name and phone number of the Contractor..3 Do not impound parked vehicles unless instructed to do so by the RCMP, or if authorized by the City's Parking Services in conjunction with the City's By-law Enforcement..4 Vehicles may be towed at Contractor's risk and expense to a nearby location. Inform registered owner as soon as possible where vehicle has been relocated. Do not charge vehicle recovery or towing fees to vehicle owner..5 Prior to use of pay station areas for construction or storage/laydown of equipment and materials, Contractor to get written authorization in advance from the City and pay/reimburse the City for use of pay station areas. |
| 1.4 | Traffic Control | Add 1.4.14 | <p>Where business driveways are being obstructed for more than one day the Contractor shall consult with businesses and post signage to direct business patrons to an alternate entrance.</p> |
| | | Add 1.4.15 | <p>Do not obstruct any travelled way longer than is absolutely necessary.</p> |
| | | Add 1.4.16 | <p>Unless expressly stated to in the Contract Documents, temporary road closures will not be permitted.</p> |
| | | Add 1.4.17 | <p>Where temporary traffic obstructions are permitted by the City, advise the Contract Administrator:</p> <ol style="list-style-type: none">.1 At least five (5) Days prior to the date of any desired closures, and |

- .2 At least 15 Days prior to the date of any desired full closure, so that the Owner may assess traffic control priorities, and advertise the closure. If there are conflicts, the Contractor will be advised of alternate periods during which he may complete the requested traffic control measure;

1.5 Payment

Delete 1.5.1 and replace with

Payment for all work performed under this Section will be on a Lump Sum basis unless noted otherwise in the Schedule of Quantities and Prices. Payment shall be 10% upon preparing TMP's, securing permits and erecting traffic control devices; 80% distributed in monthly Progress Payments for traffic control persons and related control devices; and 10% upon Substantial Performance.

Add 1.5.2

Payment for supply, installation and maintenance of Dynamic Message Signs, also known as Changeable Message Boards, to be on a per sign per calendar week basis, pro-rated based on *Work Days*, unless noted otherwise in the Schedule of Quantities and Prices. Payment shall be for the number of signs requested by the Owner in accordance with the TMP and related permits while the signs are active/in-use, as required by the *City*.

2.0 PRODUCTS

2.1 Temporary Road Markings and Signage

Add 2.1.1

The temporary traffic line shall be a 100mm x 300mm strip of prefabricated reflective yellow tape having an adhesive backing and shall be placed at 10 metre intervals along the center of pavement.

Add 2.1.2

The temporary stop bar shall be 2 - 100mm continuous strips of prefabricated reflective white tape having an adhesive backing and placed across the travel lanes at traffic control intersections.

Add 2.1.3

Notice of Construction signs to be 1200mm x 1200mm and have black printing on fluorescent orange background.

Add 2.1.4

Signs shall be reflectorized to a minimum 3M Engineering Grade Standard, and include the project and Contractor's name imprinted on the back.

Apr. 2020

3.0 EXECUTION

3.1 Temporary Road Markings and Signage

- Add 3.1.1 Temporary traffic lines and stop bars shall be placed immediately following laying of the asphalt pavement.
- Add 3.1.2 Remove the temporary markings when instructed by the Contract Administrator, immediately before placement of the permanent traffic road markings.
- Add 3.1.3 Signs that are not conforming to standards will be removed and replaced with suitable signs at Contractor's cost.
- Add 3.1.4 Obtain prior approval from the Contract Administrator on construction speed limit changes.
- Add 3.1.5 When the permanent signs are removed during construction, the Contractor shall keep and maintain temporary signs of equal quality in place at all times until permanent replacement signs are reinstated.

3.2 Permanent Signage

- Add 3.2.1 Prior to commencement of the Work, prepare and deliver a list of all signs, such as traffic control signs, school signs and playground signs. The City will supply sleeves for traffic sign posts. The Contractor shall arrange to pick up the sleeves from the City. The Contractor is responsible for installing the sleeves and coordinating with the City to install the permanent signage. Contractor shall give the City at least ten (10) days' notice before requesting the permanent signs be installed.

Sign sleeves for bus stops will be supplied by Coast Mountain Bus Company and Contractor to coordinate.

END OF SECTION

MMCD Section 01 57 01

Environmental Protection

1.0 GENERAL

Delete 1.0.2 and replace with All Work shall comply with GC 20.4 Environmental Laws, including the City's Erosion and Sediment Control (ESC) By-law 2006 No. 16138, and any updates thereto.

Append to 1.0.4 Work in the vicinity of watercourses is subject to restrictions imposed by Federal, Provincial and Municipal Agencies.

1.2 Temporary Erosion and Sediment Controls

Delete 1.2.2.2 and replace with Do not operate construction equipment in watercourses.

1.4 Environmental Protection

Add 1.4.2.5 To avoid undue impact to nesting birds, vegetation will not be removed or altered during the sensitive breeding period which is generally between March 15 and August 15. If land clearing is necessary within this window, land clearing will proceed only after the Contractor's Qualified Environmental Professional (QEP) has completed an onsite survey to confirm no impact to nests.

If bird nests are found in areas requiring vegetation removal, appropriate buffer zones will be implemented to reduce sensory disturbance until chicks have fledged.

1.6 Payment

Delete 1.6.1 and replace with Payment for all work performed under this Section will be on a Lump Sum basis unless noted otherwise in the Schedule of Quantities and Prices. Payment shall be 15% upon installing ESC measures; 80% distributed in monthly Progress Payments for maintenance and monitoring related work; and 5% upon Total Performance.

Apr. 2020

2.0 PRODUCTS

2.1 Contractor Machinery and Equipment

Add 2.1.1 All diesel engine construction equipment and machinery that is 25 horsepower (19 kW) or greater, whether owned or operated by the Contractor or a Subcontractor, shall be registered and in compliance with Metro Vancouver's Non-Road Diesel Engine Emissions Regulation Bylaw No 1161, and any updates thereto. Certificates / labels of registration shall be clearly visible on the side or rear of the equipment and machinery.

- Add 2.1.2 All construction equipment and machinery and generators shall be fitted with standard noise suppression devices. If noise abatement is deemed necessary by the Contract Administrator, mitigation measures, such as time sensitive restrictions or the use of smaller, less disturbing equipment, may be implemented upon the Contractor.
- Add 2.1.3 Prior to construction, the Contractor will verify that equipment and machinery used is in good working condition and free of fuel and lubricant leaks. Necessary maintenance oils/lubricants will be stored in a separate, contained lay-down area, and all maintenance activities will be conducted at least 30 metres away from any watercourse.
- 2.2 Implementation** Add 2.2.1 A fuel spill emergency response kit is to be kept at the place of Work at all times, including at least one for each site/location. The kit should include: material data sheet for hazardous materials being used on site; emergency contact list; absorbent pads; straw bale and poly covers; and floating containment boom for locations adjacent to watercourses.
- 3.0 EXECUTION**
- 3.1 Implementation** Add 3.1.1 The Contractor is responsible for supply, installation, and maintenance of the necessary ESC measures through the entire duration of the Contract, including the clearing and construction stages and through the Maintenance Period, unless noted otherwise in the Contract Documents.
- Add 3.1.2 Storm water discharge from the project site must comply with the City's ESC By-law 2006 No. 16138, and any updates thereto.
- Add 3.1.3 The Contractor shall use appropriate means to protect the water quality of all ditches, watercourses and drainage infrastructure.
- Add 3.1.4 All ESC measures shall be established in place, and inspected by the Contract Administrator, prior to commencement of any clearing, excavation/stripping and/or placement of fill material.

Exclusion zones around watercourses and wetlands shall be flagged to prevent disturbance of vegetated riparian areas by construction machinery, equipment and personnel.

Filter fabric, particularly at catch basins and drainage inlets, and silt fences shall be kept clean during construction to ensure adequate drainage is maintained.

- 3.2 Flow Diversion**
- Add 3.2.1 The Contractor is responsible for management, control and flow diversion, including bypass pumping and water quality treatment, if required, of water from the site, where water includes but not limited to: excavation and trench dewatering, groundwater, surface runoff, sewer and ditch flows, and watercourse flows.
 - Add 3.2.2 Flow diversion is to be implemented in accordance with the City's ESC By-Law, and other Municipal and Agency bylaws and regulations, including discharge quality requirements. If discharge requires third-party permits (i.e. Metro Vancouver, FLNRO, DFO, etc.) the Contractor is required to apply and secure these permits, including the associated costs, as part of their Work.
 - Add 3.2.3 If requested by the Contract Administrator, the Contractor shall prepare and submit a Flow Diversion Plan to the Contract Administrator for review prior to works being completed. The Flow Diversion plan should include: map of the site area complete with excavation and trench limits, location of water sources, proposed pumps/intake piping, proposed flow isolation location and proposed discharge locations; construction methodology; pump, piping and well pointing sizes, including flow rates expected; and ESC measures required for flows. Preparing this plan is considered incident to all other work described in this Section.
 - Add 3.2.4 If the Work involves construction in and around a watercourse, the Contractor is responsible for site isolation of watercourse flows and fish salvage prior to any dewatering and construction. Related flow diversion during construction shall be completed using gravity piping or pumps equipped with fish screens, in accordance with FLNRO and DFO Guidelines.

- Add 3.2.5 Sediment laden water shall be properly handled by the Contractor and as a minimum be discharged to a flat, vegetated area or an impervious container, before being further controlled and discharged off site.
- 3.3 Adjustment and Maintenance**
- Add 3.3.1 The Contractor is responsible for anticipating ESC concerns and adjusting their work plan to mitigate potential risks to ensure all Work is completed in accordance with the Environmental Laws.
- Add 3.3.2 For temporary flow diversion pumping systems, which operate on a 24-hour basis, Contractor is responsible for operation and maintenance which includes competent staff to operate and maintain the equipment including re-fuelling the pumps and generators at all times, including night-time and weekends, and have security personal present to ensure equipment is fully functional.
- Add 3.3.3 Deficiencies identified by the Contract Administrator, their site representative and through regular ESC monitoring reports shall be corrected by the Contractor within a reasonable time frame, and no longer than 48 hours. If additional ESC measures are required to correct the deficiencies then these measures are deemed incidental to other work described in this Section and should the deficiencies not be completed within the set timeframe then the Owner reserves the right to have the works corrected and payment will be deducted, at cost plus 10%, from the Contractor's Progress Certificate with maintenance of the corrected measures to be the Contractor's responsibility.
- Add 3.3.3 Where sediment is observed to have been tracked onto a travelled area, as a result of the Contractor's Work, then the Contractor must perform sufficient street cleaning within four (4) hours of notification.
- Add 3.3.4 Maintenance and revisions to ESC measures are considered incidental to work described herein this Section.

END OF SECTION

MMCD Section 01 58 01

Project Identification

1.0 GENERAL

**1.2 Temporary
Project Signage**

Delete 1.2.1.1
and replace
with

1. One week prior to construction, the Contractor shall install information signs.
2. The Contractor shall maintain the signs for the duration of the contract.
3. The Contractor shall remove the signs after completion of construction.

Delete 1.2.1.2
and replace
with

The City will provide project notification signage and the Contractor shall delivery the signs to site, supply and install the framing, and erect the signage.

Append to
1.2.2.1

Contractor to deliver to businesses and residents copies of letter, provided by the Owner, advising these persons of intended construction activities. The Contractor shall deliver these letters no sooner than ten (10) Days and no later than five (5) Days before the start of construction in the affected area.

END OF SECTION

MMCD Section 01 62 01S List of Approved Materials and Products

This Section identifies the City of Surrey’s List of Approved Products and Materials, and applicable restrictions or specifications, which are to be read in conjunction with, and superseding, products specified within the MMCD Master Specifications. Alternates to the products in this Section require the written approval from the City of Surrey.

MMCD Section	Product	Approved Material / Type	Approved Product/Manufacturer	Restrictions/Additional Specifications
26 56 01	ROADWAY LIGHTING			
	Wire Conductor	Aluminium	<ul style="list-style-type: none"> Alcan Aluminium Nual SouthwireSimpull Prysmian Cable Northern Cable 	Copper conductor is acceptable from handhole to fixture in streetlight pole.
	Luminaires	LED Luminaires	<ul style="list-style-type: none"> LED Roadway lighting NXT series Fixture American Electric AutoBahn fixture 	<p>LED Roadway Lighting NXT series fixture, NXT-XX-X-7-2ES-X-XX-3-UL-S-2H with adjustable selectable driver. All X's are attributes to be determined by the lighting Consultant to meet City standards for that area.</p> <p>City may permit American Electric AutoBahn fixture Model No. ATB2-80BLEDEXX-XXX-R2-XX-P7.</p>
33 11 01	WATERWORKS			
2.1.4	Joint Protection		<ul style="list-style-type: none"> Trenton Tec Tape Denso Petrolatum Tape 	Apply joint protection as per Fraser Health requirement.
2.2.1	Ductile Iron Pipe	Ductile Iron, zinc-coated	<ul style="list-style-type: none"> Canada Pipe US Pipe Kubota 	AWWA C 151, Pressure Class 350. Nitrile gasket required when hydrocarbons encountered in soil.
2.2.2	PVC Pressure Pipe	<ul style="list-style-type: none"> PVC C900 PVCO C909 	<ul style="list-style-type: none"> Ipex NAPCO Royal 	<p>Permitted for 150mm – 300mm diameter. Shall be pigmented blue, and shall be bell thickened to ASTM D3139 Clause 6.2.</p> <p>Not permitted on Arterial Roads, nor are they permitted in areas subject to soil liquefaction in seismic events.</p> <p>Nitrile gasket required when hydrocarbons encountered in soil.</p>

Apr. 2020

Apr. 2020

Apr. 2020

MMCD Section	Product	Approved Material / Type	Approved Product/Manufacturer	Restrictions/Additional Specifications
2.2.3	High Density Polyethylene Pipe	HDPE DR 9	<ul style="list-style-type: none"> KWH Sclairpipe WL Plastics High Performance 	HDPE to AWWA C-906 pipe is permitted for water supply to Agricultural Lands only, and if diameter is 150mm or smaller.
2.2.4	Fittings	<ul style="list-style-type: none"> Ductile Iron Compact Ductile Iron 	<ul style="list-style-type: none"> Terminal City IW Sigma Products Star (C153) OB Waterworks 	Cast Iron fittings are not acceptable
		PVC C 907 Injection moulded 100mm – 300mm Diameter	<ul style="list-style-type: none"> IPEX NAPCO Royal 	PVC fittings for mainline water mains shall require restrainers to MMCD that do not de-rate the pressure rating of the pipe material.
		PVC C900 Fabricated 150mm – 300mm Diameter	<ul style="list-style-type: none"> IPEX NAPCO Royal Galaxy Plastic Pro-line Fittings 	High Deflection coupling by Certain Tee. PVC DR18, C800, Class 150, 5° bend fitting is acceptable.
		Bolts, Nuts and Tie Rods		Type 304 Grade A stainless steel required for all hardware.
	Couplings and Flange Coupling Adapters	Plain End	<ul style="list-style-type: none"> Dresser 38 or 62 Robar Smith-Blair Romac EBAA 3800 Ford Mueller 	Type 304 Grade A stainless steel required for all hardware
		Restrained Flange Adaptors	<ul style="list-style-type: none"> Romac RFCA Uniflange RFAD EBAA 2100 	Type 304 Grade A stainless steel required for all hardware
		Repair Clamps	<ul style="list-style-type: none"> Robar Romac Mueller Canpac 	Couplers shall have appropriate adaptor gaskets to suit OD of pipe material(s) being coupled.
	Joint Restraint Pipe System (seismic and landslide area)	Earthquake Resistant Ductile Iron Mains, or welded steel	<ul style="list-style-type: none"> TR-Xtreme GENEX/NS Welded Steel 	Other equivalent joint restraint mechanism or pipe material may be approved by the <i>Engineer</i>
	Joint Restraint Pipe Systems (non-seismic and landslide area)	Ductile Iron Mains, or welded steel	<ul style="list-style-type: none"> UniFlange Series 1400 EBBA Iron TR Flex Sigma Products Welded Steel 	Joint restraints shall have pressure rating equal to the mainline pipe. Type 304 Grade A stainless steel required for all hardware

Apr. 2020

Apr. 2020

MMCD Section	Product	Approved Material / Type	Approved Product/Manufacturer	Restrictions/Additional Specifications
		PVC / PVCO Mains	<ul style="list-style-type: none"> EBA Series 1900 Uniflange Series 1309, 1399, 1500 JCM Series 610 	Restrains for PVC/PVCO shall be approved by pipe manufacturer. Type 304 Grade A stainless steel required for all hardware
2.3.1	Gate Valves	50mm – 250mm Resilient-seated	<ul style="list-style-type: none"> Mueller Clow AVK Terminal City 	All valves shall have epoxy coated ductile iron body to AWWA C 509.
		300mm Resilient-seated	<ul style="list-style-type: none"> Mueller AVK Terminal City 	Ductile iron body to AWWA C 515. Valves >=300mm shall have brass or stainless steel stems.
2.3.3	Butterfly Valves	General		Not permitted unless approved by Engineer
2.3.4	Blow-off Valves	General		<p>Permanent blow-offs shall be as per Standard Drawing.</p> <p>Testing and Temporary blow-offs shall be to MMCD Drawing W8 complete with 50mm gate valve.</p> <p>Temporary valves for testing and flushing shall not be left exposed above grade.</p>
2.3.5	Air Valve		<ul style="list-style-type: none"> Apco Val-Matic Crispin 	
2.3.6	Water Valve Boxes		<ul style="list-style-type: none"> Terminal City Dobney Westview Trojan 	<p>Nelson Box will not be allowed.</p> <p>Circular Cast Iron (MR6 Style), 300mm length</p>
2.3.7	Service Valve Boxes	Curb Stop Box	<ul style="list-style-type: none"> Clow Dobney D-10 Muller A-726 Muller A-728 Trojan 	<p>150mm riser pipe with cast iron box (MR6 style).</p> <p>If in driveway, concrete meter box c/w metal lid.</p>
2.5.1	Water Service Connections	Pipe Material	Polyethylene	AWWA C-901 c/w #10 tracer wire shall be attached to all services
2.5.3	Service Saddles	Saddles for Ductile Iron Pipe	<ul style="list-style-type: none"> Robar Romac Smith Blair Mueller 	

Apr. 2020

Apr. 2020

MMCD Section	Product	Approved Material / Type	Approved Product/Manufacturer	Restrictions/Additional Specifications
		Saddles for PVC Pipe	<ul style="list-style-type: none"> • Canpac • Mueller • Robar • Romac • Smith Blair 	Saddles required for service installation on all PVC mains.
2.6	Hydrants		<ul style="list-style-type: none"> • Terminal City C71P • Canada Valve "Century" • Clow M93 Brigadier • AVK 2780 	<p>Ductile iron boot shall be installed.</p> <p>Refer to SS for Paint Colours and requirements</p>
2.7	Underground Service Line Valves and Fittings	Corporation Stop	<ul style="list-style-type: none"> • Cambridge • Ford • Mueller 	<p>Shall be full-port ball valve up to 38mm only.</p> <p>Use mainline ball valve for sizes 50mm and larger.</p>
		Curb Stop	<ul style="list-style-type: none"> • Cambridge • Ford • Mueller 	<p>Shall be full-port ball valve to 38mm with 90° turn stop.</p> <p>Use gate and check valve, near property line, for sizes 50mm and larger</p>
2.10	Casing Spacers		<ul style="list-style-type: none"> • Uniflange • Calpico • Raci 	Shall be fabricated cast iron or high density polyethylene insulating spacers designed to centre main in the carrier pipe.
33 30 01	SANITARY SEWERS			
2.1	Concrete Pipe	Non-reinforced and Reinforced Concrete	<ul style="list-style-type: none"> • Langley Concrete • Ocean Pipe 	<p>Manufacturers to be PPP or Q-Cast Certified</p> <p>Concrete sewers 200mm to 750mm requires prior approval from the Engineer. Sewers 900mm in diameter and larger shall have factory PVC/HDPE interior liner (T-Lok or Agru)</p>
2.2	Plastic Pipe, Mainline Smooth Profile	PVC SDR 35	<ul style="list-style-type: none"> • IPEX • NAPCO Royal • JM Eagle • Northern 	<p>Maximum diameter of 750mm</p> <p>Recycled PVC (EnviroTite SDR) is not permitted.</p> <p>No repairs from inside pipe.</p>

MMCD Section	Product	Approved Material / Type	Approved Product/Manufacturer	Restrictions/Additional Specifications
2.2 (cont'd)	High Density Polyethylene Pipe	HDPE smooth wall pipe with fusion welded joints	<ul style="list-style-type: none"> • KWH Sclairpipe • WL Plastics • High Performance 	<p>Only to be used at location approved by the City</p> <p>Shall be DR 21 or thicker</p>
2.3	Service Connections	PVC-SDR 28	<ul style="list-style-type: none"> • IPEX • NAPCO Royal • JM Eagle • Northern 	Minimum size shall be 100mm.
	Tees and Wyes	PVC-SDR 28	<ul style="list-style-type: none"> • IPEX • NAPCO Royal • JM Eagle • Northern 	Manufactured wye fitting shall be used for all connections on new mains.
		Insertable Tee	<ul style="list-style-type: none"> • Inserta Tee 	Insertable tee only permitted for connections to PVC and Concrete mains which are 200mm mains or larger. Connections to 150mm diameter mains, AC and VC mains, require manufactured wye.
		Saddle	<ul style="list-style-type: none"> • Robar 3506 • Romac CB 	<p>Applicable for connections to AC and Vitrified Clay mainlines.</p> <p>Stainless steel straps required.</p>
	Inspection Chamber	Inspection Chamber	<ul style="list-style-type: none"> • Pro-Line • NAPCO Royal • Galaxy Plastics 	IC to have locking lid c/w gasket
		MR Style Concrete Pull Box	<ul style="list-style-type: none"> • TR 10C • Dobney MR 10-18B • TC 10C 	Shall be used in all travelled areas. Cast iron lid permanently marked "Sanitary" OR "Storm", as required.
		Inspection Chamber Back-flow Check Valve	<ul style="list-style-type: none"> • Pro-line Fittings • NAPCO Royal • Galaxy Plastics 	Comply with CSA/CAN3 B70-M86.

Apr. 2020

Apr. 2020

MMCD Section	Product	Approved Material / Type	Approved Product/Manufacturer	Restrictions/Additional Specifications
33 34 01	SEWAGE FORCE MAINS			
2.2.1	Ductile Iron Pipe	General		Not permitted for sewage forcemains
2.2.2	PVC Pressure Pipe	<ul style="list-style-type: none"> PVC C900 PVCO C909 	<ul style="list-style-type: none"> Ipex NAPCO Royal 	<p>Permitted for 150mm – 300mm diameter, DR18 or thicker. Shall be pigmented blue, and shall be bell thickened to ASTM D3139 Clause 6.2.</p> <p>Not permitted on Arterial Roads, nor are they permitted in areas subject to soil liquefaction in seismic events.</p>
2.2.4	High Density Polyethylene Pipe	HDPE DR 17 (or thicker)	<ul style="list-style-type: none"> KWH Sclairpipe WL Plastics High Performance 	HDPE comply with AWWA C906 for pipe 100mm diameter and larger. Outside diameter (OD) to iron pipe size (IPS) dimensions.
2.2.5	Fittings:	Saddle	<ul style="list-style-type: none"> Friatec VA Corix Flo-Control (75-150mm) 	Electrofusion Saddle Service for HDPE
		Bolts, Nuts and Tie Rods		Type 304 Grade A stainless steel required for all hardware.
2.2.8	Low-pressure Sewage Force mains	HDPE DR 13.5 (or thicker)	<ul style="list-style-type: none"> KWH Sclairpipe WL Plastics High Performance 	HDPE comply with AWWA C901 for pipes 75mm diameter and smaller and AWWA C906 for pipe 100mm diameter and larger. Outside diameter (OD) to iron pipe size (IPS) dimensions.
		<ul style="list-style-type: none"> PVC C900 PVCO C909 	<ul style="list-style-type: none"> Ipex NAPCO Royal 	<p>Permitted for 150mm – 300mm diameter, DR18 or thicker. Shall be pigmented blue, and shall be bell thickened to ASTM D3139 Clause 6.2.</p> <p>Not permitted on Arterial Roads, nor in areas subject to soil liquefaction in seismic events.</p>

MMCD Section	Product	Approved Material / Type	Approved Product/Manufacturer	Restrictions/Additional Specifications
2.3.2	Gate Valves	50mm – 250mm Resilient-seated	<ul style="list-style-type: none"> • Mueller • Clow • AVK 	All valves shall have epoxy coated ductile iron body to AWWA C 509.
		>= 300mm Resilient-seated	<ul style="list-style-type: none"> • Mueller • AVK 	Ductile iron body to AWWA C 515. Valves >300mm shall have brass or stainless steel stems.
2.3.4	Air Valves		<ul style="list-style-type: none"> • Apco • ARI • Val-Matic 	25mm valves to be brass
2.3.6	Plug Valves		<ul style="list-style-type: none"> • APCO series 500 resilient-seated • Milliken Millcentric • Valmatic Eccentric 	All Plug Valves to be Full Port. Refer to SS Section 33 34 01, 2.6
2.3.7	Ball Valves		<ul style="list-style-type: none"> • Unifid Alloys 	All Ball Valves to be Full Port. 50mm and smaller to be brass, larger to be stainless steel and flanged.
2.3.8	Check Valves	Ball Check – Cast/Ductile Iron	<ul style="list-style-type: none"> • Danfoss 408/408FB 	Plastic check valves not permitted.
2.5	Low Pressure Sewage Pumps	Grinder Pumps	<ul style="list-style-type: none"> • ABS • Barnes • Environment One • Hydromatic • ITT Flytt / Xylem • Myers • Zoeller 	Refer to Design Criteria Manual for more specifications.
33 40 01	STORM SEWERS			
2.1	Concrete Pipe	Non-reinforced and Reinforced Concrete	<ul style="list-style-type: none"> • Langley Concrete • Ocean Pipe 	Manufacturers to be PPP or Q-Cast Certified Not permitted in Lowland areas (below 7.0m elev.)
2.2	PVC Pipe, Mainline Smooth Wall	PVC SDR 35	<ul style="list-style-type: none"> • IPEX • NAPCO Royal • JM Eagle • Northern 	Maximum diameter of 750mm Recycled PVC (EnviroTite SDR) not permitted. No repairs from inside pipe.

MMCD Section	Product	Approved Material / Type	Approved Product/Manufacturer	Restrictions/Additional Specifications
2.3	PVC Pipe, Mainline Profile		<ul style="list-style-type: none"> IPEX NAPCO Royal (Korflo) 	<p>Only permitted in Lowland areas (below 7.0m elev.)</p> <p>Only permitted up to 675mm in diameter. Spiral ribbed pipe is not permitted.</p> <p>IPEX Ultra-Rib not permitted.</p> <p>No repairs from inside pipe.</p>
2.4	HDPE Pipe, Mainline Open Profile	HDPE smooth wall pipe with fusion welded joints	<ul style="list-style-type: none"> KWH Sclairpipe WL Plastics High Performance 	<p>Only permitted in Lowland areas (below 7.0m elev.) unless approved otherwise by the City</p> <p>Shall be DR 21 or thicker</p>
2.5	Spiral Rib Steel Pipe		<ul style="list-style-type: none"> Not permitted 	Steel and CSP pipe is not permitted for storm sewers.
2.6	Service Connections	PVC-SDR 28	<ul style="list-style-type: none"> IPEX NAPCO Royal JM Eagle Northern 	Minimum size shall be 150mm.
	Tees and Wyes	PVC-SDR 28	<ul style="list-style-type: none"> IPEX NAPCO Royal JM Eagle Northern 	Manufactured wye fitting shall be used for all connections on new mains.
		Insertable Tee	<ul style="list-style-type: none"> Inserta Tee 	Insertable tee only permitted for connections to PVC and Concrete mains which are 200mm mains or larger. Connections to 150mm diameter mains, AC and VC mains, require manufactured wye.
		Saddle	<ul style="list-style-type: none"> Robar 3506 Romac CB 	<p>Applicable for connections to AC and Vitrified Clay mainlines.</p> <p>Stainless steel straps required.</p>

Apr. 2020

MMCD Section	Product	Approved Material / Type	Approved Product/Manufacturer	Restrictions/Additional Specifications
	Inspection Chamber	Inspection Chamber	<ul style="list-style-type: none"> Pro-Line NAPCO Royal Galaxy Plastics 	IC to have locking lid c/w gasket
		MR Style Concrete Pull Box	<ul style="list-style-type: none"> TR 10C Dobney MR 10-18B TC 10C 	Shall be used in all travelled areas. Cast iron lid permanently marked "Sanitary" OR "Storm", as required.
		Inspection Chamber Back-flow Check Valve	<ul style="list-style-type: none"> Pro-line NAPCO Royal Galaxy Plastics 	Comply with CSA/CAN3 B70-M86.
2.11	Polypropylene Pipe, Mainline Open Profile		<ul style="list-style-type: none"> ADS Sanitite HP 	<p>Only permitted in Lowland areas (below 5.0m elev.)</p> <p>Service connections on new Open Profile HDPE / Polypropylene mains shall be injection moulded PVC manufactured wyes for mains < 300mm.</p>
33 42 13	PIPE CULVERTS			
2.1	Corrugated Steel Pipe		<ul style="list-style-type: none"> Armtec Canada Culvert Atlantic Industries 	<p>Only permitted in Lowland areas (below 5.0m elev.)</p> <p>Shall be Aluminized II coating.</p> <p>Requires prior approval from the Engineer.</p>
2.2	Concrete Pipe	Non-Reinforced and Reinforced Concrete	<ul style="list-style-type: none"> Langley Concrete Ocean Pipe 	<p>Not permitted in Lowland areas (below 5.0m elev.)</p> <p>Manufacturers to be PPP or Q-Cast Certified.</p>
2.3	PVC Pipe, Mainline Smooth Wall	PVC-SDR 35	<ul style="list-style-type: none"> IPEX NAPCO Royal 	
2.4	PVC Pipe Profile, Mainline		<ul style="list-style-type: none"> IPEX NAPCO Royal (Korflow) 	<p>Only permitted in Lowland areas (below 5.0m elev.)</p> <p>Only permitted up to 675mm in diameter. Spiral ribbed pipe is not permitted.</p> <p>IPEX Ultra-Rib not permitted.</p>

Apr. 2020

Apr. 2020

Apr. 2020

Apr. 2020

Apr. 2020

MMCD Section	Product	Approved Material / Type	Approved Product/Manufacturer	Restrictions/Additional Specifications
2.5	HDPE Plastic Pipe, Open Profile		<ul style="list-style-type: none"> • Boss 2000 • ADS N12 	<p>Only permitted in Lowland areas (below 7.0m elev.)</p> <p>Certified to CSA B182.8-02</p> <p>Requires prior approval from the Engineer.</p>
2.9	Polypropylene Open Profile		<ul style="list-style-type: none"> • ADS Sanitite HP 	<p>Only permitted in Lowland areas (below 5.0m elev.) Refer to SS Section 33 42 13</p>
33 44 01	MANHOLES AND CATCH BASINS			
2.1	Precast Manhole sections	Manhole Base and Riser	<ul style="list-style-type: none"> • Diamond Precast • Langley Concrete • Ocean Pipe 	Manufacturers to have CSA, PPP or Q-Cast Third-Party Certification
2.1.7	Manhole Frames and Covers	Type 1 and 2 Height Adjustable Cast Iron Style		<p>Refer to Supplementary Specification Section 33 44 01</p> <p>ASTM A48-03, Class 35B Gray cast iron; or ASTM A536 Grade 65/45/12 ductile iron</p>
		Type 1 and 2 Height Adjustable	<ul style="list-style-type: none"> • East Jordan IW 00302201 Frame • East Jordan IW 00302201A01 Low Profile Frame <ul style="list-style-type: none"> ○ 00302220 Storm Cover ○ 00302228 Sanitary Sewer Cover ○ 00302227 Water Cover • Dobney C-44A Frame and Ring with C724 Style cover 	
		Low-profile Frame and Covers		Use of 100mm low profile frames and covers to be approved by the City.

Apr. 2020

Apr. 2020

MMCD Section	Product	Approved Material / Type	Approved Product/Manufacturer	Restrictions/Additional Specifications
2.1.13	Catch Basin and related castings	CB Frame	<ul style="list-style-type: none"> Dobney Westview Sales 	<p>Refer to Standard Drawings for required lettering on Manhole Covers for sanitary and storm sewers, including in fish habitat areas.</p> <p>Shall be compatible and interchangeable with existing City castings.</p>
		CB Grate	<ul style="list-style-type: none"> Dobney Westview Sales 	Refer to Standard Drawings for required lettering on CB Grates, including in fish habitat areas.
		Lawn Basin Grate	<ul style="list-style-type: none"> Dobney Westview Sales 	
2.1.16	Tapered Adjusting Rings	<ul style="list-style-type: none"> Concrete Ductile Iron EPP HDPE 	<ul style="list-style-type: none"> Ipex Dobney ARPRO 	
2.24	Sealant	Sealant to be ASTM D 1850	<ul style="list-style-type: none"> X-Seal from SealGuard Inc. 	
33 41 13	TRAFFIC SIGNALS			
2.5	Concrete Junction Boxes		<ul style="list-style-type: none"> Armtec 	Labelled "ELEC"
2.6	Poles and Anchor Bolts	Poles, Arms, Service Base	<ul style="list-style-type: none"> Nova Pole West Coast Engineering 	M.O.T.I./MMCD Galvanized and powder coated
2.7	Conductors and Cables	Pre-Emption Cable	GTT	Model 138
		Radio Cable	Cat 6 Ethernet cable	Outdoor rated
2.11	Service Panels	Service Panel	<ul style="list-style-type: none"> Westcoast Electric Valid Manufacturing 	Stainless Steel or Powder Coated Aluminum – See Std Drawings
2.16.	Traffic and Pedestrian Signals	Signal Heads	<ul style="list-style-type: none"> Econolite Eagle 	M.O.T.I./MMCD – Aluminum Housing
		Pedestrian Heads	<ul style="list-style-type: none"> McCain Eagle 	Current ITE Specifications – Aluminium Housing
2.17.	LED Signal Modules	LED Vehicle Display	<ul style="list-style-type: none"> Dialight Leotek 	M.O.T.I Current ITE Specifications
		LED Pedestrian Displays	<ul style="list-style-type: none"> Dialight Leotek 	Current ITE Specifications C/W countdown timer

MMCD Section	Product	Approved Material / Type	Approved Product/Manufacturer	Restrictions/Additional Specifications
2.19	Sign Mounting Hardware	Overhead adjustable Bracket	Pelco	Astro-brac
		Side mount Brackets	Greenlite Traffic	M.O.T.I – GEL 189
2.21.	Pedestrian / Cyclist Pushbuttons	Push Button Sign Unit	Polara	Navigator APS EZ 2 wire C/W Central Control and Ped Station Monitor Unit.
2.28	Uninterrupted Power Supply	UPS	Alpha	FXM Series
2.32	Extruded Aluminium Signs	Streetname Sign Mount	Fortran	Can-Brac assembly
		Special Crosswalk Controller	Novax	PXO-II
		Fire Hall Signal Controller	Novax	ELA515

END OF SECTION

MMCD Section 03 30 20

Concrete Walks, Curbs and Gutters

1.0 GENERAL

1.4 Measurement and Payment

Append to 1.4.3 Payment shall also include joint and surface finishing. Curb within the area ramp or driveway crossing is considered regular curb for the purpose of payment.

Append to 1.4.5 Payment will be on actual area placed, unless noted otherwise in the Schedule of Quantities and Prices.

Delete 1.4.6 and replace with Concrete driveway crossing will be based on actual area placed for different types of finishes and thickness. Payment shall be for those driveways noted on the Contract Drawings, and include grading of base gravels, supply and placement of concrete and surface finishing.

Append to 1.4.8 Adjustment shall include: removal of existing frame and cover; cleaning; re-set to meet new grade, profile and cross fall; replace grade rings.

2.0 PRODUCTS

2.1 Materials

Amend 2.1.5.1 Minimum cement content should be 335 kg/m³.

Add 2.1.5.3 Exposed Aggregate Concrete shall be 32MPa 9.5mm Chilliwack Exposed mix.

Add 2.1.7

1. Colored Patterned Surface for median infill, splash strips, and maintenance vehicle parking pads shall be: 100mm thick stamped colored concrete splash strips or median infill except in maintenance vehicle parking area where concrete shall be 120mm thick.

2. Concrete color to be Brick Red or equivalent using Davis Pigment # 160 at rate of 30 pounds per cubic meter. Stamped concrete pattern shall be running bond pattern.

All coloured concrete to be sealed with clear/translucent sealer after installation and surface is swept clean.

2.2 Curbs & Gutters

Add 2.2.1 On all roads with bike lanes, curb/gutter/catch basins adjacent to the bike lane shall be bike friendly as per Standard Drawing.

Apr. 2020

Add 2.2.2 All references to concrete barrier curb shall be the narrow base barrier curb as per the Standard Detail Drawing C4, unless approved otherwise by the City.

3.0 EXECUTION

3.13 Special Effects

Add 3.13.3 Exposed aggregate concrete shall be placed in similar fashion as regular concrete finish, except:

- .1 Concrete surface shall be washed to expose the aggregates underneath after concrete has been set.
- .2 During the wash, all washed water shall be collected and disposed in accordance with the local Best Management Practices.
- .3 Disposing the washed water into the storm or sanitary system will not be permitted.
- .4 In instances where disposal offsite is not achievable, with the approval of the Contract Administrator, the Contractor may install an onsite collection pond to store and dissipate the washed water through infiltration.

END OF SECTION

MMCD Section 03 30 53

Cast-in-Place Concrete

1.0 GENERAL

1.4 Measurement and Payment

Append to 1.5.5 Payment will be on an individual basis for the complete headwall or other structure being constructed.

3.0 EXECUTION

3.5 Acceptance

Add 3.5.1 Concrete shall develop a minimum compressive strength of 32 MPa at 28 days based on standard cylinder test, performed in accordance with CSA A23.2-9C, based on concrete cylinders collected on the day of placement.

Add 3.5.2 One strength test (3 specimen cylinders) shall be made for each 100 square metres of concrete work. In no case, however, shall there be less than one strength test for concrete placed in one day. One cylinder shall be tested at 7 days, 2 cylinders shall be tested at 28 days.

Add 3.5.3 The core test shall be performed in accordance with CSA 23.2-14C. The compressive strength of the concrete, based on core tests, shall be interpreted from CSA A23.1-94.

Add 3.5.4 In the event that the cylinders, tested at 28 days, fail to achieve the specified 32 MPa, the Contractor shall, upon notification, obtain cores for further testing. The cores are to be drilled from the portions of the structure in question and tested prior to day 38.

Add 3.5.5 Concrete not meeting the minimum compressive strength criteria shall be rejected and must be removed and replaced at the Contractor's expense.

END OF SECTION

MMCD Section 26 05 34S

Conduit for Communication Network

- 1.0 GENERAL** .1 This Section refers to those portions of the work that are unique to the supply and installation of communications conduit, service boxes, service vaults for Surrey's Communications Network.
- 1.1 Related Work** .1 Section 31 24 13 Excavating, Trenching and Backfilling
- 1.2 References** .1 CSA C22.2 NO. 211.2-[M1984 (R2003)], RIGID PVC (UNPLASTICIZED) CONDUIT.
- 1.3 Record Drawings** .1 Contractor to provide information on all changes, additions and deletions to Contract Drawings to reflect "as constructed" installation, including final locations of all equipment installed, per Section 01 33 01 Project Record Documents. All drawings must be submitted to the Contract Administrator no later than 14 days after Substantial Performance.
- 1.3 Measurement and Payment** .1 Payment for the supply and installation of conduits and related appurtenances as specified in the Contract Drawings shall be Lump Sum.
- 2.0 PRODUCTS**
- 2.1 General** .1 All products must bear evidence of either a mark or a label of a certification agency accredited by the Standards Council of Canada or an approved label issued by the BC Safety Authority.
- 2.2 Conduit** .1 Rigid PVC Conduit (RPVC):
- .1 Conduit-Rigid polyvinyl chloride to conform to CSA C22.2 No. 211.1.
 - .2 Couples, Adaptors, Bends and Fitting – Rigid polyvinyl chloride to conform to CSA C22.2 No. 85
 - .3 Cement-CSA certified as recommended by RPVC manufacturer
- 2.3 Trench Marker Tape** .1 Minimum 150 mm wide, minimum 3.5 mm thick, heavy duty polyethylene. Orange with black letters displaying: "WARNING- COMMUNICATIONS CABLE BURIED BELOW".
- 2.4 Concrete Communication Vaults** .1 Concrete communication vaults to conform to Section 203 Concrete Vaults, Junction Boxes, Manholes, BCMOT E&SMS V1 with the following exception:
- .1 Concrete Vaults: Refer to Drawings SSD-E10.11 to E10.13

Apr 2020

3.0 EXECUTION

- 3.1 General** .1 .1 Lay out work as shown on Contract Drawings.
- .2 Confirm location of all works to be installed with Contract Administrator.
- .3 Take reasonable precautions necessary to prevent damage to existing utilities. Any damage to utilities must be repaired to satisfaction of Contract Administrator.
- 3.2 Excavating, Trenching and Backfilling** .1 Refer to Section 31 23 01 – Excavating, Trenching and Backfilling for conduits, boxes, vaults etc.
- 3.3 Underground Conduit** .1 .1 Install R.PVC underground conduits in open trenches as shown on Standard Detail Drawings unless shown otherwise on Contract Drawings.
- .2 Minimum cover over conduits to be 760mm.
- .3 Place trench marker tape above installed conduit trench. Trench marker tape not required for conduits installed via trenchless technology.
- .4 Conduits shall be blown out with compressed air, from both ends if necessary and then swabbed out to remove stones, dirt, water and other materials which may have entered during installation. If conduit deformation is suspected, use a mandrel ½” smaller than the conduit diameter and prove the conduit.
- .6 All empty conduits shall have a 6 mm nylon pull string installed and capped ends.
- .7 Unused conduit stub ends to be capped and location marked on as-built records. Marker balls or epoxied surface tags can also be considered for this purpose.
- 3.4 Conduit Bends** .1 Conduit shall not be bent in the field. Manufactured (factory) bends must be used. Offsets, however, are allowed within manufacturer’s specifications. Where specifications do not exist, deflect no more than 10” for a 10’ section or 36” for a 20’ section of 4” PVC DBII pipe.
- All manufactured bends to be 0.914m radius unless otherwise noted.

3.5 Conduit Joints

.1

Solvent cementing procedures are as follows:

- .1 Deburr the inside and outside diameters of the spigot end of the conduit.
- .2 Remove all dirt and moisture from the outside of the spigot and the inside of the socket.
- .3 Before applying the cement, push the spigot into the socket to ensure they fit together properly.
- .4 Apply solvent cement to the outside of the spigot and the inside of the socket.
- .5 Push the spigot into the socket until it bottoms. Twist it a $\frac{1}{4}$ turn to ensure that the solvent is spread around the entire joint.
- .6 Hold together for a few seconds until a joint is created.

Solvent cemented joints may appear to set immediately, but it can take up to 24 hours for the joint to completely cure.

END OF SECTION

MMCD Section 26 56 01 Roadway Lighting

1.0 GENERAL

1.4 Electrical Energy Supply Add 1.4.4 The Contractor shall coil and tape conductors out of weather head. Utility company shall complete electrical service connections.

2.0 PRODUCTS

2.1 General Append to 2.1.2 All products must bear evidence of either a mark or a label of a certification agency accredited by the Standards Council of Canada or an approved label issued by the BC Safety Authority.

Replace 2.1.3 All products shall be in accordance with Section 01 62 01S.

2.4 Plastic Junction Boxes Append to 2.4.1 Lids for plastic junction boxes to be galvanized.

2.5 Concrete Junction Boxes Delete 2.5.1 and replace with Refer to Drawing SSD-R.E.6 and R.E.7 for concrete junction box details.

2.7 Poles and Anchor Bolts Append to 2.7.1 Roadway Lighting poles shall be Type S or L Shafts as defined on the Contract Drawings. Pole specifications vary by neighbourhoods and the latest specifications are available from the City's Engineering Traffic Operations Section.

2.8 Conductors and Cables Add 2.8.5 Roadway Lighting Feeder Conductors: 600V, conductor size (AWG) as noted on Contract Drawings, stranded aluminum type with RW90 polyethylene insulation, to conform to CSA C22.2 No. 38, 90°C, and color coded as per CEC.

All new roadway lighting systems shall be constructed with underground aluminum conductors. System bonding conductors shall be aluminum. Service Panel grounding conductor shall be copper. Pole raceway conductors shall be RW90 stranded copper.

2.10 Conductor Connectors Delete 2.10.1 and replace with Compression Type: Connectors shall accommodate combinations of aluminum to copper, and aluminum to aluminum conductors. Size to suit conductor gauge and number of conductors.

2.14	Luminaires	Delete 2.14.1 and replace with	All luminaires shall be LED.
		Delete 2.14.2 and replace with	All luminaires shall be LED.
3.0	EXECUTION		
3.1	General	Add 3.1.5	When tying into or upgrading an existing installation, maintain the existing lighting system operation during the hours of darkness.
3.5	Underground Conduits	Delete 3.5.2 and replace with	Minimum cover over conduits to be 600mm in boulevard areas and 900mm in travelled areas.
		Add 3.5.6	Before pulling conductor cable/wire into a run of conduit, the conduit shall be blown out with compressed air, and pull string installed with caps at each end. Conductors shall be pulled in slowly by hand or hand winch, in order to keep close control on pulling tension and prevent cutting the conduit at bends.
3.8	Wiring	Delete 3.8.3 and replace with	See Drawing SSD-R.E.13 for splice details. Delete reference to solderless type connectors as connectors shall be compression type. Use tool recommended by the connector supplier to make splices. Connectors shall be prefilled with an oxide-inhibiting joint compound.
		Delete 3.8.8 and replace with	Secure conductor splices with compression type connectors. Install using manufacturer recognized mechanical or hydraulic compression tools and matching die set. An oxide-inhibiting joint compound shall be used for terminating or splicing all aluminum conductors.
3.10	Luminaires and Photocells	Add 3.10.4	NEMA wattage label shall be visible at the bottom of the luminaire on all fixtures. Place label on the underside of the luminaire for cobra heads and on the neck or top of pole for post tops.

END OF SECTION

MMCD Section 31 05 17

Aggregates & Granular Materials

1.0 GENERAL

1.5 Inspection and Testing Add to 1.5.2 Sieve analysis and proctors are required for each type of material to be used prior to the commencement of Work and every 1,000 tonnes during the Work.

2.0 PRODUCTS

2.7 Granular Pipe Bedding and Surround Material Change 2.7 Delete "Recycled concrete free from contaminated and other extraneous material, conforming to the Type 1 gradations, may be used as pipe bedding and surround material.

2.10 Granular Base Delete 2.10.2 Delete the use of Type 2 – 19mm crushed gravel.

END OF SECTION

MMCD Section 31 11 41

Shrub and Tree Preservation

1.0 GENERAL

1.3 Measurement and Payment

Delete 1.3.1 and replace with

Payment for all shrub and tree preservation, including tree protection fencing, grading, exposing root zone and hand excavation, and works deemed necessary by a certified arborist or the Contract Administrator, is applicable to all work performed under this Section, and incidental to payment for work described in other Sections unless shown otherwise in the Schedule of Quantities and Prices.

END OF SECTION

MMCD Section 31 15 60

Dust Control

3.0 EXECUTION

3.1 Application

Append to
3.1.1

Control of dust and sediment is critical. The Contractor will regularly scrape, sweep and clean the roads. The sites must be maintained in a professional manner to ensure that the works does not adversely affect the residents in the area. Dust and sediment build-up on adjacent surrounding roads or grounds is not permitted and must be immediately removed by the Contractor.

Append to
3.1.3

Aqueous chloride and magnesium cannot be used for work areas within 100m of a watercourse, and work areas that are draining to a watercourse.

Add 3.1.5

The Contract Administrator may request additional street cleaning which shall be promptly undertaken at the Contractor's expense.

Add 3.1.6

If the Contractor fails to maintain dust and sediment control the City can carry out the dust and sediment control as needed and costs will be charged against the Contractor.

END OF SECTION

MMCD Section 31 22 01

Site Grading

1.0 GENERAL

1.4 Measurement and Payment

Delete 1.4.1 and replace with

No separate payment will be made for topsoil stripping, unless noted otherwise in the Schedule of Quantities and Prices, as payment for this work shall be included in rough site grading and common excavation.

Append to 1.4.2

Rough site grading and redistribution of excavated materials to design elevations and grades will be paid on a volumetric basis, measured in cubic meters based on before and after surveyed cross sections measured at a maximum 20 meter interval.

3.0 EXECUTION

3.2 Grading

Delete 3.2.2 and replace with

Works shall be carried out in accordance with Section 31 23 01 - Excavating, Trenching and Backfilling - 3.5.4, except Provincial Highways where the compaction shall be 95% Modified Proctor density.

3.3 Tolerances

Delete 3.3.1 and replace with

Accuracy of subgrade elevations to be within tolerances shown in Table 2.

Table 2: Tolerances for Subgrade where Growing Medium (Topsoil) to be Placed Over Subgrade

Intended Growing Medium Depth	Tolerance
0 – 150mm	25mm +/-
151 – 300mm	25mm +/-
301 – 600mm	50mm +/-

END OF SECTION

MMCD Section 31 23 01

Excavating, Trenching and Backfilling

1.0 GENERAL

1.3 Definitions

Append to
1.3.4

Removals shall also include asphalt; concrete; driveways; street lights and traffic signals and their bases; electrical and communication conduits and vaults; fences; handrails; and similar works.

1.8 Limitations of Open Trench

Append to
1.8.1

If open trench is in, or adjacent to, a road or sidewalk, permission is required from the City and in the event the City permits steel road plates they shall be designed by a Professional Engineer and pinned down.

1.10 Measurement and Payment

Append to
1.10.1

Payment for works in this Section shall include excavation, shoring, trench and site dewatering, hauling and disposal, of surplus soil.

Append to
1.10.7

Cleaning and deepening of existing channel or ditch shall be paid on a lineal metre basis as measured along centerline, unless noted otherwise in the Schedule of Quantities and Prices.

Append to
1.10.8

Payment for boulevard swale shall be measured on a lineal metre along centerline, unless noted otherwise in the Schedule of Quantities and Prices.

1.11 Inspection and Testing

Add 1.11.2

For items that are measured by weight, the Contractor shall:

- .1 Co-ordinate his Work so that no more than one Contract Administrator representative is required to witness, collect and check the weigh tickets at any one time.
- .2 Arrange weigh tickets to be collected and verified at specific locations on the Site, and on the same day as material is delivered, as agreed by the Contract Administrator.

The Contract Administrator and Owner may refuse approval of tickets received after the day of placement. Payment is only for the material completely incorporated into the Works as witnessed by the Contract Administrator's representative.

2.0 PRODUCTS

- 2.2 Use of Specified Materials**
- Delete 2.2.1 and replace with
 - Delete 2.2.3 and replace
- Backfill for over-excavated trench shall be imported 75mm Pit Run Gravel as specified in Section 31 05 17 - 2.3
- Trench backfill to be imported granular material as per Drawing SSD-G.4.

3.0 EXECUTION

- 3.2 Stockpiling**
- Add 3.2.2
- Carefully dismantle and stockpile items containing materials for salvage, and dispose excess materials after salvage is completed.

- 3.3 Excavation**
- Add 3.3.13
- Asbestos pipe and products to be removed and disposed by Contractor, in accordance with Work Safe BC requirements.

- 3.5 Backfill and Compaction**
- Append to 3.5.4.1
 - Add 3.5.4.4
- Boulevard and easement along Provincial Highways and shall be compacted to 95% Modified Proctor density.
- Trench backfill, road subgrade and embankment fill shall be placed and compacted in 0.300m vertical lifts, or less, along the entire length. As a minimum, the frequency of quality control testing for compaction densities for trench backfill, road subgrade and embankment fill shall be at least one test per 50 lineal metres of trench, or lane width, and the number of tests shall vary per vertical depth:

- .1 Trench backfill, Subgrade and embankment fill 0.600m or less shall include 1 vertical test per 50m;
- .2 Trench backfill, Subgrade and embankment fill between 0.600m and 1.8m shall include 2 vertical test per 50m, with vertical test intervals being equally spaced;
- .3 Trench backfill, Subgrade and embankment fill greater than 1.800m shall include 3 vertical test per 50m, with vertical test intervals being equally spaced;

- 3.6 Surface Restoration**
- Delete 3.6.6.1 and 3.6.6.2 and replace with
 - .1 Place temporary pavement on arterial and collector roads within 72 hours of when the excavation is made. During the 72 hours the use of a steel road plates is required.

- .2 Patch all other roads within 5 calendar days, and by the end of each work week, of when the excavation is made. During the 5 Calendar Days period the road may remain in an even gravel surface, with a minimum of 75mm of 19mm minus granular road base compacted to 95% Modified Proctor density.
- Add 3.6.6.6 .6 Ensure the temporary gravel surface is even and does not have irregularities exceeding 10mm when checked with a 3m straightedge placed in any direction.
- Delete 3.6.7.1 and 3.6.7.5 and replace with .1 Install permanent pavement within 60 calendar days of placement of temporary patch, weather permitting, and upon confirmation of passed testing results for trench compaction. The *Contractor* may elect to repair the pavement cut with a permanent pavement restoration, and forgo the temporary pavement patch, provided the permanent pavement restoration can be completed within the timeframe specified in Section 3.6.1 and 3.6.2.
- .5 Restore pavement as detailed on Drawing SSD-G5.
- Add 3.6.7.11 .11 During the permanent pavement restoration, the permittee may elect to mill the surface of the pavement cut area leaving a portion of the temporary pavement patch, provided the permittee has confirmed by way of test and inspections that:
- 1.1 All broken, cracked, settled pavement (within the temporary pavement patch location) has been removed. Confirmation will be provided by the permittee by way of pictures and inspections;
 - 1.2 The temporary pavement patch has been installed using hot-mix asphalt and at a consistent pavement thickness in accordance with Drawing SSD-G.5;
 - 1.3 The temporary pavement patch has been tested for asphalt thickness and densities, in accordance with Section 32 12 16 and/or Section 32 12 16; and

Apr. 2020

Apr. 2020

- 1.4 The temporary pavement patch has been installed during dry weather and with temperatures greater than 10 degrees

END OF SECTION

MMCD Section 31 24 13

Roadway Excavation, Embankment and Compaction

1.0 GENERAL

1.3 Definitions

Amend 1.3.1

Change wording to read “three classes” of excavation and add 1.3.1.3 as follows:

- .4 Mass Excavation: As defined as “Removals” under Section 31 23 01 – Excavating, Trenching and Backfilling – 1.3.

1.8 Measurement and Payment

Delete 1.8.4 and replace with

Payment for Mass Excavation (or Removals), as defined in paragraph 1.3.1 of this Section, will be on a Lump Sum basis, unless noted otherwise in the Schedule of Quantities.

Delete 1.8.5 and replace with

Payment for Common Excavation includes that defined in paragraph 1.3.1.2 of this Section including striping, removal and disposal of grass, sod and topsoil.

Payment for Common Excavation shall be as follows, unless noted otherwise in the Schedule of Quantities and Prices:

- .1 The initial cross sections will be taken after Mass Excavation and Clearing and Grubbing are complete. The final cross sections will be taken upon completion of excavation to lines and levels required prior to placing of other materials over the excavated surface.
- .2 Payment for on-site re-use includes stockpiling, double handling and hauling, moisture conditioning, placement, grading and compaction. Payment will be on a volumetric basis, calculated from cross-sections at sufficient and equal intervals as determined by the Contract Administrator.

Delete 1.8.9 and replace with

Payment shall include finish grading, removal of surplus material, placement of additional gravels, adjustment of moisture content and compaction to obtain the required grades and cross section.

Payment for subgrade preparation under sidewalks, curbs and boulevard strips shall be included in their respective sections.

3.0 EXECUTION

3.5 Compaction

Add 3.5.7

The frequency of density tests shall be one test per 250m² per 300mm vertical lift.

3.7 Proof Rolling

Add 3.7.6

If the Contractor disagrees with the Contract Administrator's determination of soft areas, density tests, Benkelman beam testing or other mutually acceptable testing shall be carried out and be the determining criteria.

END OF SECTION

MMCD Section 32 01 11

Pavement Surface Cleaning and Removal of Pavement Markings

1.0 GENERAL

**1.2 Measurement
and Payment**

Delete 1.2 and
replace with

Payment for pavement cleaning surfaces, removal of pavement markings and related work will be incidental to Work described in other sections, unless noted otherwise in the Schedule of Quantities.

END OF SECTION

MMCD Section 32 01 16.7 Cold Milling

1.0 GENERAL

- 1.1 Related Work**
- Add 1.1.6 Hot-Mix Asphalt Concrete Paving - Section 32 12 16.
 - Add 1.1.7 Superpave Hot-Mix Asphalt – Section 32 12 17.
 - Add 1.1.8 Full Depth Reclamation - Section 32 01 16.8
- 1.5 Measurement and Payment**
- Append to 1.5.3 Payment for reusing milled material onsite shall also include, stockpiling and double handling, spreading, grading and compacting milled material.
 - Add to 1.5.4 Payment for supply, installation and removal of temporary asphalt slope around manholes, valve covers and utility covers is incidental to the milling work.

3.0 EXECUTION

- 3.1 Equipment**
- Add 3.1.2 Grader mounted grinders are not acceptable for this Work.
 - Add 3.1.3 The existing asphalt concrete shall be milled by equipment suitable to produce a well graded material with the largest aggregate size not exceeding 25mm.
- 3.2 Preparation**
- Add 3.2.4 All manhole rims, valve covers, and utility cover lids must have an asphalt slope from the top of the lid to milled surface of sufficient length to prevent damage to vehicular traffic. These slopes are to be completely removed immediately prior to final paving. These appurtenances must be monitored until final paving. Use of temporary sloped collar will also be acceptable for a period of less than 7 days.
 - Add 3.2.5 Minimum milling: Depth – 35mm
Width – 1.2 metre
- 3.3 Stockpiled Material**
- Add 3.3.3 Subject to prior approval of the Contract Administrator, the milled material shall be used onsite for road base and sub-base. The Contract Administrator will determine the mixture ratio between the milled material and the imported base and sub-base material and the method of placing.
- 3.4 Placing**
- Append to 3.4.4 The material shall be bladed to proper grade and cross section as directed.

Add 3.4.6

Unless otherwise specified in writing by the Contract Administrator, the milling of the existing asphalt shall be followed by repaving within five (5) Days of the commencing of the milling. The milled asphalt surface shall be graded, monitored, signed and maintained at no additional cost to the Owner.

END OF SECTION

MMCD Section 32 11 16.1 Granular Subbase

3.0 EXECUTION

- 3.3 Compaction** Add 3.3.6 The frequency of density tests shall be at least one test per 150 square metres placed, minimum one per day, and test interval shall be consistent and evenly spaced along length and width of Work. For Work that involves roadway, curb and sidewalk, test locations shall be staggered amongst the travelled lanes, curbs and sidewalks.

END OF SECTION

MMCD Section 32 11 23

Granular Base

3.0 EXECUTION

3.3 Compaction

Add 3.3.6

The frequency of density tests shall be at least one test per 150 square metres placed, minimum one per day, and test interval shall be consistent and evenly spaced along length and width of Work. For Work that involves roadway, curb and sidewalk, test locations shall be staggered amongst the travelled lanes, curbs and sidewalks.

3.5 Proof Rolling

Delete 3.5.1 and replace with

Contractor is also responsible for proof rolling granular base course grade prior to paving and placement of concrete curb and sidewalks. Contractor to complete Benkelman Beam testing in the presence of the Contract Administrator prior to any paving work.

END OF SECTION

MMCD Section 32 12 16

Hot-Mix Asphalt Concrete Paving

1.5 Measurement and Payment

Append to 1.5.4	No additional payment will be made for hand formed curbing.
Delete 1.5.7 and replace with	No additional payment will be made for saw cutting asphalt concrete or curbs; Portland cement concrete or curbs; curbs, gutters, or sidewalks; including the requirement for neat lines and tie-ins. Payment for this work will be incidental to payment for work described in other Sections.
Delete 1.5.8 and replace with	Payment for permanent reinstatement of pavement includes all work under Section 31 23 01 – 3.6.7.
Add 1.5.9	Payment for pavement patching is defined as isolated or segmented areas of pavement repair that are less than 10 square meters in area. Payment shall include saw cutting, excavation, and removal of existing asphalt, fine grading and compaction of base, tack coat, prime coat, and all other works described in 1.5.1 of this Section.
Add 1.5.10	Payment for stamped asphalt concrete surfaces shall be as per 1.5.3 of this Section.

1.6 Inspection and Testing

Add 1.6.3	The frequency of Marshall tests shall be one test for each asphalt type, minimum one per day, per site/location.
Add 1.6.4	For road paving, core locations will be selected for each pass of the paving machine as follows: .1 Across the width, core locations will be selected randomly from each lane. .2 Along length, core locations should be spaced evenly every 75 metres, with a minimum of 2 core samples required for lengths shorter than 150m.
Add 1.6.5	For other paving operations, a minimum of one core for every 500 square metres of asphalt mix placed. For area less than 1500 square metres, a minimum of 3 cores will be required. For areas less than 500 square metres, testing frequency will be at the direction of the Contract Administrator.

		Add 1.6.6	A section of pavement is deemed to have met the specification for compaction if the cores average 97% or more of the 75 blow Marshall density obtained in an approved hot mix laboratory test conducted on an actual field sample with no individual core less than 95%. For this purpose, a section of pavement is defined as an area the width of one pass of a paving machine by the length required to obtain 5 consecutive cores.
		Add 1.6.7	A section of pavement is deemed to have met the specification for thickness if the average of 5 consecutive cores is within 5mm tolerance of the design thickness with no individual core more than 6mm thinner than the design thickness.
		Add 1.6.8	Acceptance will be based on an appropriate combination of cores, hot- mix test results, and smoothness / ride ability of the surface.
		Add 1.6.9	Core holes shall be reinstated to the satisfaction of the Contract Administrator.
2.0	PRODUCTS		
2.2	Mix Design	Amend 2.2.3.3	Change references to ASTM D1559 to ASTM D6927.
2.3	Stamped Asphalt Surface	Add 2.3.1	Where specified as stamped asphalt, colored patterned surface for median infill, splash strips, and maintenance vehicle parking pads shall be: 50mm thick stamped colored asphalt for splash strips or median infill, and 75mm in maintenance vehicle parking area. Asphalt color to be "Terra-cotta" as supplied by Integrated Paving Concepts or Approved Equivalent, and stamped pattern shall be running bond.
3.0	EXECUTION		
3.3	Preparation	Append to 3.3.3	Contractor shall inform utility agencies with sufficient notice in regard to the affected utility covers. The Contractor shall loosen the utility covers and make adjustment. Adjustment may be completed by the Agency or deferred to the Contractor. Adjustment shall be completed at least one day prior to paving.
		Append to 3.3.6	Prior to final paving, reinstate disturbed detector loops and complete paving and reconnection of the loops.

		Add 3.3.7	When removing reclaimed asphalt pavement (RAP) for subsequent incorporation into hot mix asphalt concrete paving, prevent contamination with base aggregates.
3.5	Placing	Add 3.5.3.4	The asphalt mix shall be placed at a temperature between 135°C and 163°C measured in the mat immediately behind the paver.
3.7	Joints	Delete 3.7.4 and replace with	All joints shall be butt joints.
3.9	Asphalt Sidewalks and Driveways	Add 3.9.6	Sidewalks and driveways shall not be opened to pedestrians or vehicles until the mix has cooled sufficiently to prevent deformation.
		Add 3.9.7	Curbs shall be machine extruded. The weight of the placing machine shall be such that compaction is obtained without the machine riding above the bed on which the curb is constructed. The machine shall form curbing that is uniform in texture, shape and density. The curbs shall be placed to an accurate alignment. The curbs shall be protected from traffic by barricades or other suitable methods until the curb has hardened.
3.9	Finished Tolerances	Append to 3.9.1	Finished asphalt surface to be within 20mm horizontally from design alignment.

END OF SECTION

MMCD Section 32 12 17

Superpave Hot-Mix Asphalt Concrete Paving

- | | | | |
|------------|--------------------------------|-----------|--|
| 1.0 | GENERAL | Add 1.0.6 | Work required in this Section shall be in accordance with the latest version of the City's Engineering Department Pavement Cut Practice and Procedure. |
| | | Add 1.0.7 | All pavement on Arterial Roads shall be Superpave Hot-Mix Asphalt Concrete. |
| 1.5 | Measurement and Payment | Add 1.5.9 | Payment for sawcutting asphalt concrete or Portland cement concrete pavement for temporary and permanent pavement restoration will be incidental to payment for work described in other Sections. |
| 1.6 | Inspection and Testing | Add 1.6.3 | For Superpave Hot-Mix asphalt, the frequency of Gyratory, moisture content, asphalt content and percent fracture tests shall be one test for each asphalt type, minimum one per day and minimum one per 500 tonnes. |
| | | Add 1.6.4 | For road paving, random core locations will be selected for each lane, or pass of the paving machine, but not to exceed 75m in length.

For other paving operations, a minimum of one core for every 500 square metres of asphalt mix placed. For area less than 1500 square metres, a minimum of 3 cores will be required. For areas less than 500 square metres, testing frequency will be at the direction of the Contract Administrator. |
| | | Add 1.6.5 | A section of pavement is deemed to have met the specification for compaction if the cores have achieved the compaction requirements of 3.6 in this Section, when conducted by a CCIL certified asphalt laboratory on actual field hot-mix sample. |
| | | Add 1.6.6 | A section of pavement is deemed to have met the specification for thickness if the average of 5 consecutive cores is within 5mm tolerance of the design thickness with no individual core more than 6mm thinner than the design thickness. |
| | | Add 1.6.7 | Acceptance will be based on an appropriate combination of cores, hot-mix test results, and smoothness / ride ability of the surface. |

Add 1.6.8 Core holes shall be reinstated to the satisfaction of the Contract Administrator.

2.0 PRODUCTS

2.1 Materials

Append to 2.1.1 Superpave asphalt cement must meet or exceed Performance Grade PG 64-22.

Delete 2.1.2 and replace with Reclaimed asphalt pavement (RAP): processing, quality and use to requirements of NCHRP Report 452 and Table 1, with a RAP incorporation limit not to exceed 10% in lower course Superpave HMA and 10% in upper course Superpave HMA.

Append to 2.1.3.1 Lower course to be Superpave 19mm aggregate size mix, and Upper Course to be Superpave 12.5mm mix.

Apr. 2020

Amend 2.1.4 In Table 1, maximum allowable RAP shall be 10%.

Add the following notes below Table 1:

7. The amount of total AC replaced by AC in the RAP will be calculated as follows:

$$\% \text{ AC Replacement} = (a \times b) / c$$

Where:

a = AC content of RAP

b = RAP percent in mixture by total weight of mix

c = Total percent AC content in mixture

.8 Rejuvenators and softening agents not permitted

.9 Asphalt Shingles not permitted.

2.2 Mix Design

Append to 2.2.2 Mix design gradation curve to be based on at least five (5) samples for each aggregate type.

3.0 EXECUTION

3.1 Plant and Mixing Requirements

Add 3.1.4.4 Air voids shall be between 3.0 – 5.0%.

3.3 Preparation

Append to 3.3.3 Contractor shall inform utility agencies with sufficient notice in regard to the affected utility covers. The Contractor shall loosen the utility covers and make adjustment. Adjustment shall be completed at least one day prior to paving.

		Add 3.3.7	When removing reclaimed asphalt pavement (RAP) for subsequent incorporation into hot mix asphalt concrete paving, prevent contamination with base aggregates.
3.5	Placing	Append to 3.5.1	Contractor shall prepare and submit a Quality Control Plan to the Contract Administrator at least 7 days prior to paving. The plan shall include full details of: .1 Plant test and gradation results, including date sampled / tested .2 Equipment, number of trucks, placement rate .3 Contemplated rolling patterns .4 Testing for control of density.
		Add 3.5.3.4	The asphalt mix shall be placed and compacted at a temperature range determined from the Viscosity – Temperature Chart from 250-310 cST (compaction range) for the asphalt cement type being used, and to be measured in the mat immediately behind the paver.
3.7	Joints	Delete 3.7.4 and replace with	Feather joints are not permitted.
3.10	Finished Tolerances	Append to 3.10.1	Finished asphalt surface to be within 20mm horizontally from design alignment.

END OF SECTION

MMCD Section 32 14 01

Unit Paving

1.0 GENERAL

1.6 Measurement and Payment

Delete 1.6.3 and replace with

Payment for unit paving should be measured in square metres, unless noted otherwise in the Schedule of Quantities and Prices. The price shall include the supply and installation of all materials, including pavers of varying color, size and type, edging, granular laying course, bedding sand, joint sand, cutting of all edges to fit, compaction, adjusting, leveling, cleaning surface of excess sand, and sealant.

2.0 PRODUCTS

2.1 Materials

Append to 2.1.4

Granular laying course sand shall have moisture content between 6.0% to 8.0%.

Append to 2.1.5

Boulevard or sidewalk pavers shall be a minimum 60mm thick.

Add 2.1.7

Concrete pavers shall conform to ASTM C939 to C982, specifications for solid concrete interlocking paving units.

Add 2.1.8

All concrete pavers shall be sealed with after installation and surface is swept clean.

3.0 EXECUTION

3.4 Granular Laying Course

Delete 3.4.1 and replace with

Granular laying course shall be spread evenly over the area to receive concrete pavers in one day and protected against weather. This bedding shall have a compacted thickness of 50mm, and graded to meet cross falls in boulevards, sidewalks and driveways.

3.5 Unit Paving

Delete 3.5.4.1 and replace with

Full units shall be installed first and edge pieces fitted subsequently. All pavers to have 3mm +/- joints.

Append to 3.5.4.2

Pavers shall be vibrated to their final level by having not less than 3 passes of a vibrating plate compactor. The compactor shall be a high frequency, low amplitude unit with plate sized to cover at least 12 pavers.

Append to 3.5.4.4

Jointing sand shall be spread over the paver surface and vibrated to completely fill all joints. Jointing sand shall be reinstalled after the first heavy rainstorm.

END OF SECTION

MMCD Section 32 17 23 Painted Pavement Markings

1.0 INTRODUCTION

1.5 Measurement and Payment Add 1.5.5 Payment for enhanced safety markings covers supplying all materials and completing all permanent enhanced safety markings shown on Contract Drawings.

2.0 PRODUCTS

2.1 Materials Add 2.1.6.10 The temporary traffic line shall be a 100mm x 300mm strip of prefabricated reflective yellow tape having an adhesive backing and shall be placed at 10 metre intervals along the center of pavement.

 Add 2.1.6.11 The temporary stop bar shall be 2 - 100mm continuous strips of prefabricated reflective white tape having an adhesive backing and placed across the travel lanes at traffic control intersections.

 Add 2.1.7 Permanent Pavement Markings to be as follows:

- .1 Extruded Thermoplastic screed for line markings, median markings, stop bars and bicycle symbols;
- .2 Colourized enhanced safety markings, such as "green" bike conflict zones and "red" que jumpers are to be Methyl Methacrylate (MMA).

3.0 EXECUTION

3.3 Application Append to 3.3.2.1 Survey layout to be at 500mm intervals and markings to be placed within 24 hours of final lift of paving.

 Delete 3.3.3.3 and replace with Thermoplastic material shall be heated in the melter to a temperature of 195° C.

END OF SECTION

MMCD Section 32 31 13

Chain Link Fences and Gates

3.0 EXECUTION

3.3 Installation of Gates

Add 3.3.1 Install gates and gate stops in locations as shown on Contract Drawings.

Add 3.3.2 Level ground between, and around, gate posts and set gate bottom approximately 40mm above ground surface.

Add 3.3.3 Determine position of center gate rest for double gate. Cast gate rest in concrete as directed and dome concrete above ground level to shed water.

3.4 Touch Up

Add 3.4.1 Clean damaged surfaces with wire brush removing loose and cracked coatings. Apply two coats of organic zinc-rich paint to damaged areas. Pre-treat damaged surfaces according to manufacturer's instructions for zinc-rich paint.

3.5 Cleaning

Add 3.5.1 Clean and trim areas disturbed by operations. Dispose of surplus material as specified in Contract Documents.

END OF SECTION

MMCD Section 32 91 21 Topsoil and Finish Grading

1.0 GENERAL

1.5 Inspection and Testing Add 1.5.2 Contractor to provide an analysis of each type of material to be used prior to commencement of the Work and analysis of a minimum of 2 random samples of growing medium taken just before planting.

2.0 PRODUCTS

2.10 Growing Medium Amend 2.10 as follows Amend Table 2 in 2.10 to be as follows:

Table 2: Properties of Growing Medium

Criteria	Optimum Specification	Accepted Range
C/N Ratio	30	20 - 35
pH	6.8	6.0 - 7.5
Lime	0	0
Extract	3	2.5 - 5
Conductivity		
Sand	63%	50 - 68%
Fines	18%	10 - 25%
Organic Matter	19%	13 - 25%
Nitrogen	0.5	0.25 - 1.0
Phosphorus	250	125 - 350
Potassium	1500	1000 - 2500
Calcium	3000	2000 - 4000
Magnesium	400	300 - 600

3.0 EXECUTION

3.4 Placing Growing Medium Append to 3.4.5 Thickness of growing medium to be in accordance with the Drawings SSD-R.1 to SSD-R.10.

END OF SECTION

MMCD Section 32 92 23

Sodding

2.0 PRODUCTS

2.1 Sod

Add 2.1.8

Sod shall be free of fibrous net.

END OF SECTION

MMCD Section 32 93 01

Planting of Trees, Shrubs and Ground Covers

1.0 GENERAL

1.9 Measurement and Payment

Append to
1.9.1

Payment shall include excavation of the planter pocket, disposal, and supply and installation of structural topsoil or growing medium.

Add 1.9.3

Bark mulch shall be measured and paid on the basis of square metre of specified thickness. The unit prices shall include the supply and installation of the polyethylene sheets and bark mulch; spreading and grading.

2.0 PRODUCTS

2.1 Plant Material

Add 2.1.13

All Tree and shrub species to be in accordance with the City's Parks, Recreational and Culture Standard Construction Documents, including species, caliper, and branch elevation above finished ground.

3.0 EXECUTION

3.3 Planting

Add 3.3.4.5

Around base of trees and shrubs, apply 75mm thick layer of bark mulch over soil surface, maintaining a separation distance of 100mm between the mulch and the trunk of the tree or shrub.

3.5 Watering

Append to
3.5.1

Frequency of watering to be weekly during summer months, if plantings are less than 4 months of age, otherwise frequency shall be on a monthly basis as a minimum.

END OF SECTION

MMCD Section 33 01 30.1

CCTV Inspection of Pipelines

1.0 GENERAL

1.2 References

Delete 1.2.2.1 National Association of Sewer Service Companies and replace with (NASSCO), latest version of the Pipeline Assessment and Certification Program (PACP).

Add 1.2.3 In this Section, replace all references to “NAAPI” with “NASSCO”.

Add 1.2.4 In this Section, replace all references to “WRc” with “PACP”.

1.6 Measurement for Payment

Delete 1.6.6 and replace with Separate payment will not be made for flow control or bypass pumping as that work is to be included in the unit rates for CCTV inspection.

Add 1.6.7 Separate payment will not be made for reverse set-up cleaning and inspection, nor traffic control as that work is to be included in the unit rates for CCTV inspection.

2.0 PRODUCTS

2.1 Equipment

Add 2.1.1.5 Each unit is to be equipped with fans to remove fog that is present in the sewer at the time of the inspection.

Add 2.1.3.5 The focal range is to be adjustable from 100mm in front of the camera’s lens to infinity. The digital camera is to be capable of producing clear, sharp images at a minimum resolution of 800 x 600.

2.2 Materials

Delete 2.2.3 and replace with Digital report data and videos to be stored on a USB memory stick or web based server, with hardcopy backup on DVD-R, and provided to the City.

3.0 EXECUTION

3.1 CCTV Inspection

Append to 3.1.6 Conduct all inspections in the direction of flow unless a reverse set-up is required. Inspections are generally to begin with the upstream sewer in the system and proceed downstream in a consecutive manner. Inspection is not to proceed downstream until all contributing upstream sewers have been cleaned.

		Append to 3.1.14	If during the inspection clear water infiltration, flow disparity, or if there is a hole, void or collapse greater than 10%, capture an image and immediately notify the Contract Administrator.
		Append to 3.1.17	If inspection of an entire sewer cannot be completed due to collapse, deformation or solid debris, intruding connections, obstructions or large displaced joints, move the equipment to the upstream manhole and attempt inspection again. If complete inspection cannot be performed notify the Contract Administrator immediately.
3.8	Inspection Reporting Hard Copies & Digital Format	Append to 3.8.4	The digital output files shall be stored in Microsoft Access Database Format (*.mdb) and in a format compatible with the City's GIS (ArcMap) and internal software.
3.9	Flushing and Cleaning	Add 3.9.2	For sewers that are deemed by the Contract Administrator to be unacceptably cleaned, or not clear, CCTV video inspection reports will be rejected and the sewer shall be re-cleaned and re-videoed at the Contractor's expense.
3.11	Flow Reduction	Delete 3.11.1 and replace with	Reduce flow depth, through a combination of measures as outlined in this Section, to approximately 20% of the pipe diameter in order complete CCTV inspection.
3.12	Coding Accuracy	Add 3.12.5	On a random basis, the Contract Administrator may complete an independent Quality Assurance review of the inspection reports.

END OF SECTION

MMCD Section 33 01 30.2 Sewer Cleaning

1.0 GENERAL

Add 1.0.3 Sewer cleaning shall remove all debris from existing sewers and manholes to: alleviate blockages and prevent sewer backups, overflows and property damage; to restore hydraulic capacity; to reduce odors; to permit thorough CCTV inspection; and to allow rehabilitation works to be performed. Definitions for debris are generally consistent with the nomenclature contained in the National Association of Sewer Service Companies (NASSCO) Pipeline Assessment and Certification Program (PACP).

1.5 Measurement and Payment

Delete 1.5.4 and replace with Solid debris and root cutting and shall include removal and disposal of debris in existing sewers to an approved off-site facility. The length paid will be the total number of lineal meters cut, as authorized and approved by the Contract Administrator, and as verified by pre and post sewer inspection videos.

Add 1.5.5 Separate payment will not be made for reverse set-up cleaning.

3.0 EXECUTION

3.1 Sewer Cleaning

Add 3.1.1.5 Deliver notification letters to residents and businesses at least five (5) days prior to commencing work.

3.3 Root Removal

Delete 3.3.1 and replace with Obtain Contract Administrator's approval prior to undertaking any debris removal or root cutting.

END OF SECTION

MMCD Section 33 11 01

Waterworks

1.0 GENERAL

1.8 Measurement and Payment

Delete 1.8.4 and replace with

Payment for service connection includes mainline saddles where specified, corporation stops, curb stops, meter setter, boxes, service pipes and all related fittings and appurtenances specified and/or shown on Drawing SSD-W.1. Payment includes all applicable Work described in 1.8.2.

Measurement for service connections will be for each complete service installed, with no regard to length of service pipe installed.

Append to 1.8.10

Payment for casing pipe shall include the method of construction, such as open cut or trenchless technology, as noted on the Contract Drawings; and payment shall include excavation and backfill for casing pipe of access pits, casing spacers and end seals. Measurement for casing pipe will be made along the centerline of the casing pipe, over surface, after Work has been completed.

Delete 1.8.12 and replace with

There will be no payment for tie-ins to existing mains or service transfers when all work is to be undertaken by the City's Crew.

Add 1.8.14

Payment for hydrants includes the hydrant body, lateral connections from mainline tee off water main to hydrants, isolation valve at the mainline tee and curb valve with adjustable valve box, fittings and all other incidental Work as shown on the Drawings.

2.0 PRODUCTS

2.2 Mainline Pipe, Joints and Fittings

Delete 2.2.4.1 and replace with

Grey-iron (cast iron) fittings are not acceptable

Delete 2.2.4.10.1 and replace with

.1 Tie rods to be continuous threaded stainless steel, Type 304. Tie rods shall be the correct size for the lug opening and installed on all lugs provided with the minimum number of lugs and diameter to be as per the following table in order to achieve a safety factor of 2.0:

Nominal Pipe Size (mm)	Water Pressure (KPa)	Minimum Number of Tie Rods	Tie Rod Diameter
150	1380	2	20mm
200	1380	2	20mm
250	1380	4	20mm
300	1380	4	20mm
350	1380	4	20mm
400	1380	6	20mm
450	1380	8	20mm

Add 2.2.4.7.4 HDPE flanges to have epoxy coated, steel backup rings.

Delete 2.2.4.13.11 and replace with All joint restraints for PVC and PVCO water mains shall not be wedge style and shall be approved by the City and Manufacturer to not de-rate the pressure rating of the pipe.

Delete 2.2.5 and replace with Pre-stressed Concrete Pressure Pipe is not acceptable.

Add 2.2.7 Oriented Polyvinyl Chloride (PVCO) Pressure Pipe:

- .1 Pipe:
 - .1 Pipe to be manufactured to specifications for pipe size ranges as follows:
 - .1 Pipes 150 to 300mm dia. - AWWA C909
 - .2 Pipes to be pressure rated to minimum operating pressure of 1620 kPa (235psi)
 - .3 Pipes to be certified by Canadian Standards Association to CSA B137.3.1
 - .2 Outside diameter to be Cast Iron Pipe Size.
 - .3 To be compatible with specified mechanical joint and push-on joint fittings and valves without use of special adapters.
- .2 Joints: Push-on integrally thickened bell and spigot type to ASTM D 3139 with single elastomeric gasket to ASTM F477.

2.3 Valve Boxes and Lids

Delete 2.3.2.2 and replace with To AWWA C515: 400mm and larger to working pressure 1725 kPa, non-rising stem, hub, flanged or mechanical joint ends.

Delete 2.3.2.3 and replace with To AWWA C509: 75mm to 300mm to working pressure 1380 kPa ductile iron body, non-rising stem, hub, flanged or mechanical joint ends.

		Delete 2.3.5.1 and replace with	Ductile Iron body.
		Add 2.3.6.1.2	Mainline valve boxes shall be MR style.
		Delete 2.3.8.1 and replace with	To AWWA C508: 50 to 300mm diameter to 1200 kPa; 400 to 500mm working pressure to 1035 kPa; ductile iron body, clear waterway type, resilient seated, mechanical joint ends to AWWA C111 of flanged ends to AWWA C110.
2.6	Hydrants	Delete 2.6.2 and replace with	Color: Body shall be painted S/P Urethane Industrial Enamel LF Signal Red General Paint Product # 9811624801. Nozzle caps shall be painted S/P Urethane Industrial Enamel LF White General Paint Product # 9811601001.
3.0	EXECUTION	Append to 3.6.3	Prior to construction, contractor to confirm tie-in location, elevations, pipe materials and dimensions for at least 1.5m upstream and downstream of the tie-in.
3.6	Pipe Installation	Delete 3.6.6 and replace with	Maximum joint deflection shall be 50% of the manufacturer's recommendation.
		Append to 3.6.10.10	Pipe to be installed in accordance with ASTM D2774, and cold bending allowed to a minimum radius of 50 times nominal diameter. All fusing to be completed by personnel trained by the manufacturer.
		Append to 3.6.11	Watermain Identification: yellow PVC marker tape to be placed at top of pipe zone. Marker tape to be continuous, 75mm wide and lettered "Watermain" at 1m intervals.
		Add 3.6.15	Where casing pipes are installed, provide casing spacers at maximum 3.0m spacing with spacers at each bell and 0.5m from the start and end of the casing pipe.

	Add 3.6.16	When joint wrapping is required, all applicable joints shall be wrapped with heat shrink plastic or packed and wrapped with petrolatum tape in accordance to the following standards: .1 ANSI/AWWA C214 (factory applied) .2 ANSI/AWWA C209 (field applied) .3 ANSI/AWWA C217-90 (petrolatum tape) .4 All materials to have zero health hazard. Installation shall be in accordance with the requirements of the Regional Health Engineer under the Health Act.
	Add 3.6.17	Anchor weights to be included on PVC, PVCO and HDPE pipe where the pipe is susceptible to floatation caused by soil and groundwater, with anchor weight sized not to cause settlement.
	Delete 3.10.6 and replace with	Tapings in PVC mains to AWWA C900 pipe to be with service saddles specified in Section 33 11 01 -2.5.3.3. Nuts on service saddle straps to be tightened to torque range specified by manufacturer approved and in no case in excess of that torque. Only manufacturer approved tapping tool will be allowed. Provide test coupons to Contract Administrator.
3.10 Service Connection Installation	Append to 3.10.1	Service connection and boxes shall also be installed in accordance with the City's Water Meter Design Criteria Manual & Supplementary Specifications.
	Append to 3.10.7	Service connections to HDPE mains shall be connected by methods of thermal butt fusion as outlined in ASTM 2657. Butt fusion tees or couplings shall be used for all service connections. Wet tapping HDPE pipe is not permitted for service connections.
	Delete 3.10.11 and replace with	Install and set plumb stop and valveboxes. Adjust top flush with final grade. Leave curb stop or service valves fully closed.

3.19 Testing Procedure

Delete 3.19.2
and replace
with

Before pipe is filled with water, pipe bedding, concreting of all valves and fittings, and backfilling to be completed as required in this specification. Fill each section of pipe and allow to remain full of water for a period of at least 24 hours prior to commencement of any pressure tests. Submit pipeline to a test of 1.5 x working pressure applied at the highest elevation in the each section, with a minimum of 1380 kPa applied at the lowest elevation in the test section. Ensure that test pressure does not exceed pipe or thrust restraint design pressures.

Add 3.19.7

Pressure and leakage testing of high density polyethylene pipe to consist of an initial expansion phase and a test phase. Prior to testing, pressurize the HDPE pipe to test pressure for 4 hours and maintain pressure on an hourly basis to accommodate the initial expansion. Submit pipeline to a test of 1.5 x working pressure applied at highest elevation in each section, with a minimum of 1380 KPa at lowest point of test section, and under no circumstances should the total time with the pipe at 1.5 x working pressure exceed 8 hours.

Immediately upon completion of the initial expansion phase, begin a 2 hour test period. Allowable leakage shall not exceed following:

Normal Pipe Size	Allowable Leakage (L/km)
75mm	18.6
100mm	31.1
150mm	74.5
200mm	124.2
250mm	161.5
300mm	285.6
350mm	335.3

Temperature correction factor to be applied to allowable leakage. Temperature to be taken as temperature of test water in the pipe measured after the initial expansion phase. Temperature correction factor for pressure testing to be:

Temperature (°C)	Correction Factor
23.0	1.0
22.3	0.9
21.0	0.8
19.0	0.7
16.2	0.6
13.0	0.5
9.5	0.4
5.2	0.3
-1.0	0.2

3.20 Disinfection, General Add 3.20.3 Disinfection, flushing and water quality testing shall be completed by the City and only upon successful pre-pressure testing by the Contractor.

3.23 Connections to Existing Mains Delete 3.23.1 and replace with Tie-ins to the existing water mains will be performed by the City, unless noted otherwise in the Contract Documents. The Contractor shall cooperate fully with the City's forces and provide them with suitable working areas and conditions to allow their Work to proceed efficiently. At least 3 weeks notification shall be given to the City's Water Operations Manager before any testing and tie-ins.

Contractor to make all necessary arrangements with Contract Administrator to schedule work to prevent construction delays.

Add 3.23.2 City Crew will complete excavation, tie-in, backfill, compaction and temporary surface restoration for the tie-in works. After tie-ins are complete and temporary surface restored, Contractor shall complete permanent surface restoration, overlays and related maintenance.

END OF SECTION

MMCD Section 33 30 01

Sanitary Sewers

1.0 GENERAL

1.6 Measurement and Payment

Delete 1.6.5 and replace with

Payment for concrete bedding or controlled density fill, where shown on the Contract Drawings, will be made as extra-over payment to sanitary sewer under 1.6.2 of this Section. No payment will be made for concrete bedding or controlled density fill required as a result of unauthorized excavation beyond neat lines or limits of excavation shown on the Contract Drawings.

Add 1.6.8

Payment for casing pipe shall include the method of construction, such as open cut or trenchless technology; excavation and backfill for casing pipe of access pits, casing spacers and end seals. Measurement for casing pipe will be made along the centerline of the casing pipe, over surface, after Work has been completed.

2.0 PRODUCTS

2.1 Concrete Pipe

Add 2.1.5

Interior Lining:

- .1 Concrete pipe, 900mm diameter and larger, shall have continuous interior lining of 2mm thickness or greater.
- .2 Liner shall be one of the following products:
 - .1 Agru Sure Grip Liner – white, grey or yellow high density polyethylene (HDPE) with integral studs, as manufactured by Agru America Inc.
 - .2 Ameron T-Lock – white polyvinyl chloride (PVC) with integral “T-Lock” ribs, as manufactured by Ameron International
- .3 The liner shall be cast directly into pipe at time of manufacturing and cover 360 degrees of the pipe interior and the two edges of the liner shall be welded together, with the weld at the invert of the pipe.
- .4 The liner shall withstand a pull test of at least 100 pounds per linear inch, applied perpendicular to the concrete surface for a period of one (1) minute, without rupture of the locking anchors /ribs or yielding and withdraw from embedment.

- .5 The liner shall be able to withstand a 105 kPa (15 psi) hydrostatic back pressure applied to the under surface of the lining without losing anchorage and without rupture or leakage.

- 2.3 Service Connections**
- Add to 2.3.8.2 Insertable tees are not to be used on 150mm diameter or smaller mainline.
 - Add 2.3.8.4 Saddles with stainless steel straps must be used for connections to existing Asbestos Cement and Vitrified Clay mainlines.

3.0 EXECUTION

- 3.6 Pipe Installation**
- Delete 3.6.6.2 and replace with
 - Add 3.6.14 Where casing pipes are installed, provide casing spacers at maximum 3.0m spacing, including spacers at each bell and within 0.5m from the start and end of the casing pipe.
 - Add 3.6.15 Lined Concrete Pipe, in accordance to 2.1.5 of this Section, shall be installed as follows:
 - .1 The interior liner shall have either: (1) an overlap joint whereby the liner shall protrude 100mm past the spigot end of the pipe to allow a field joint or (2) a butt edge joint whereby the liner shall be terminated 25mm from the ends of the pipe and a 100mm closure strip shall be field welded across the joint, centred to have at least 25mm overlap on each side of the liner.
 - .2 Liner shall not be field welded at the pipe joints until the pipe has been backfilled to within 300mm from the final surface elevation. At no time shall there be more than 150m of installed pipe that has not been field welded and successfully tested.
 - .3 Prior to field welding overlap or butt edge joints, the weld joints shall be clean, free of dirt and water, and roughened using a scraper knife to remove gloss and oxidation.

- .4 Prior to welding the closure strip across butt edge joints, the Contractor shall low pressure air test the installed joint and gasket in accordance with ASTM C1103.
- .5 All field welding persons shall be trained and certified by the manufacturer for the respective liner being used, and have previous proven liner welding experience along with confined space training and certification. Copies of the training certificates shall be provided to the Contract Administrator at least five (5) days prior to construction.
- .6 All field welding shall be completed in accordance with the manufacturer's recommendations, including heat, drying/humidity reduction, and application time adjustments suitable to climate conditions in the pipe at the time of welding.
- .7 At the time of welding, the Contract Administrator may request 400mm long x 200mm wide test weld specimens to complete Quality Assurance of liner pull tests.
- .8 Each transverse welding strip shall be tested. The welding strip shall extend 50mm below the liner to provide a tab for testing. A 10 pound pull test shall be applied to the tab, perpendicular to the face of the pipe, by means of a spring balance and the liner strip shall adhere to the pipe during the test.
- .9 Within three (3) days of the joint being welded, the weld shall be tested with a 20,000 volt electronic holiday detector, as well as physically tested by non-destructive probing through the use of a putty knife.
- .10 All patches over holes, or repairs to the liner, wherever damaged has occurred shall be completed in conformance with the manufacturer's recommendation and tested.
- .11 Defective welds shall be retested after repairs have been made.

Tabs used for testing shall be trimmed away neatly after the welding strip has passed inspections.

3.10 Service Connection Installation

Append to 3.10.3

Plug for temporary blocking of the inlet of inspection chamber shall be removed upon completion of the Work.

Add 3.10.5

After new service connections are installed and transferred to a new sanitary sewer main, old services are to be abandoned including removing the old inspection chamber and capping the old service.

Add 3.10.6

After new service connections are installed and transferred to an existing sanitary sewer main that will remain in operation, the old services are to be abandoned. Abandonment shall include:

- .1 Removal of the old inspection chamber and capping the old service connection pipe at the property line. Drill a 25mm to 37.5mm diameter hole in the end cap to allow for release of air and grouting.
- .2 Chemically grout the old service internally through the sewer main. Grouting records need to be submitted along with a video inspection of the sewer main to confirm the grouting has resulted in a sealed service and that there has been no damage to the existing sewer main nor grout residual on the inside of the existing sewer main.
- .3 If chemical grout cannot be applied then the service can be capped 1.0m from the sewer main and grouted externally.

**3.12 Leakage Testing
General**

Delete 3.12.1
and replace
with

Upon completion of cleaning and flushing of each section, carry out the following testing, which varies by pipe diameter and material type:

- .1 Exfiltration Test or Infiltration Test required for all concrete sanitary sewers 675mm diameter and smaller. Exfiltration Test, per 3.13 of this Section, unless the groundwater table is above the crown of pipe and then Infiltration Test as per 3.15 of this Section.
- .2 Individual Joint Test for all concrete sanitary sewers 750mm diameter and greater.
- .3 If concrete sanitary sewer has interior PVC or HDPE liner, complete liner tests as per 3.6 of this Section.
- .4 Low Pressure Air Test required for all PVC and HDPE sanitary sewers and service connections. Tests on PVC shall be as per 3.14 of this Section. Tests on HDPE shall be as per 3.19.7 of Section 33 11 01, with maximum test pressure of 69 kPa and zero leakage permitted.
- .5 Short Term Deflection Test required for all PVC and HDPE sanitary sewers as per 3.16 of this Section.

**3.14 Low Pressure Air
Test**

Delete 3.14.2
and replace
with

Increase test pressure in section prior to conducting test. Test pressure to be 24 kPa above average groundwater pressure and observe rate of pressure drop.

Delete to
3.14.4 and
replace with

Append the following test periods to the table:

- 150mm – 3 minutes, 12 seconds
- 200mm – 5 minutes, 42 seconds
- 250mm – 8 minutes, 54 seconds
- 300mm – 12 minutes, 50seconds
- 375mm – 20 minutes, 02 seconds
- 450mm – 28 minutes, 51 seconds
- 525mm – 39 minutes, 16 seconds
- 600mm – 51 minutes, 17 seconds
- 675mm – 1 hour, 4 minutes, 54 seconds
- 750mm – 1 hour, 20 minutes, 07 seconds
- 900mm – 1 hour, 45 minutes, 23 seconds

3.16	Short-Term Deflection Test	Delete 3.16.1 and replace with	Lamps test all PVC and HDPE sanitary sewers, unless noted otherwise by the City. Sewers shall be lamped from manhole to manhole to check alignment and grade. Lamping shall be carried out using strong light or mirrors by an approved lamp testing firm. All sewers shall have a minimum 75% pipe diameter exposed when measured horizontally and a minimum 100% pipe diameter exposed when measured vertically when lamped
		Add 3.16.2	For all PVC and HDPE sanitary sewers 600mm diameter and greater, pass rubber test ball, mandrel or test plug having minimum dimension of 95% of base inside diameter of sewer pipe completely through pipes and appurtenances. Test ball, mandrel or test plug shall be collapsible to fit within manhole lid.
3.17	Individual Joint Test	Delete 3.17.1 and replace with	Each joint on pipes 750mm diameter and greater to be joint tested, in accordance with ASTM C1103.
3.18	Video Inspection	Delete 3.18.1 and replace with	The Contractor shall CCTV all installed sanitary sewers and services, regardless of length, material type and diameter, in accordance with Section 33 01 30.1. CCTV to be completed after sewer installation and backfill to the underside of the final surface treatment (i.e. asphalt) and successful passing is a requirement to achieve Substantial Performance.
		Delete 3.18.2 and replace with	In the event the CCTV indicates apparent deficiencies, Contractor shall correct the deficiencies and re-video at the Contractor's expense.
		Add 3.18.3	The City reserves the right to request the sanitary sewers and service connections to be re-videoed during the Maintenance Period. Costs for re-video shall be paid at the unit rates in the Schedule of Quantities and Prices, unless the re-video is required as a result of deficient work.
		Add 3.18.4	The Contractor shall submit the final video and reports to the Contract Administrator, who shall review and submit the reports to the City indicating their acceptance, or non-acceptance, of the system to the City.

**3.19 Installation
Standard**

Delete
3.19.5.2 and
replace with

Mainline sewers and service connections, regardless of pipe material:

- .1 100mm to 250mm diameter, inclusive: 10mm maximum ponding over a 3 metre length of pipeline.
- .2 300mm diameter and larger: 15mm maximum ponding over a 3 metre length of pipeline.

Delete
3.19.5.3 and
replace with

Concrete pipe shall not have cracks exceeding ASTM specifications.

END OF SECTION

MMCD Section 33 34 01

Sewage Force mains

1.0 GENERAL

1.8 Measurement and Payment

Append to 1.8.4

Payment for casing pipe shall include the method of construction, such as open cut or trenchless technology, as noted on the Contract Drawings; and payment shall include excavation and backfill for casing pipe of access pits, casing spacers and end seals. Measurement for casing pipe will be made along the centerline of the casing pipe, over surface, after Work has been completed.

2.0 PRODUCTS

2.2 Pipe, Joints and Fittings

Delete 2.2.1 and replace with

Ductile iron is not permitted.

Delete 2.2.2 and replace with

PVC C900 and PVCO C909 to be manufactured to specifications for pipe size ranges as follows:

- .1 Pipes 150mm to 300mm diameter
- .2 Pipes to be pressure rated to minimum operating pressure of 1620 kPa (235psi)
- .3 Pipes to be certified by Canadian Standards Association to CSA B137.3.1
- .4 Outside diameter to be Cast Iron Pipe Size.
- .5 To be compatible with specified mechanical joint and push-on joint fittings and valves without use of special adapters.
- .6 Joints: Push-on integrally thickened bell and spigot type to ASTM D 3139 with single elastomeric gasket to ASTM F477.

PVC/PVCO not permitted on Arterial Roads, nor are they permitted in areas subject to soil liquefaction in seismic events.

Delete 2.2.5.1 and replace with

Grey Iron (cast iron) fittings are not acceptable.

Delete 2.2.5.10 and replace with

Tie Rods to be in accordance with Section 33 11 01

	Delete 2.2.5.13 and replace with	Joint restraints for PVC / PVC0 forcemains shall be to MMCD and shall not de-rate the pressure rating of the pipe material.
	Delete 2.2.6 and replace with	Pre-stressed Concrete Pressure pipe is not acceptable.
2.3	Valves and Vale Boxes	
	Delete 2.3.2.2 and replace with	To AWWA C515: 400mm and larger to working pressure 1725 kPa, non-rising stem, hub, flanged or mechanical joint ends.
	Delete 2.3.4.1 and replace with	Ductile Iron Body
	Add 2.3.6	Plug Valves to have: .1 Full-port opening not less than 100% of the nominal pipe area. .2 Rating for municipal sewage .3 Minimum rating for operating pressure of 690kpa (100 psi) .4 Valve body and cover: (i) Ductile Iron ASTM A536, grade 65-45-12. .5 Class 125 Flanges to ANSI B16.1 .6 Stainless steel nuts, stud, washers, bolts and stem .7 Seat that is bi-directional welded nickel and corrosion resistant. .8 Side geared valve with actuator
3.0	EXECUTION	
3.6	Pipe Installation	Add 3.6.11 Where casing pipes are installed, provide casing spacers at maximum 3.0m spacing, including spacers at each bell and within 0.5m from the start and end of the casing pipe.

- | | | | |
|-------------|-----------------------------------|--------------------------------|---|
| 3.11 | Pipe Surround | Delete 3.11.5 and replace with | Force main identification: Red or Yellow PVC marker tape to be placed at top of the pipe zone. Marker tape shall be continuous, 75mm wide and lettered permanently with "SEWAGE FORCE MAIN" at 1.0 m intervals along tape. |
| 3.15 | Pressure Testing Procedure | Delete 3.15.2 and replace with | Force main to be submitted to a test of 2.0 x Working pressure applied at highest elevation in each section minimum 690 kPa. Maximum allowable leakage rate at test pressure varies based on pipe material, diameter and length as outlined in 3.15 of this Section. Minimum duration of test period to be 2 hours. |
| 3.17 | Mandrel inspection | Add 3.17.1 | Forcemain to be tested by pigging or passing a mandrel/rubber ball/test plug having 95% of the base inside diameter of the pipe completely through the pipeline A lamp test may not be used in lieu of the ball test. CCTV inspection may be used in lieu of the mandrel inspection. |

END OF SECTION

MMCD Section 33 40 01

Storm Sewers

1.0 GENERAL

1.6 Measurement and Payment

Add 1.6.12

Payment for storm sewers undercrossing services will only be made for crossing with use of a pipe casing as shown on the Contract Drawings or directed by the Contract Administrator. Payment includes the pipe casing and all other work and materials as specified in this Section. Payment will be extra over the storm sewer item under 1.6.2 of this Section for each undercrossing installation.

Payment for casing pipe shall include the method of construction, such as open cut or trenchless technology, as noted on the Contract Drawings; and payment shall include excavation and backfill for casing pipe of access pits, casing spacers and end seals. Measurement for casing pipe will be made along the centerline of the casing pipe, over surface, after Work has been completed.

2.0 PRODUCTS

2.3 PVC Pipe Mainline Profile

Add 2.3.6

Spiral rib PVC profile pipe is not acceptable.

2.3 Spiral Rib Pipe – Steel

Delete 2.5.2 and replace with

Pipe material: Aluminized Steel Type II.

2.6 Service Connections

Add 2.6.8.3

Insertable tee's will only be permitted for new service connections to existing sewers. Manufactured wyes shall be used on all other new storm sewer systems.

Add 2.6.11

All new storm sewer service connections should have an inspection chamber, and the lid shall be PVC pigmented green.

3.0 EXECUTION

3.6 Pipe Installation

Delete 3.6.6 and replace with

Pipe bending is not permitted.

		Add 3.6.14	Where casing pipes are installed, provide casing spacers at maximum 3.0m spacing, including spacers at each bell and within 0.5m from the start and end of the casing pipe.
3.10	Service Connection Installation	Add 3.10.5	All existing functional service connections shall be located and marked, and transferred or connected to the new storm sewer. The Contractor is liable for any damages resulting from service connections being left unconnected.
3.12	Video Inspection	Delete 3.12.1 and replace with	The Contractor shall CCTV inspect all installed storm sewers and services, regardless of length, material type and diameter, in accordance with Section 33 01 30.1. CCTV to be completed after sewer installation and backfill to the underside of the final surface treatment (i.e. asphalt) and successful passing is a requirement to achieve Substantial Performance.
		Delete 3.12.2 and replace with	In the event the CCTV inspection indicates apparent deficiencies, Contractor shall correct the deficiencies and re-video at the Contractor's expense.
		Delete 3.12.3 and replace with	The City reserves the right to request the storm sewers and service connections to be re-videoed video inspected during the Maintenance Period. Costs for re-video shall be paid at the unit rates in the Schedule of Quantities and Prices, unless the re-video is required as a result of deficient work.
		Add 3.12.4	The Contractor shall submit the final video and reports to the Contract Administrator, who shall review and submit the reports to the City indicating their acceptance, or non-acceptance, of the system to the City.
3.13	Installation Standard	Add 3.13.6	Concrete pipe shall not have cracks exceeding ASTM specifications.

END OF SECTION

MMCD Section 33 42 13

Pipe Culverts

2.0 PRODUCTS

2.1 Corrugated Steel Pipe

Delete 2.1.6 and replace with

All Corrugated or Steel Spiral Rib Pipe to be Aluminized Steel Type II to CAN3-G401

2.4 PVC Pipe Profile

Add 2.4.7

Spiral rib PVC profile pipe is not acceptable

2.8 Polypropylene Profile pipe

Add 2.8.1

Polypropylene profile pipe; 300mm to 600mm diameter dual wall to ASTM F2736, 750 to 1500mm diameter triple wall to ASTM F2764. .

Add 2.8.2

Bell and Spigot joints including two rubber gaskets to ASTM3212.

END OF SECTION

MMCD Section 33 44 01

Manholes and Catch Basins

1.0 GENERAL

1.5 Measurement and Payment

Delete 1.5.3 and replace with

Frame and Cover Adjustment shall include: removal of existing frame and cover; cleaning; re-set to meet new grade, profile and cross fall; replace grade rings and one ladder rung to suit.

Minor Manhole Replacement shall include: removal of existing frame and cover; supply and install of a new frame and cover (type to vary based on road classification); provide new grade rings, set at new grade, profile and cross fall. Add one ladder rung to suit.

Major Manhole Replacement shall include: removal of existing cast iron frame and cover, grade rings, concrete lid and one riser section if required; supply and install new concrete riser section, with new frame and cover (type to vary based on road classification), grade rings and set to new grade, profile and cross fall. Add two ladder rungs to suit.

Payment for manhole frame and cover adjustments, and adjustment of existing catch basins, cleanouts, valves, inspection chambers and lawn drains shall be incidental to the asphalt or concrete placement, unless noted otherwise in the Schedule of Quantities and Prices.

Payment for Minor and Major Manhole Replacement shall be on an individual basis, varying by type of frame and cover corresponding to the road classification, unless noted otherwise in the Schedule of Quantities and Prices.

2.0 PRODUCTS

2.1 Materials

Delete 2.1.2 and replace with

Concrete strength shall be minimum 30 MPa, at 28 days, unless otherwise stated.

Delete 2.1.6 and replace with

Manhole lids manufactured from precast concrete shall be rated to withstand H25.

- Delete 2.1.7
and replace
with
- Manhole frame and cover shall be rated to withstand H25 loading. Frame and cover, as shown on Standard Drawings, and as specified in this Section.
- .1 Frame and cover must be made of the following materials:
 1. ASTM A48-03, Class 35B grey cast iron
 2. ASTM A536 Grade 65/45/12 ductile iron
 3. Austempered ductile iron is not permitted
 - .2 Frame and cover must be from the same foundry, and imprinted with foundry name, date code and country of origin.
 - .3 Be height-adjustable to suit the road surface contour by means of integral levelling screws or flanged frame with telescopic extension, as shown on the Standard Drawings, and with exception for manholes on local roads:
 1. Levelling screws shall be integrally designed with the frame and cover
 2. Flanged frame with telescopic extension design shall be resilient seated
 3. Use of shims, wedges, or any materials that will induce point load to the concrete lid or grade ring is not permitted
 - .4 Any frame and cover assembly creating a point load on the concrete riser rings will not be permitted.
 - .5 Manhole cover shall have a diameter between 625mm and 660mm, as 565mm diameter cover is not permitted, and weight between 60kg and 70kg.
 - .6 Bolt down manhole cover is not permitted unless approved by the Contract Administrator.
- Delete 2.1.16
and replace
with
- Adjusting grade rings to be as follows:
- .1 Concrete to ASTM C478M, with a minimum thickness of 75mm and maximum thickness of 150mm. Concrete grade rings are only permitted on local roads.

.2 HDPE to ASTM D1248 and rated for H25 loading. To be free of cracks, voids, and other defects. Maximum of three grade rings is permitted.

.3 Expanded Polypropylene (EPP) rated to H25 loading, and free of cracks, voids, and other defects. Maximum of three grade rings is permitted.

Delete 2.1.17 and replace with Concrete bricks are not permitted.

Delete 2.1.23 and replace with Pre-fabricated Corrugated Steel Pipe Manholes are not permitted.

Add 2.1.24 Anchor bolts, hex nuts and washers to be as follows:

- .1 Anchor bolts minimum 5/8 inch diameter and to ASTM 307 Grade C, and hot dip galvanized.
- .2 Hex bolts to ASTM A563 Grade A.
- .3 Washers to ASTM F844 Grade A.

Add 2.1.25 Sealant: Sealant between manhole risers, and between grade rings and casting, shall be hydrophobic polyurethane sealant and adhesive.

Add 2.1.26 In areas where groundwater table is above pipe invert, manholes to be sealed watertight at all pipe connections with epoxy gel or polyurethane product to ASTM D 1850.

3.0 EXECUTION

3.3 Manhole Installation

Delete 3.3.12.2 and replace with For local roads only, allowable product is: cast-in-place form system; or pre-cast concrete grade rings as per 2.1.16 of this Section.

Delete 3.3.12.5 and replace with Proper layer of grout between the grade rings and spacers, covering the entire surface of the rings, should be utilized.

Append to 3.3.13.6	<p>Set height adjustable frame in direct contact and centered on non-concrete grade rings, and secure frame and adjustment rings to manhole lid by pre-set anchor bolts for new installation or Hilti bolt for rehabilitation. Anchor bolts, hex nuts and washer to be as per 2.1.24 of this Section.</p> <p>In case where the existing road grade exceeds 8%, taper riser rings shall be used in conjunction with the height adjustable manhole to supplement the additional inclination.</p>
Append to 3.3.13.7	<p>For leveling screw style height adjustable manhole frame and cover, 30MPa concrete with 10mm aggregate shall be used to infill void space between the leveling screws.</p>
Delete 3.3.13.8 and replace with	<p>Watertight sealant to fill gap between frame and adjustment ring, and between adjustment ring and concrete lid.</p>
Append to 3.3.17	<p>Prior to paving the base lift, Contractor shall confirm the accuracy of the base gravel preparation, pavement contours, and appurtenance adjustments. Road grade and elevations shall be verified with string line or other method to ensure the cover match the grade and cross fall of the road.</p> <p>Final cover grade shall be set within 3mm from the surrounding road surface. The Contractor Administrator reserves the right to request the Contractor to repair the manhole and the pavement should the manhole settle more than 5mm from the surrounding road surface within the Maintenance Period.</p>
Delete 3.3.18 and replace with	<p>Pre-fabricated Corrugated Steel Pipe Manholes are not permitted.</p>

END OF SECTION

MMCD Section 34 41 13		Traffic Signals	
1.0	GENERAL		
1.4	Electrical Energy Supply	Add 1.4.4	The <i>Contractor</i> shall coil and tape conductors out of weatherhead. Utility company shall complete electrical service connections.
1.9	Measurement and Payment	Append to 1.9.1	Payment shall include excavation, disposal of surplus excavated material, bedding, supply and installation of all pipe and materials, concrete encasement, import or native backfill as shown on the <i>Contract Drawings</i> , and all surface restoration.
2.0	PRODUCTS		
2.1	General	Delete 2.1.2 and replace with	All products supplied to be new, and in accordance with <i>Contract Documents</i> . All products must bear evidence of either a mark or a label of a certification agency accredited by the Standards Council of Canada or an approved label issued by the BC Safety Authority.
		Delete 2.1.3 and replace with	All products shall be in accordance with Section 01 62 01S, and where the product is not listed in this Section then <i>Contractor</i> to contact the <i>Contract Administrator</i> for a current list.
2.4	Plastic Junction Boxes	Append to 2.4.1	Plastic junction box lid to be galvanized.
2.5	Concrete Junction Boxes	Delete 2.5 and replace with 2.5.1	Refer to Drawing SSD-R.E.6 and –R.E.7 for concrete junction box details.
2.6	Poles and Anchor Bolts	Append to 2.6.1	Traffic Signal poles shall be Type S or L Shafts as defined on the <i>Contract Drawings</i> . Traffic pole specifications vary by neighbourhoods and the latest specifications are available from the City of Surrey.
2.7	Conductors and Cables	Add 2.7.5	For Roadway Lighting conductors refer to Supplemental Specifications Section 26 56 01.
		Add 2.7.6	Shielded cables for emergency vehicle pre-emption system shall be “GTT Opticom Cable, model 138” and no alternates are permitted unless noted otherwise.

2.9	Conductors Connectors	Add 2.9.1.3	For Roadway Lighting conductor connectors refer to Section 26 56 01.	
2.11	Service Panels	Delete 2.11.1 and replace with	Service panels shall be as shown on Contract Drawings.	
2.16	Traffic and Pedestrian Signals	Append to 2.16.1	Traffic signal heads and pedestrian signal heads shall be aluminum. Each primary signal and special crosswalk head section shall be designed for a 300mm diameter LED display and have a matching cowl visor. Each secondary signal head section shall be designed for a 300mm diameter LED display and shall have a 300mm long tunnel visor. Each pedestrian signal head shall be designed for a 450mm bi-modal LED display with countdown. All signal heads shall have yellow aluminum backboards with 75mm border of yellow prismatic retro-reflective sheeting (3M™ Scotchlite™ Diamond Grade™ VIP, Series 3990).	Apr. 2020
		Delete 2.16.2 and replace with	Traffic and pedestrian signal head housing shall be green. Special crosswalk head housing shall be yellow.	Apr. 2020
		Add 2.16.3	Fire signal heads shall have special yellow backboards as shown on Drawing SSD-R.E.9.	
2.21	Pedestrian / Cyclist Pushbuttons	Append to 2.21.1	All pedestrian pushbuttons shall be Accessible Pedestrian Signal (APS) type with the exception of special crosswalk signals. Special crosswalk and cyclist pushbuttons shall have audible and visual actuation indicators.	Apr. 2020
		Delete 2.21.8 and replace with	Cyclist pushbuttons shall have white background and black raised characters.	
2.22	Luminaires	Delete 2.22 and replace with	All luminaires shall be LED. Refer to Section 26 56 01.	Apr. 2020
2.26	NEMA Traffic Controllers	Delete 2.26 and replace with	NEMA Controllers are not permitted.	
2.29	Illuminated Crosswalk Signs	Add 2.29.2	Crosswalk internal illumination and downlight shall be LED	

2.34	Advance Warning Signs	Add 2.34.1	Advance warning signs shall have illustration details in yellow prismatic retro-reflective sheeting (3M™ Scotchlite™ Diamond Grade™ VIP, Series 3990. Signal heads shall be 300mm green aluminum with yellow LED and cowl visors.
3.0	EXECUTION		
3.1	General	Add 3.1.5	When tying into or upgrading an existing installation, maintain the existing traffic signal operation at all times.
3.3	Concrete Bases	Append to 3.3.1	Refer to Drawing SSD-R.E.5 for controller base details.
3.4	Junction Boxes and Vaults	Append to 3.4.1	All conduits shall enter the box through knockouts in the side as opposed to the bottom
3.5	Underground Conduit	Append to 3.5.1	The conduit shall not be bent in the field by deflecting joints. Only factory bends will be accepted
		Delete 3.5.2 and replace with	Minimum cover over conduits to be 600mm in boulevard areas and 900mm in travelled areas.
		Delete 3.5.5 and replace with	Before pulling conductor cable/wire into a run of conduit, the conduit shall be blown out with compressed air, and pull string installed with caps at each end. Conductors shall be pulled in slowly by hand or hand winch, in order to keep close control on pulling tension and prevent cutting the conduit at bends.
3.6	Poles and Related Equipment	Delete 3.6.7 and replace with	Field Drilling of holes larger than 33mm diameter not allowed in Type 1, 3, 6, 7, L & S shafts, and all arms and extension. Where larger holes are required, reinforce holes with welded bushing prior to galvanizing.
		Append to 3.6.9	Poles shall be erected plumb, using the shims supplied if required. No more than 4 shims shall be used for any one bolt. If pole can't be installed with 4 shims of less than foundation shall be adjusted. After traffic signal poles are installed, there shall be at least one thread of the anchor bolts exposed on top of all nuts.

3.7 Traffic and Pedestrian Signal Head Mounting	Append to 3.7.4	Traffic signal head lenses and pedestrian signal head lenses shall be cleaned prior to signal start-up.
	Add 3.7.5	Primary traffic signal heads shall be mounted to pole arms as per Standard Drawings. Primary traffic signal heads shall be safety cabled to the pole arm using 3/32" galvanized steel aircraft cable looped through the traffic signal backboard and fastened with a rope clip (VAN-RC18 or approved alternate).
	Add 3.7.6	Secondary traffic signal head and pedestrian head mounting brackets and hardware shall be installed as per Standard Detail Drawing E5.2. Traffic signal poles shall be drilled such that all wiring shall be located within the poles and traffic signal brackets.
3.10 Luminaires and Photocells	Add 3.7.7	Secondary and Pedestrian signal head mounting arms at skewed intersections are to be drilled in the field in order to achieve optimum viewing angles.
	Delete 3.10.2 and replace with	Luminaires shall be securely fastened to the poles, leveled and cleaned after pole erection and plumbing is complete.
	Add 3.10.4	NEMA wattage label must be visible at the bottom of the luminaire on all cobra head style fixtures.
3.13 Electrical Service Panels	Add 3.13.2	The electrical service panel shall be installed a minimum of 2.5m from the traffic controller.
3.14 Wiring	Add 3.14.14	Looping of feeder conductors with "T" taps shall not be permitted.
3.16 Traffic Controller	Add 3.16.8	Duct-seal shall be placed over/in all underground conduits entering traffic signal cabinet. All unused conduits shall be capped with an R.PVC cap, and cap not to be glued.
	Add 3.16.9	Surrey will supply two (2) traffic signal cabinet padlocks and one (1) electrical service panel padlock. Contractor to install.
	Add 3.16.10	Traffic signal cabinet interior must be kept dry during inclement weather.

3.17	Detector Loops	Delete 3.17.1 and replace with	Detector loops shall be as per Drawing SSD-R.E.12 and installed per Standard Detail Drawings E8.1 to E8.7.
		Delete 3.17.2 and replace with	Detector loop shall be installed in the base lift of asphalt when possible. Loops in adjacent lanes shall be wound in opposite directions, i.e.; clockwise, counter clockwise, clockwise, etc.
		Add 3.17.3	Each shielded cable shall run continuously with no splices from the traffic signal cabinet to the junction box. Splices between the detector loop and the shielded cable shall be connected with solder less type connectors and dipped in 3M ScotchKote™.
3.19	Advance Warning Signs	Add 3.19.2	Advance warning signs shall be completely covered with burlap sack until system start-up.
3.20	Grounding & Bonding	Add 3.20.5	No grounding rod or plate electrodes shall be installed inside the traffic signal cabinet base.
3.22	Pole Application Finish	Append to 3.22.1	Poles shall powder coated and in accordance with section 26 56 01. Pole color shall be as per City Specifications for each neighbourhood.
		Append to 3.22.4	Contractor shall clean and wire brush galvanized surfaces, touch up scratches and abrasions with prime coat (General Paint META Prime, vinyl wash), and apply finish coat of non-alkyds color base paint. Poles must be free from moisture (rain, dew, frost, fog). No pole refinishing shall be undertaken if frost is predicted within 24 hours of the work.
3.28	Emergency Vehicle Pre-emption	Add 3.28.1	The Contractor shall install, as noted on Contract Drawings, emergency vehicle pre-emption (Opticom) infrared receiver units on signal pole arms as per manufacturer's instructions. The Contractor shall provide aiming, testing and commissioning of this equipment required for correct operation.
		Add 3.28.2	Opticom receiver units shall be supplied by the City.
3.29	Streetname Signs	Add 3.29.1	Streetname signs to be installed as per Drawing SSD-R.E.8, and safety cabled to the pole arm using 3/32" galvanized steel aircraft cable looped through the street name sign and fastened with a rope clip.

END OF SECTION



Engineering Department

**Supplementary Master
Municipal Construction Documents**

**SUPPLEMENTARY STANDARD
DRAWINGS**

April 2020

The City of Surrey Supplementary Master Municipal Construction Documents are supplemental to the **Master Municipal Construction Document – Platinum Edition (2009)** and take precedence over the MMCD General Conditions, Specifications, Standard Detail Drawings and their Amendments.

The following table serves as amendments to the **Master Municipal Construction Document – 2009 Edition (Platinum Book)** which have been adopted by the City of Surrey (“City”) and are to be included within the City’s Supplementary Specifications.

MMCD Drawing	Amendment / Supplementary Drawing
Drawings CE 1.3, CE 1.4, CE 1.5 and CE 1.7	References to Drawing E 8.3 should be changed to E 7.3 for conduit layout
Drawing E 5.7	References to Drawing E 6.8 should be changed to E 5.8
Drawings E 7.2 and CE 7.3	Delete references to Drawings A 8.2 and A 8.3
Drawings E 7.5 and CE 7.6	References to Drawing E 8.10 should be changed to E 7.10 for ground plate detail
Drawing E 7.7	References to Drawing E 8.8 should be changed to E 7.8 for ground plate detail
Drawing S6	Flow direction is incorrect and should be pointing to the right

The City has developed Supplementary Standard Drawings (SSD’s) which supplement, and where applicable overwrite, the Standard Detail Drawings within the MMCD (2009). A list of the City’s SSD’s and a concordance table with references to the MMCD Standard Detail Drawings is included at the end of the Supplementary Specifications.

Drawing Table of Contents

DRAWING NUMBER	DRAWING TITLE
GENERAL	
SSD-G.1	Lot Service Connections
SSD-G.1.1 (Replace MMCD SDD-S9)	Inspection Chamber for Sanitary and Storm Sewer Connections
SSD-G.2	Regular Trench Cuts
SSD-G.3	Irregular & Diagonal Cuts
SSD-G.4 (Replace MMCD SDD-G4)	Utility Trench
SSD-G.5 (Replace MMCD SDD-G5)	Surface Asphalt Reinstatement and Standard Road Structure Sections
SSD-G.6	Type I & II Height Adjustable Manhole Frame and Cover
DRAINAGE	
SSD-D.1	Side Slopes for Detention Ponds
SSD-D.2	Detention Basin Plan View
SSD-D.3	Flow Control Manhole "A" (Detention Pond)
SSD-D.4	Flow Control Manhole "B" (Detention Pond)
SSD-D.5	Oil / Grease Separator
SSD-D.6	Top Inlet Catch Basin Grate and Frame
SSD-D.7	Boulevard Basin Grate
SSD-D.8	Asphalt Aprons for Catch Basins
SSD-D.9	Bike Friendly Catch Basin and Curb
SSD-D.9.1	Offset Sump Catch Basin
SSD-D.10	Commercial Driveway Sump
SSD-D.11	Timber Headwall Details for use only in Lowlands
SSD-D.12	Subdrain

Apr. 2020

Apr. 2020

Apr. 2020

Apr. 2020

Apr. 2020

SANITARY	
SSD-S.1	Sanitary Sewer Service Lead at Property
SSD-S.2	Manhole Benching Details
SSD-S.2.1	Manhole Frames and Cover
SSD-S.3	Private Pump System Configuration up to 75mm
SSD-S.3.1	Cleanout Manhole for Low Pressure Sewers
SSD-S.3.2	Typical Low Pressure Sewer Connection Property Line Chamber, 100mm and Larger Service
SSD-S.4	Service Connection P-Trap Private Property
SSD-S.5	Manhole for Pressure Sewers
SSD-S.6	Typical Forcemain Connection Wet Tap Coring
TRANSPORTATION	
SSD-R.1	Road Sections, Arterial Roads
SSD-R.2	Road Sections, Collector Roads
SSD-R.3	Road Sections, Local Roads
SSD-R.4	Road Sections, Urban Forest Arterial Roads
SSD-R.5	Road Sections, Urban Forest
SSD-R.6	Road Sections, Historical
SSD-R.7	Road Sections, Half Road
SSD-R.8	Road Sections, Rural Roads
SSD-R.9	Road Sections, Rural Half Road
SSD-R.10	Road Drainage for Roads Without Curbs
SSD-R.11	Frontage Roads, Typical Collector Road Access
SSD-R.11.1	Frontage Roads Typical Interim Access

Apr. 2020

Apr. 2020

Apr. 2020

Apr. 2020

Apr. 2020

SSD-R.11.2	Road Sections, Frontage Road	
SSD-R.12	Lane Section, Standard	Apr. 2020
SSD-R.12.1	Lane, Green & Urban	
SSD-R.13	Turnaround, Cul-De-Sac Bulb	
SSD-R.13.1	Cul-De-Sac, Offset	
SSD-R.14	Turnaround Hammerhead	
SSD-R.15	Raised Median, Left Turn Bay	Apr. 2020
SSD-R.15.1	Raised Median, End Treatment	Apr. 2020
SSD-R.15.2	Raised Median, Bull Nose End Barrier CurbDetail	
SSD-R.15.3	Raised Median, Bull Nose End Extruded CurbDetail	
SSD-R.16	Median Planting Section	
SSD-R.17	Raised Median, Fence	Apr. 2020
SSD-R.18	Bus Stop, Bay Details	Apr. 2020
SSD-R.18.1	Bus Stop, Landing Pad	Apr. 2020
SSD-R.18.2	Bus Stop, Bus Shelter Pad Details	
SSD-R.19	Guard Rail	
SSD-R.19.1	Guard Rail – Assembly & Mounting	
SSD-R.20	Walkways, Engineering or Emergency Access	
SSD-R.20.1	Walkways, Baffle Gate	
SSD-R.21	Pathways, Next-to-Road Multi-Use Detail	Apr. 2020
SSD-R.21.1	Pathways, Multi-Use Section Details	Apr. 2020
SSD-R.21.2	Pathways, Median Mid Block Crossing Detail	
SSD-R.22	Pathways, Locking Bollard	
SSD-R.23	Driveways, Locations & Spacing	

SSD-R.24	Driveways, Single Family Residential Letdown
SSD-R.24.1	Driveways, Multi-Family / Commercial / Industrial Letdown
SSD-R.24.2	Driveways, Crossing for Rollover Curbs Details
SSD-R.24.3	Driveway Letdowns, Cross Section
SSD-R.25	Driveways, Curb Return Crossing
SSD-R.26	Split Letdown at Intersection. Boulevard Greater than 4.50m
SSD-R.26.1	Split Letdown at Intersection. Boulevard 3.00-4.49m
SSD-R.26.2	Single Ramp Letdown with Parallel Scoring
SSD-R.26.3	Single Letdown at Intersection. Boulevard Less than 2.99m
SSD-R.27	Sidewalks, Interim Asphalt
SSD-R.28	Traffic Calming, Speed Hump and Table
SSD-R.28.1	Traffic Calming, Raised Intersection Details
SSD-R.28.2	Traffic Calming, Typical Raised Median
SSD-R.28.3	Traffic Calming, Curb Extensions and On-Street Parking Bay
SSD-R.29	Traffic Calming, Traffic Circle
SSD-R.29.1	Traffic Control, Centre Island Detail
SSD-R.29.2	Traffic Control, Splitter Island Details
SSD-R.30	Traffic Control, Traffic Button
SSD-R.31	Traffic Control, Roundabout
SSD-R.32	Concrete Steps Without Footing – with Bicycle Ramp
SSD-R.33	Security Chain-Link Fence – Gates
SSD-R.34	Decorative Fence
SSD-R.35	Raised Median, Maintenance Pad
SSD-R.36	Swing Gate Details

TRANSPORTATION - ELECTRICAL		
SSD-R.E.1	Type D2 Concrete Base for 13.5m Davit Pole Precast	
SSD-R.E.2	Precast Type D2 Concrete Base for 13.5m Davit Pole	
SSD-R.E.3 (Replace MMCD SDD-E4.1)	Type 2 Shaft Installation Details for 13.5m Davit Pole	
SSD-R.E.4 (Replace MMCD SDD-E4.2)	Type 2 Shaft Pole Assembly for 13.5m Davit Pole	
SSD-R.E.5 (Replace MMCD SDD-E1.5)	Model 332 Traffic Signal Cabinet Installation	
SSD-R.E.6	Type 1, 2, and 3 Junction Box Details Concrete	
SSD-R.E.7	Type 5 Junction Box Details (Concrete)	
SSD-R.E.8	Street Name Sign Mounting Details	
SSD-R.E.9	Fire Signal Signs	
SSD-R.E.10	Phasing Diagram For 8-Phase Controller	
SSD-R.E.11	332 Controller Cabinet Typical Loop, Pre-Emption and Pedestrian Assignments	
SSD-R.E.12	Typical Detector Loop Locations	
SSD-R.E.13 (Replace MMCD SDD-E7.1)	Luminaire Wiring in Pole Hand Hole	
COMMUNICATION NETWORK		
SSD-E.10.11	Communication Conduit Valves	Apr. 2020
SSD-E.10.12	Communication Conduit Utility Trench	Apr. 2020
SSD-E.10.13	Communication Conduit Conduit Entry Detail	Apr. 2020
WATER		
SSD-W.1 (Replace MMCD SDD-W2a)	Water Service Connection 19mm to 50mm Only	Apr. 2020
SSD-W.2	Fireline / Domestic Service Connection Greater Than or Equal to 100mm	Apr. 2020

SSD-W.3	50mm Pressure Sustaining Valve & Chamber Installation	Apr. 2020
SSD-W.4 (Replace MMCD SDD-W8)	Blow-Off Chamber	
SSD-W.5 (Replace MMCD SDD-W9)	Blow Down Chamber	
SSD-W.6	Combination Air Valve	Apr. 2020
UNIQUE AREAS		
SSD-U.1.1	Bridgeview / South Westminster Area	
SSD-U.1.2	Typical Section, Road Without Curb Bridgeview & South Westminster	
SSD-U.1.3	Residential Driveway Crossing Bridgeview & South Westminster	
SSD-U.1.4	Driveway for Roads Without Curbs & Swale Bridgeview & South Westminster	
SSD-U.2	West Panorama Ridge Area	
SSD-U.2.1	Ditch Crossing, West Panorama Ridge	
SSD-U.2.2	Typical Road Sections, West Panorama Ridge	
SSD-U.3	Surrey City Centre Area	
SSD-U.4	Central Semiahmoo Area	
SSD-U.4.1	Limited Local Road Section, Central Semiahmoo	
SSD-U.4.2	Local Through Road Section, Central Semiahmoo	
SSD-U.4.3	Limited or Through Collector Road Section, Central Semiahmoo	
CITY CENTRE		
CCSD-1	Boundary Delineation Map	
CCSD-2A	Road Classification Map	
CCSD-2B	Road ROW Width Map	
CCSD-2C	Streetlight Type Map	
CCSD-3	Street – Tree Type Map	
CCSD-4	Separated Cycling Paths	
CCSD-5A	Typical Arterial Road Cross Section (32m) ROW	Apr. 2020
CCSD-5B	Protected Bike Lane Plan View (32m) ROW	Apr. 2020
CCSD-5C	Protected Bike Lane Cross Section (32m) ROW	Apr. 2020

CCSD-5D	Protected Bike Lane Intersection Plan View – 32m ROW	Apr. 2020
CCSD-6A	Typical Arterial Road Cross Section (30m) ROW	Apr. 2020
CCSD-6B	Protected Bike Lane Plan View (30m) ROW	Apr. 2020
CCSD-6C	Protected Bike Lane Cross Section (30m) ROW	Apr. 2020
CCSD-6D	Protected Bike Lane Intersection Plan (30m) ROW	Apr. 2020
CCSD-7A	Typical Collector Road Cross Section (24m) ROW	Apr. 2020
CCSD-7B	Protected Bike Lane Plan View (24m) ROW	Apr. 2020
CCSD-7C	Protected Bike Lane Cross Section (24m) ROW	Apr. 2020
CCSD-7D	Protected Bike Lane Intersection Plan View (24m) ROW	Apr. 2020
CCSD-8A	Typical Local Road Cross Section	Apr. 2020
CCSD-8B	Local Boulevard for (20m) ROW Hardscape Frontage	Apr. 2020
CCSD-8C	Local Boulevard for (20m) ROW Boulevard Treatment Plan & Section	Apr. 2020
CCSD-8D	Local Boulevard for (20m) ROW Typical Hardscape Section (4.5m) Boulevard	Apr. 2020
CCSD-8E	Local Boulevard for (20m) ROW Softscape Frontage	Apr. 2020
CCSD-8F	Local Boulevard for (20m) ROW Typical Softscape Section (4.5m) Boulevard	Apr. 2020
CCSD-9A	Typical Cross Section Green Lanes (6.5m) Pavement	Apr. 2020
CCSD-9B	Typical Cross Section Green Lanes (8.0m) Pavement	Apr. 2020
CCSD-10A	BC Parkway with Hardscape Boulevard	Apr. 2020
CCSD-10B	BC Parkway with Hardscape Boulevard – Cross Section	Apr. 2020
CCSD-10C	BC Parkway with Softscape	Apr. 2020
CCSD-10D	BC Parkway with Softscape - Cross Section	Apr. 2020
CCSD-11A	Single Letdown at Intersection Boulevard	Apr. 2020
CCSD-11B	Split Letdown at Intersection Boulevard Greater than 4.50m	Apr. 2020
CCSD-11C	Single Ramp Letdown with Parallel Scoring	Apr. 2020
CCSD-11D	Typical Treatment Two Letdowns for Protected Intersection	Apr. 2020
CCSD-12A	Driveway Type I Plan & Section View (30m) ROW	Apr. 2020
CCSD-12B	Driveway Type II Plan & Section View (30m) ROW	Apr. 2020
CCSD-12C	Local Road Driveways	Apr. 2020
CCSD-13A	Typical Bus Stop Plan View (30m) ROW	Apr. 2020
CCSD-13B	Local Boulevard for 20m ROW Bus Stop for (4.5m) Frontage	Apr. 2020
CCSD-14A	Street Lights – Type ‘A’	Apr. 2020
CCSD-14B	Street Lights – Type ‘B’ with Pedestrian Light	Apr. 2020
CCSD-14C	Street Lights – Type ‘C’ Pedestrian Light	Apr. 2020
CCSD-14D	Traffic Signal Pole	Apr. 2020
CCSD-14E	Typical Trash Can (Big Belly)	Apr. 2020

CCSD-14F	Typical Bike Rack (BR1)	Apr. 2020
CCSD-14G	Bench Detail	Apr. 2020
CCDS-15	Ornamental Grasses	Apr. 2020

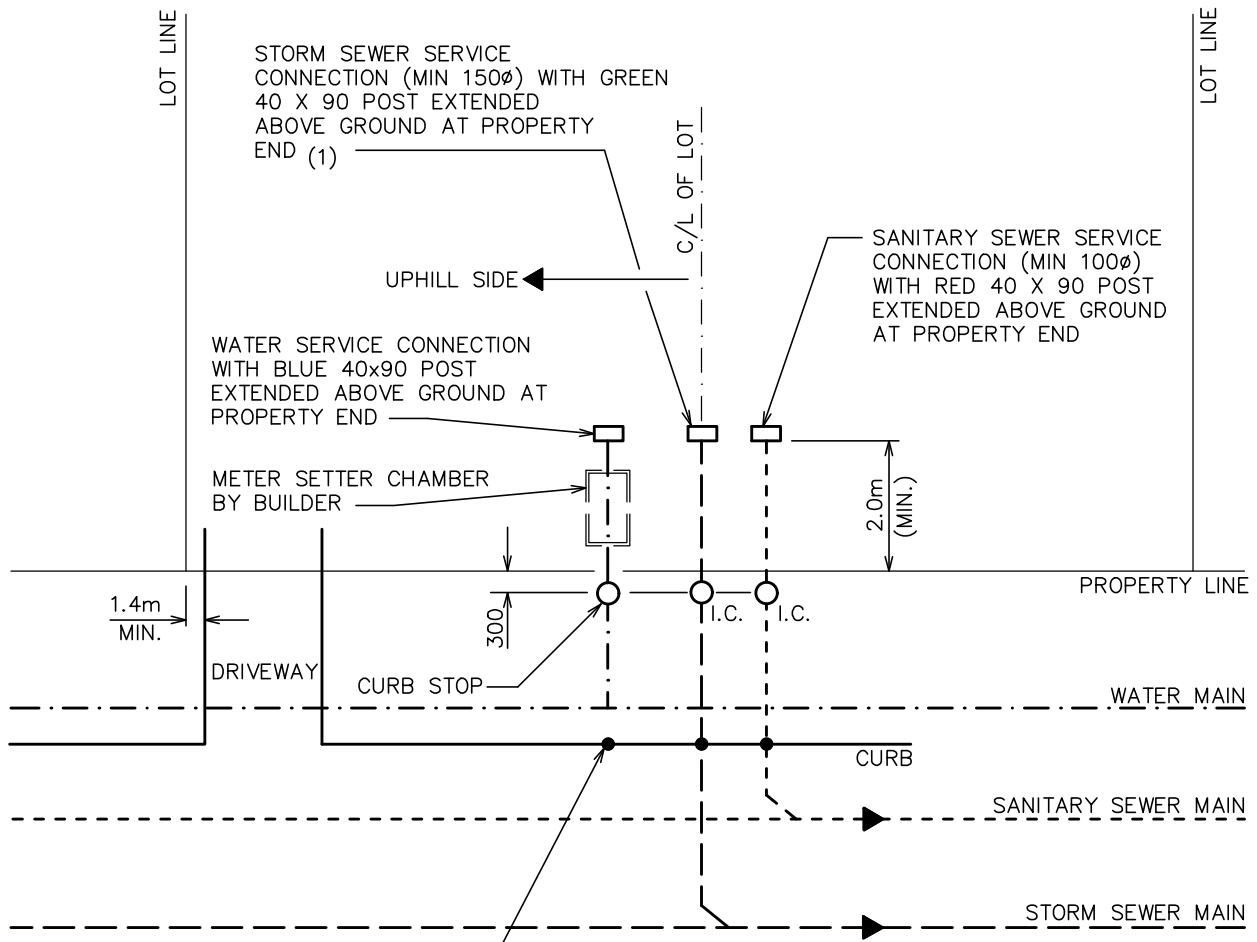

FACE OF CURB TO BE NOTCHED AND STAMPED WITH THE LETTER "W", "S", & "D" FOR WATER, SANITARY AND STORM SERVICE CONNECTION RESPECTIVELY. PAINT SERVICE COLOUR (TYPICAL) (2)

NOTES:

- (1) STORM SEWER SERVICE CONNECTION MAY ALTERNATIVELY BE 300 FROM THE SIDE PROPERTY LINE ON THE LOWER END OF THE GENERAL GRADE OF THE AREA.
- (2) ALL CONNECTIONS SHALL BE LOCATED AT LEAST 1.5m FROM THE DRIVEWAY AND THE SERVICE LINES FOR THE HYDRO POWER LINE, B.C. TEL AND OTHER UTILITIES. EXEMPTION MAY BE ALLOWED IN CUL-DE-SACS SUBJECT TO THE APPROVAL OF THE CITY OF SURREY.

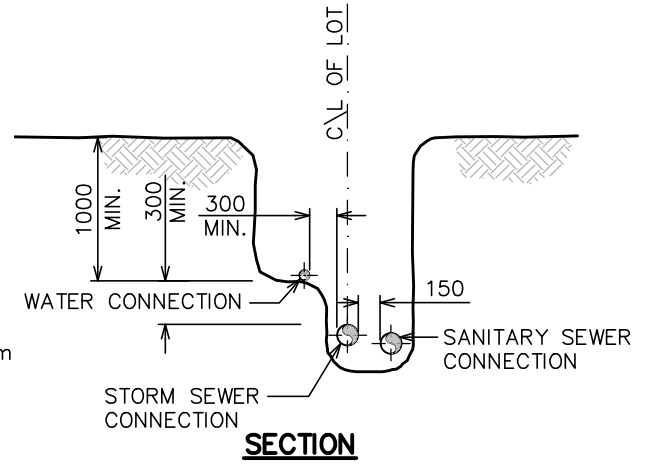

3		
2	APRIL 2020	SCOTT NEUMAN
1	JANUARY 2016	SCOTT NEUMAN
	Revision Date	Approved

All Dimensions Shown In Millimetres, Unless Otherwise Noted

Title **LOT SERVICE CONNECTIONS**



Approved By : *[Signature]*
 APRIL 2020 G.M. Engineering

DRAWING NUMBER
SSD-G.1

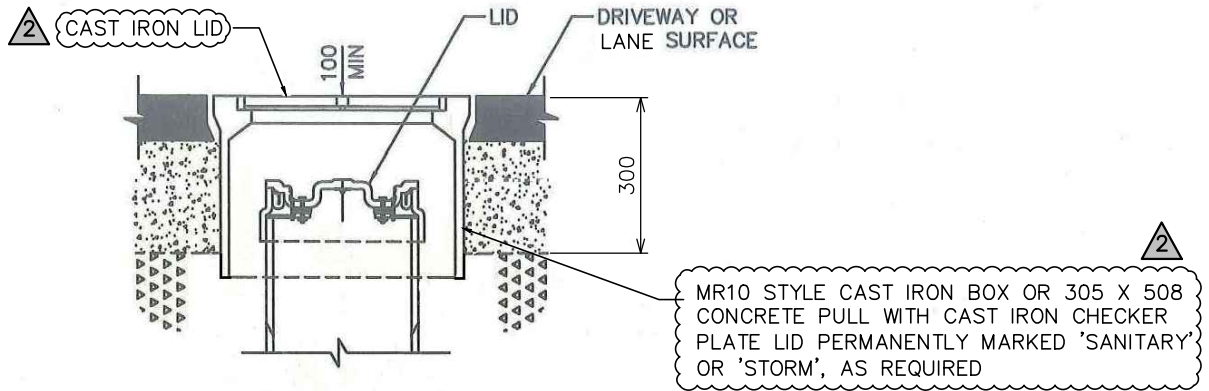
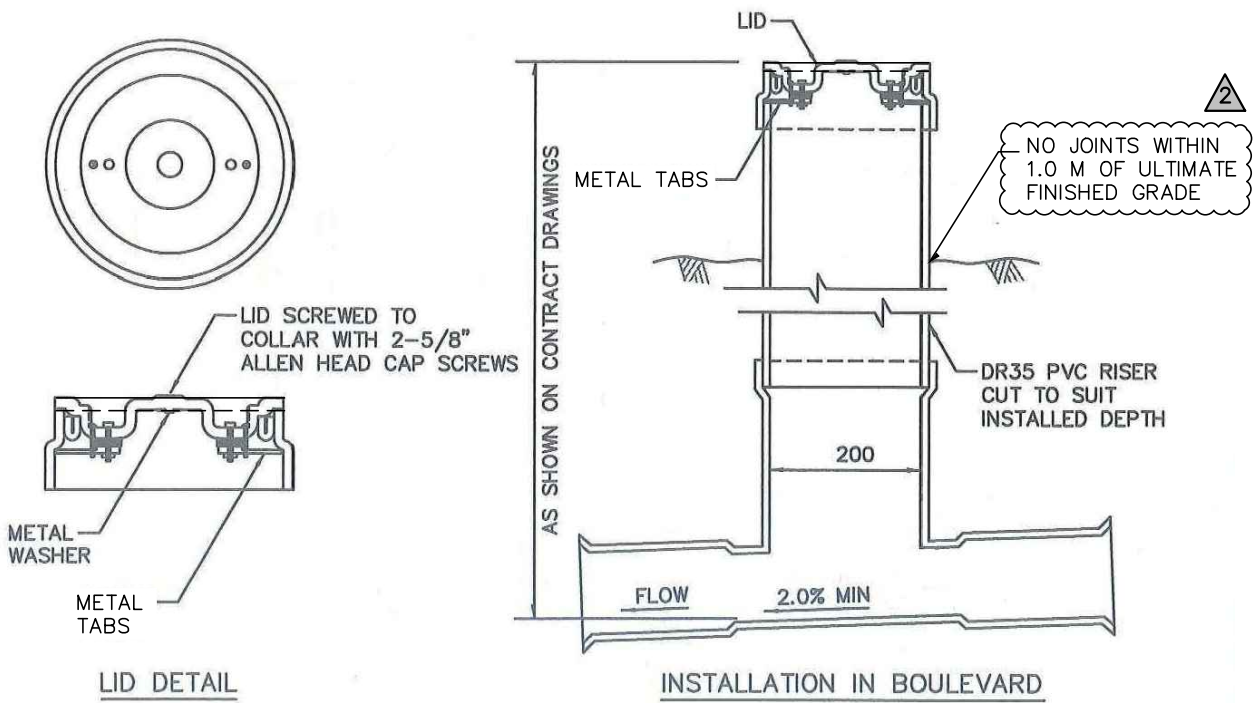

INSTALLATION IN DRIVEWAY OR SIDEWALK⁽⁴⁾

1. REFER TO DRAWING S7 AND S8 FOR INSTALLATION REQUIREMENTS.
2. INSPECTION CHAMBER TO BE APPROVED MANUFACTURED FITTING.
3. REFER TO CONTRACT DRAWINGS FOR SITE SPECIFIC DIMENSIONS. REFER TO SECTION 33 30 01 AND 33 40 01 FOR DETAILED SPECIFICATIONS.

4. MR10 STYLE CAST IRON BOX REQUIRED WHEN INSPECTION CHAMBER IS IN A ROAD OR WITHIN 2.0m OF A DRIVEWAY OR LANE. MARKED "SANITARY OR STORM" AS APPLICABLE. MR10 STYLE ONLY FOR COMMERCIAL AND INDUSTRIAL AREAS.

3			All Dimensions Shown In Metres, Unless Otherwise Noted
2	APRIL 2020	SCOTT NEUMAN	
1	JULY 2016	SCOTT NEUMAN	Title INSPECTION CHAMBER FOR SANITARY AND STORM SEWER CONNECTIONS
	Revision Date	Approved	
SURREY <small>the future lives here.</small>			Approved By : APRIL 2020 G.M. Engineering
SUPPLEMENTARY STANDARD DRAWINGS			

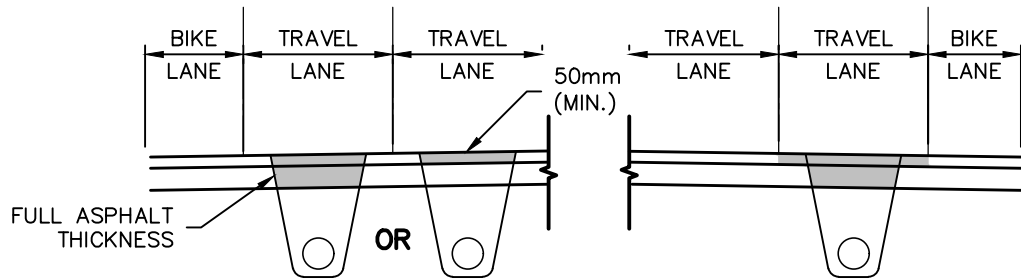

TEMPORARY RESTORATION

PERMANENT RESTORATION

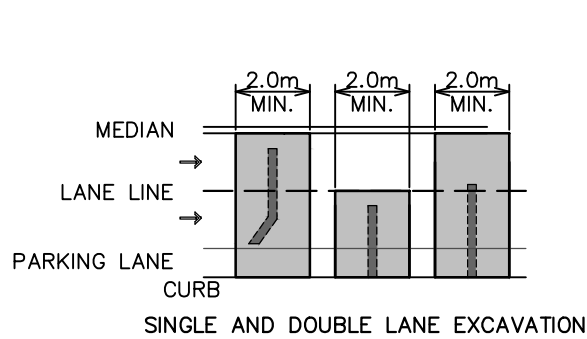

**PERPENDICULAR CUTS
(PERMANENT RESTORATION)**

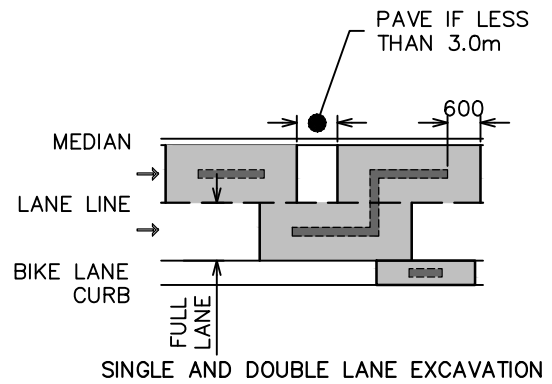

**PARALLEL CUTS
(PERMANENT RESTORATION)**

NOTES:

1. TEMPORARY PATCH CAN REMAIN; PROVIDED TESTS AND INSPECTIONS CONFIRM THE WORK IS COMPLETED IN ACCORDANCE WITH CITY OF SURREY SUPPLEMENTARY SPECIFICATIONS 31.23.01, 32.12.16 AND 32.12.17.
2. PERMANENT REPAIR MUST BE COMPLETED WITHIN 60 DAYS, WEATHER PERMITTING.
3. IF EXISTING THICKNESS IS LESS THAN 70mm, THEN FULL DEPTH MILL WILL BE REQUIRED FOR FULL LANE WIDTH.
4. IF THE ROAD HAS NO PAVEMENT MARKINGS, THEN EXTENT OF PAVING WILL BE TO EDGE OF PAVEMENT.
5. OVERLAY MUST COVER FULL LANE WIDTH, FROM LANE LINE TO LANE LINE. IF PAVEMENT CUT STRADDLES TWO LANES, THEN PAVE BOTH LANES.
6. IF THE CUT AREA (EXISTING AND NEW) ON A QUARTER OF THE INTERSECTION IS 50% PERMANENT RESTORATION OR MORE BY AREA, THEN THE ENTIRE AFFECTED QUARTER MUST BE PAVED, OTHERWISE PAVE FULL LANE ENTIRE WIDTH.
7. REFER TO SSD-G.5 FOR STANDARD ROAD STRUCTURE SECTION.
8. BUTT JOINTS TO HAVE 600mm OVERLAP IN LATERAL DIRECTION.

3		All Dimensions Shown In Millimetres, Unless Otherwise Noted	
	APRIL 2020	VICTOR JHINGAN	
1	JANUARY 2016	SCOTT NEUMAN	Title
	Revision Date	Approved	TRENCH CUTS
CITY OF SURREY the future lives here.		SUPPLEMENTARY STANDARD DRAWINGS	Approved By : APRIL 2020 G.M. Engineering
			DRAWING NUMBER SSD-G.2

SURFACE LIFT ASPHALT
REINSTATEMENT SEE
NOTES 1, 2 AND 3

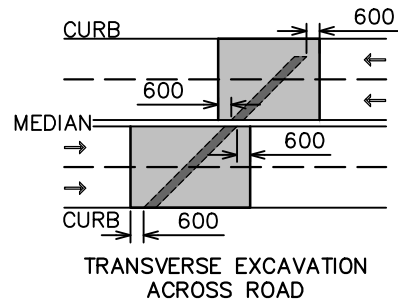
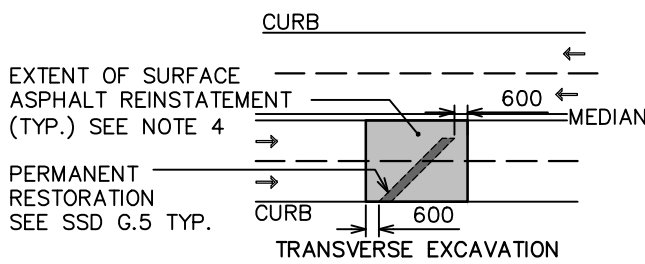
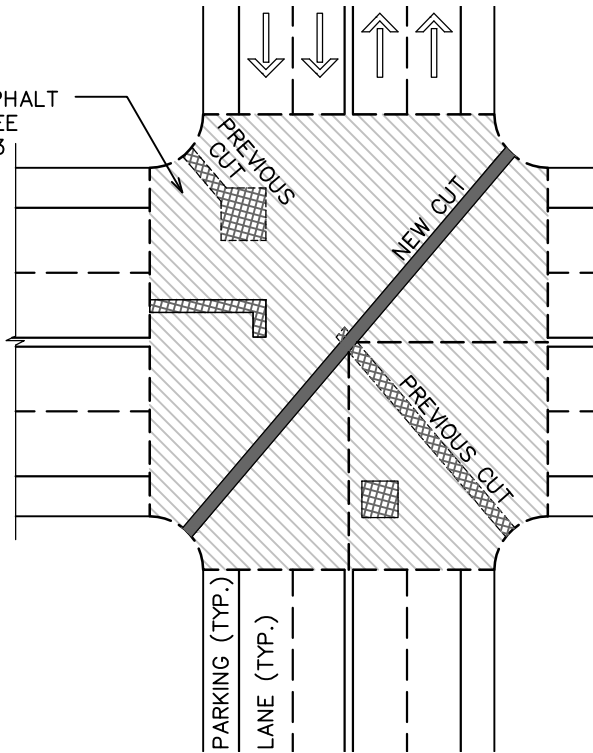



NOTES:

1. IF THE CUT AREA (EXISTING AND NEW) ON A QUARTER OF THE INTERSECTION IS 50% PERMANENT RESTORATION OR MORE BY AREA, THEN THE ENTIRE AFFECTED QUARTER MUST BE PAVED.
2. IF CUT IMPACT AREA (EXISTING AND NEW) IS LESS THAN 50% OF ANY INTERSECTION QUARTER BUT MORE THAN 35% OF ENTIRE INTERSECTION THEN PAVING THE ENTIRE INTERSECTION IS REQUIRED.
3. SURFACE ASPHALT RESTORATION INVOLVES MILL/OVERLAY TO DEPTH OF UPPER COURSE ASPHALT AS NOTED ON SSD-G.5.

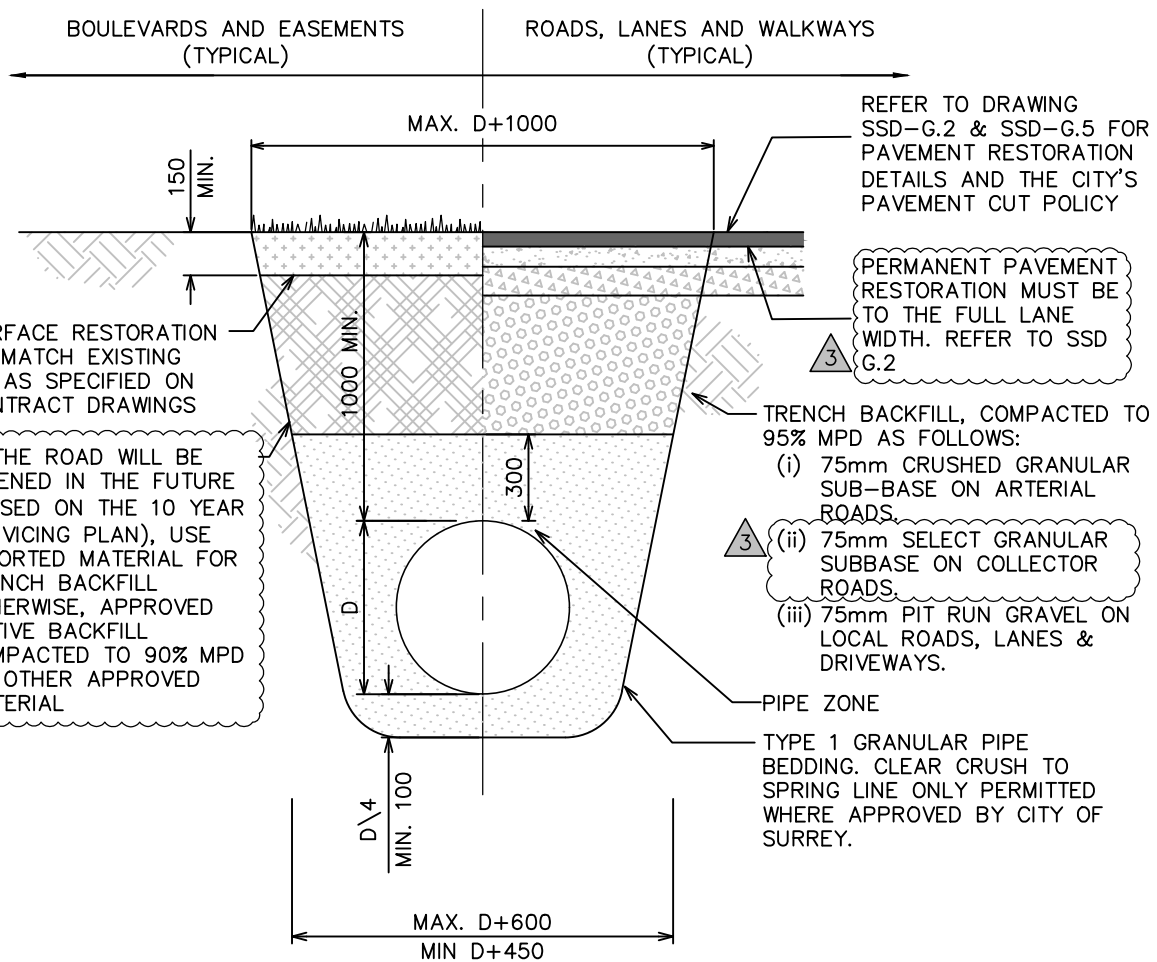
3			All Dimensions Shown In Millimetres, Unless Otherwise Noted
2	APRIL 2020	SCOTT NEUMAN	
1	JANUARY 2016	SCOTT NEUMAN	Title
	Revision Date	Approved	IRREGULAR & DIAGONAL CUTS
			Approved By : APRIL 2020 G.M. Engineering
SUPPLEMENTARY STANDARD DRAWINGS			DRAWING NUMBER SSD-G.3



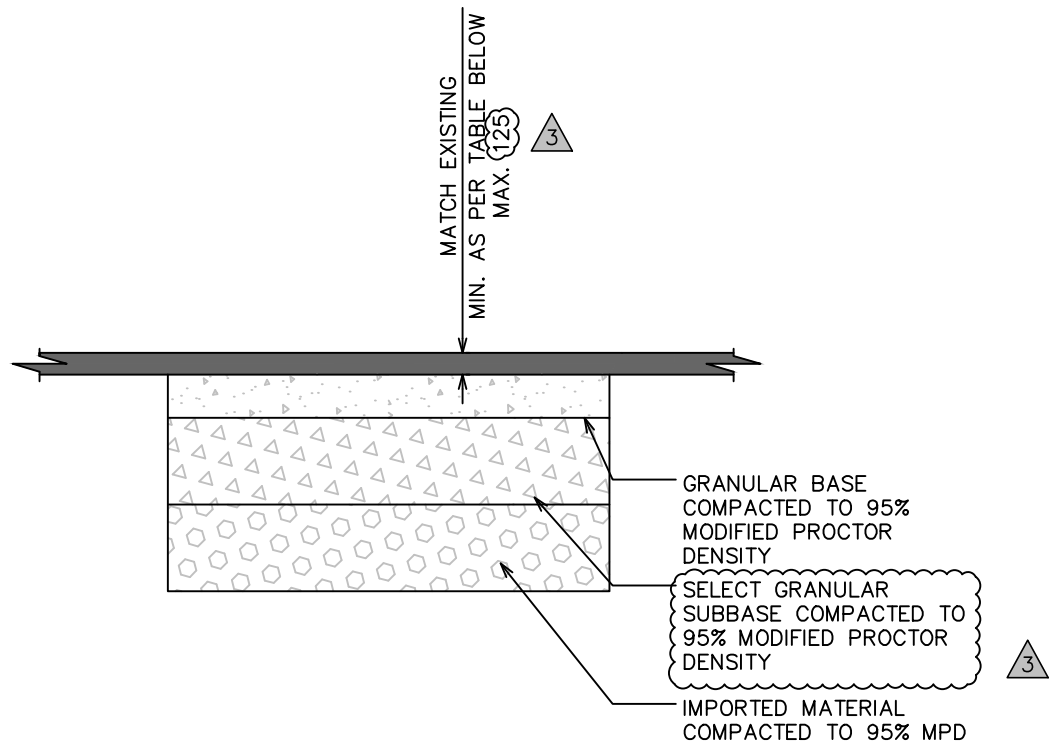

NOTES: 1. TRENCHING TO COMPLY WITH ALL REQUIREMENTS OF WORKSAFE B.C.
2. REFER TO CONTRACT DRAWINGS, SECTION 31 23 01 FOR DETAILED SPECIFICATIONS.

3	APRIL 2020	VICTOR JHINGAN	All Dimensions Shown In Millimetres, Unless Otherwise Noted
	2	JULY 2016	
1	JANUARY 2016	SCOTT NEUMAN	Title UTILITY TRENCH
	Revision Date	Approved	
 SUPPLEMENTARY STANDARD DRAWINGS			Approved By :  APRIL 2020 G.M. Engineering
			DRAWING NUMBER SSD-G.4



	UPPER COURSE ASPHALT	LOWER COURSE ASPHALT	BASE COURSE (min.)	SUB-BASE COURSE (min.)
ARTERIALS	50mm SUPER PAVE (12.5mm)	75mm SUPER PAVE (19mm)	150mm 19mm CRUSHED GRANULAR BASE	250mm 75mm CRUSHED GRANULAR SUBBASE
COLLECTORS	40mm UPPER COURSE 1	60mm LOWER COURSE 1	100mm 19mm CRUSHED GRANULAR BASE	200mm 75mm SELECT GRANULAR SUBBASE
LOCAL ROADS	35mm UPPER COURSE 2	50mm LOWER COURSE 2	100mm 19mm CRUSHED GRANULAR BASE	200mm 75mm SELECT GRANULAR SUBBASE
LANES & NON-RESIDENTIAL DRIVEWAYS	35mm UPPER COURSE 2	50mm LOWER COURSE 2	100mm 19mm CRUSHED GRANULAR BASE	100mm 75mm SELECT GRANULAR SUBBASE
RESIDENTIAL DRIVEWAYS	65mm UPPER COURSE 2 (1 LIFTS)		100mm 19mm CRUSHED GRANULAR BASE	100mm 75mm SELECT GRANULAR SUBBASE

NOTE: 1. REFER TO CONTRACT DOCUMENT SECTIONS 31 23 01, 32 12 16 AND 32 12 17 FOR SPECIFICATIONS.

3	APRIL 2020	SCOTT NEUMAN	All Dimensions Shown In Millimetres, Unless Otherwise Noted
2	JULY 2016	SCOTT NEUMAN	
1	JANUARY 2016	SCOTT NEUMAN	Title STANDARD ROAD STRUCTURE SECTIONS
	Revision Date	Approved	
 SUPPLEMENTARY STANDARD DRAWINGS			Approved By :  APRIL 2020 G.M. Engineering
			DRAWING NUMBER SSD-G.5

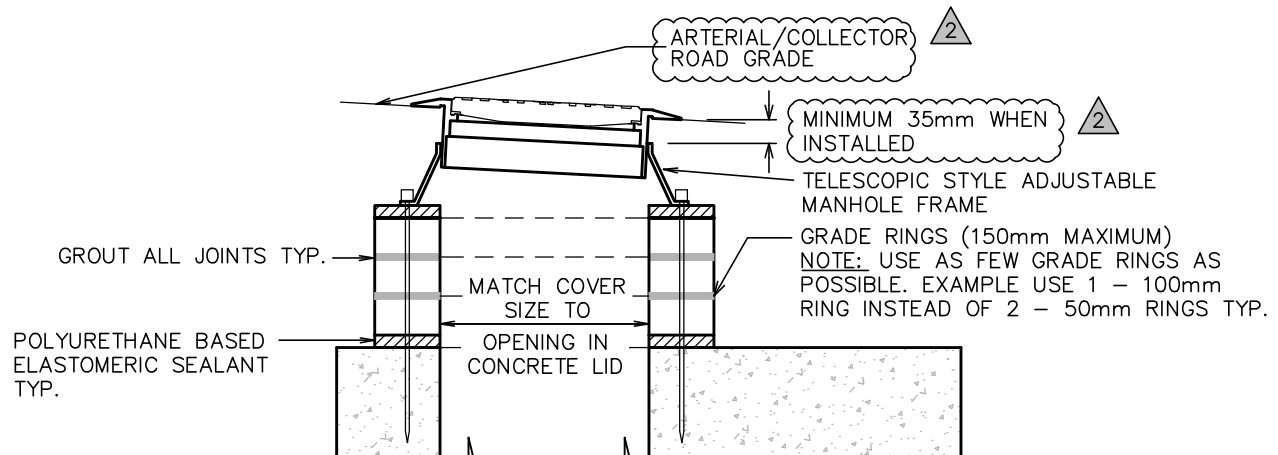

TYPE I HEIGHT ADJUSTABLE MANHOLE FRAME AND COVER

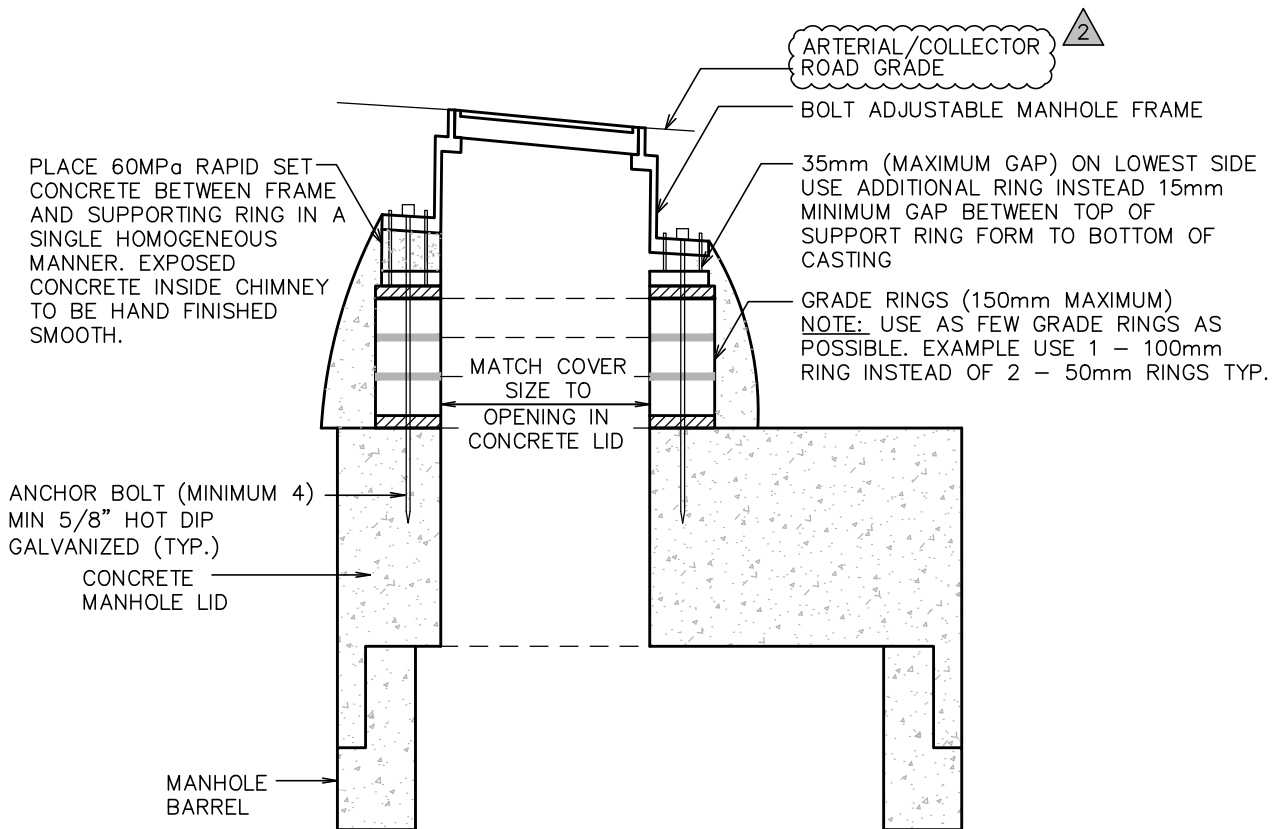

TYPE II HEIGHT ADJUSTABLE MANHOLE FRAME AND COVER

NOTES: 1. FOR ROAD GRADES GREATER THAN 8%, SLOPE GRADE RINGS SHALL BE USED.

3			All Dimensions Shown In Millimetres, Unless Otherwise Noted
	APRIL 2020	SCOTT NEUMAN	
1	JANUARY 2016	ROBERT LEE	
	Revision Date	Approved	Title TYPE I & II HEIGHT ADJUSTABLE MANHOLE FRAME AND COVER
	SUPPLEMENTARY STANDARD DRAWINGS	Approved By :	DRAWING NUMBER SSD-G.6
		APRIL 2020	G.M. Engineering

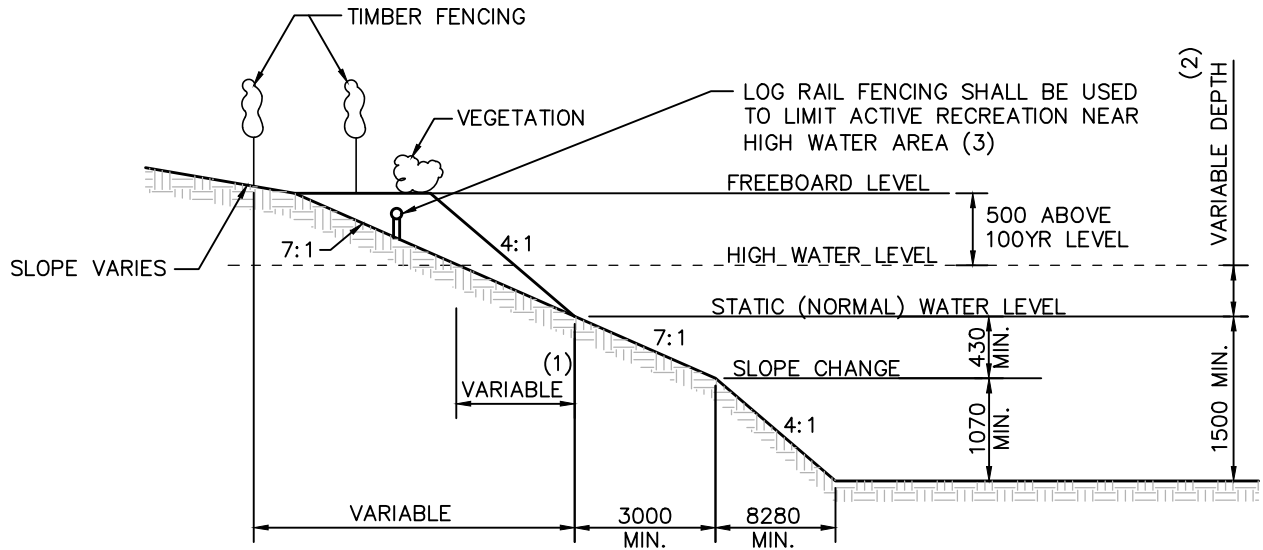

NOTES:

1. MAXIMUM SIDE SLOPE OF 4:1 (H:V) MAY BE USED PROVIDED ADEQUATE VEGETATION IS USED TO PREVENT ACCESS.
2. MAXIMUM 2.0m FOR ≤ 5 YEAR LEVEL AND 3.0m FOR THE 100 YEAR LEVEL.
3. LOG RAIL SHOULD BE AT LEAST 1.0m FROM HWL

3			All Dimensions Shown In Metres, Unless Otherwise Noted
2	APRIL 2020	SCOTT NEUMAN	
1	JANUARY 2016	CAROLYN BARON	Title
	Revision Date	Approved	SIDE SLOPES FOR DETENTION PONDS
CITY OF SURREY <small>the future lives here.</small>			Approved By : APRIL 2020 G.M. Engineering
			DRAWING NUMBER SSD-D.1

ACCESS GATE LOCATION TO BE DETERMINED BY PARKS

LANDSCAPING TO BE EXTENDED TO BACK OF CURB OR SIDEWALK

CURB LINE

ROAD ALLOWANCE

DECORATIVE FENCE ALONG ROAD ALLOWANCE

ADJACENT LOTS

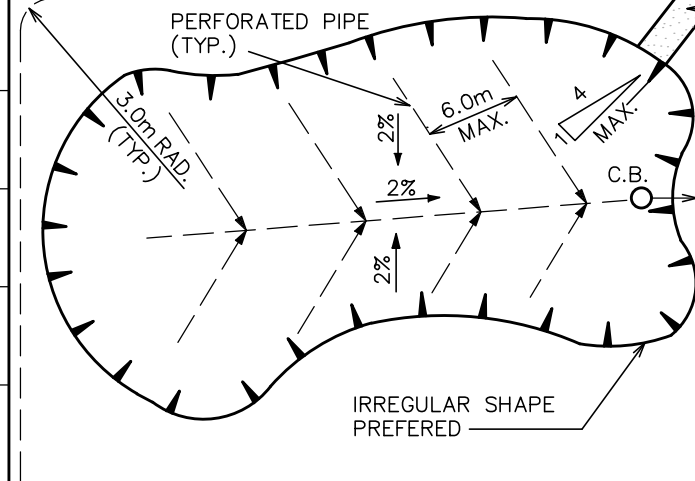

SPILLWAY—WIDTH AS REQUIRED FOR MAJOR FLOW

CONTROL MANHOLE AS PER SSD-D3 OR SSD-D4

STORM SEWER



ADJACENT LOTS

TEMPORARY SNOW FENCE OR 1.7m PERMANENT WOODEN PRIVACY FENCE AS DIRECTED BY THE CITY OF SURREY

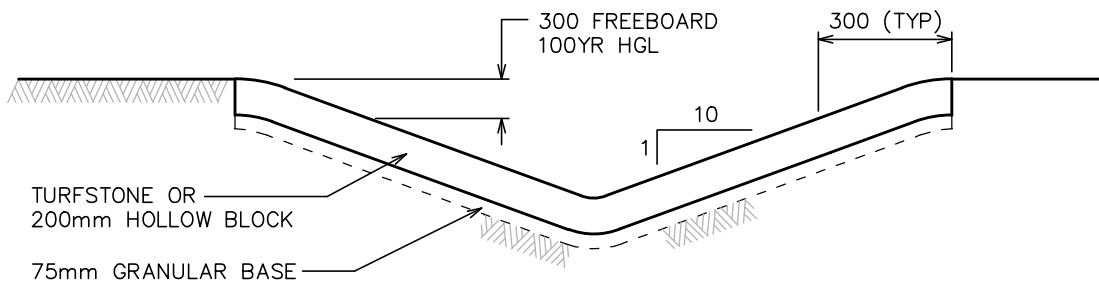
PLAN



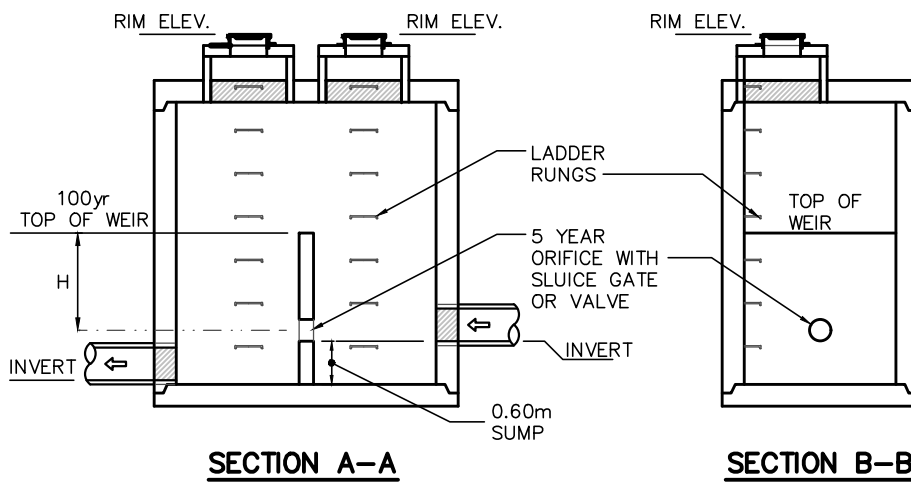
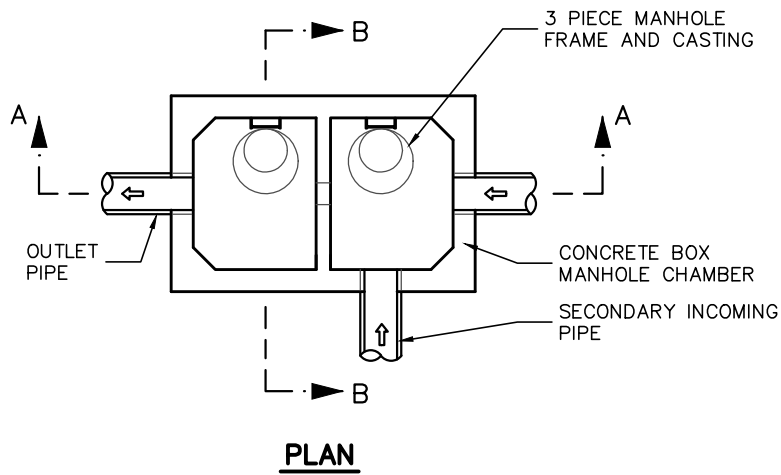

SPILLWAY SECTION

3			All Dimensions Shown In Millimetres, Unless Otherwise Noted
2	APRIL 2020	SCOTT NEUMAN	
1	JANUARY 2016	CAROLYN BARON	
	Revision Date	Approved	Title DETENTION BASIN PLAN VIEW
 <p>the future lives here.</p>			Approved By :  APRIL 2020 G.M. Engineering
SUPPLEMENTARY STANDARD DRAWINGS			DRAWING NUMBER SSD-D.2



NOTES

1. "H" REFERS TO HYDRAULIC HEAD
2. CHAMBER SIZE TO BE DETERMINED BY THE SIZE OF THE INCOMING PIPE

3			All Dimensions Shown In Millimetres, Unless Otherwise Noted
2	APRIL 2020	SCOTT NEUMAN	
1	JANUARY 2016	CAROLYN BARON	Title FLOW CONTROL MANHOLE "A" (DETENTION POND)
	Revision Date	Approved	
 <p>CITY OF SURREY the future lives here.</p>			Approved By :  APRIL 2020 G.M. Engineering
SUPPLEMENTARY STANDARD DRAWINGS			DRAWING NUMBER SSD-D.3

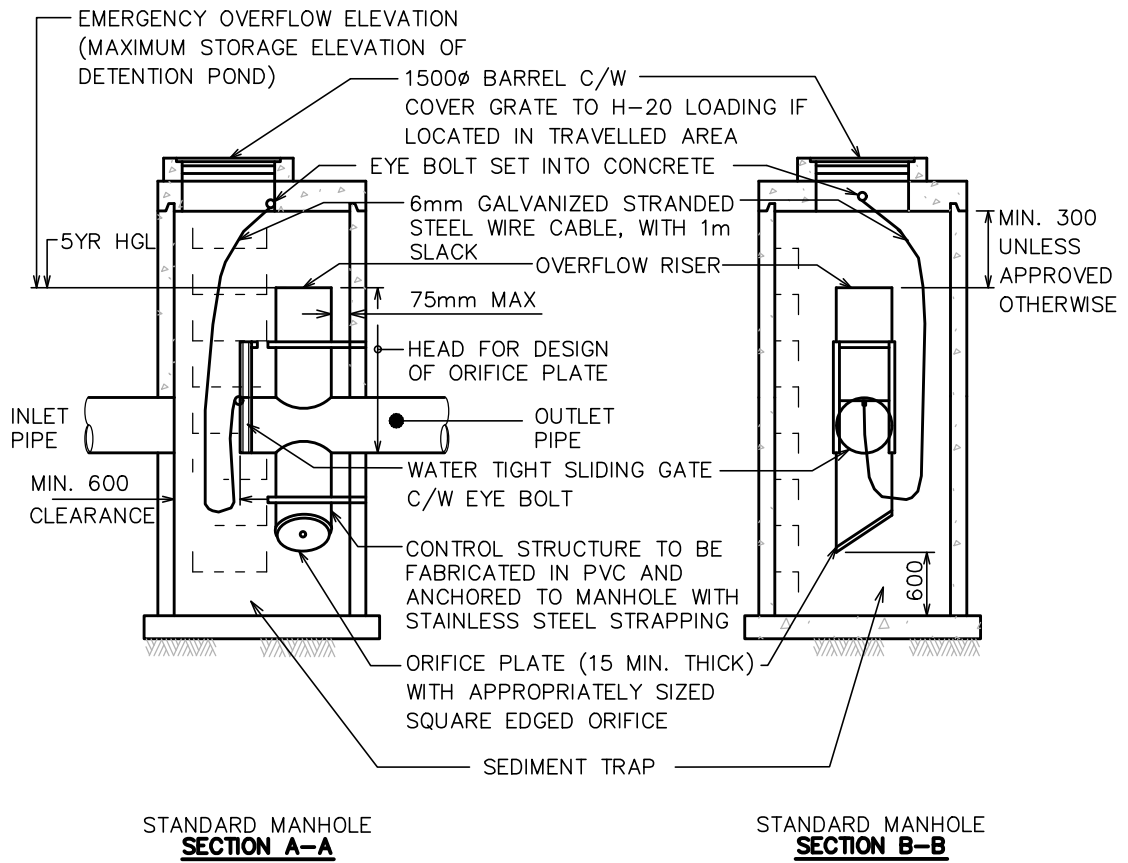
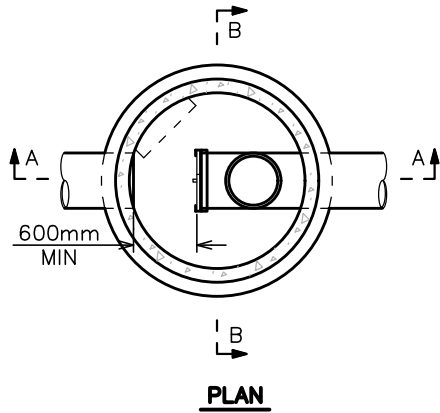

3			All Dimensions Shown In Millimeters, Unless Otherwise Noted
2	APRIL 2020	SCOTT NEUMAN	
1	JANUARY 2016	CAROLYN BARON	Title FLOW CONTROL MANHOLE "B" (DETENTION POND)
	Revision Date	Approved	Approved By :
the future lives here.			DRAWING NUMBER SSD-D.4
			APRIL 2020 G.M. Engineering

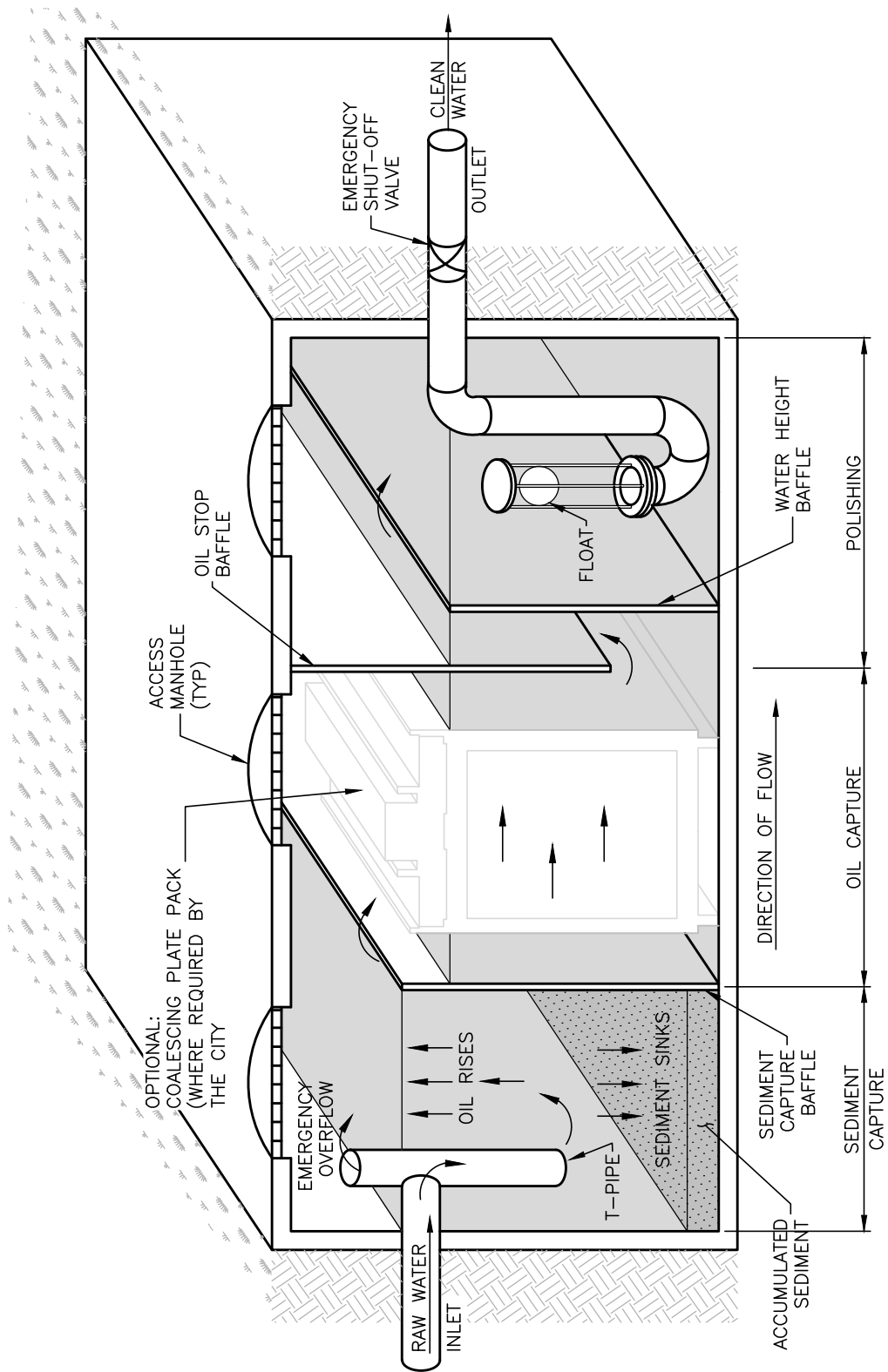

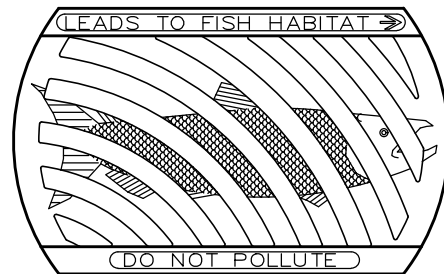
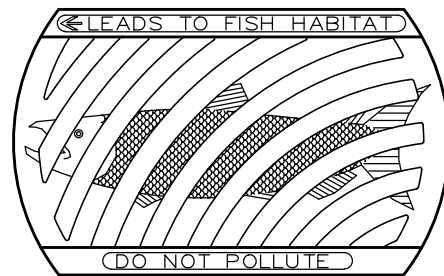
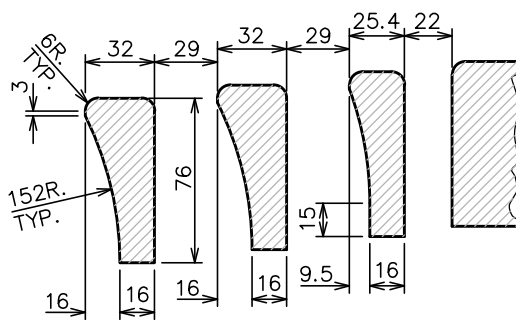
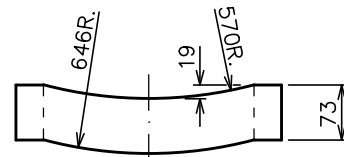
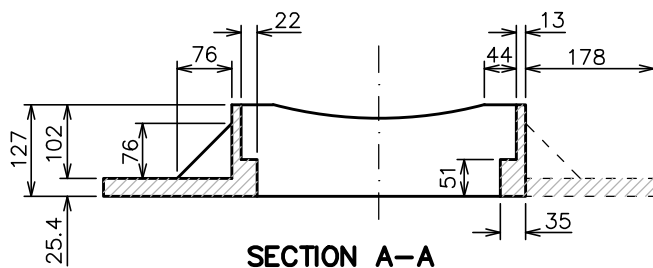
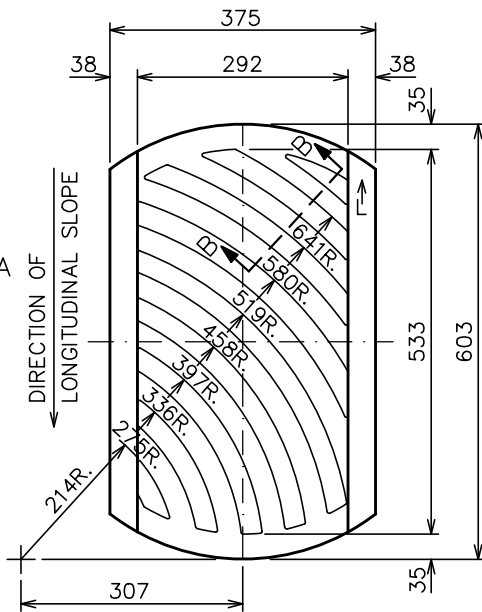
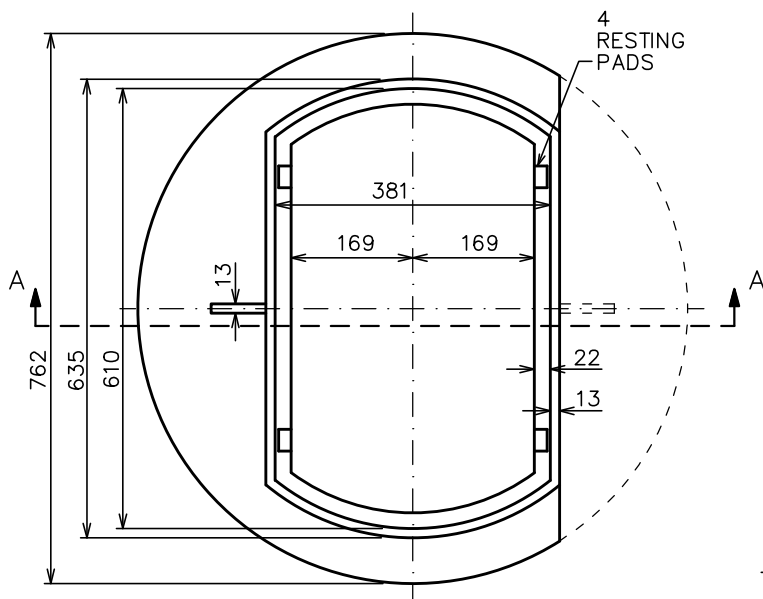

NOTE: REFER TO CITY OF SURREY DESIGN CRITERIA MANUAL FOR SIZING REQUIREMENTS AND ALTERNATE PRODUCTS.

3	APRIL 2020	SCOTT NEUMAN	All Dimensions Shown In Millimetres, Unless Otherwise Noted
2	JANUARY 2016	CAROLYN BARON	
1	MARCH 2002		
	Revision Date	Approved	Title
			OIL/GREASE SEPARATOR
			Approved By :
SUPPLEMENTARY STANDARD DRAWINGS			
			APRIL 2020
			G.M. Engineering
			DRAWING NUMBER
			SSD-D.5



NOTE:

1. SYMBOL OF FISH TO BE INDENTED ON TOP OF GRATE BY 3mm.

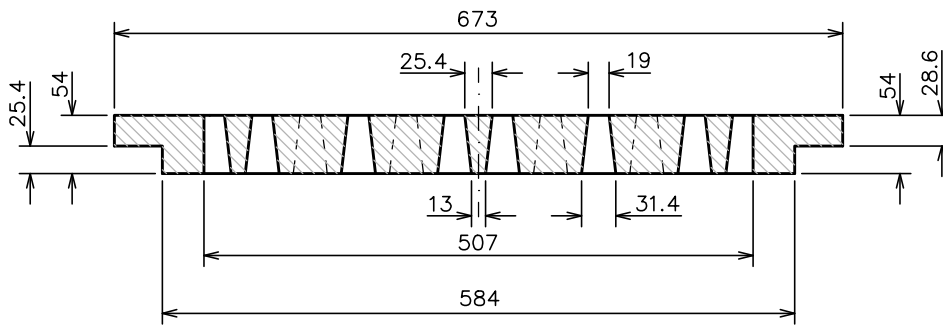
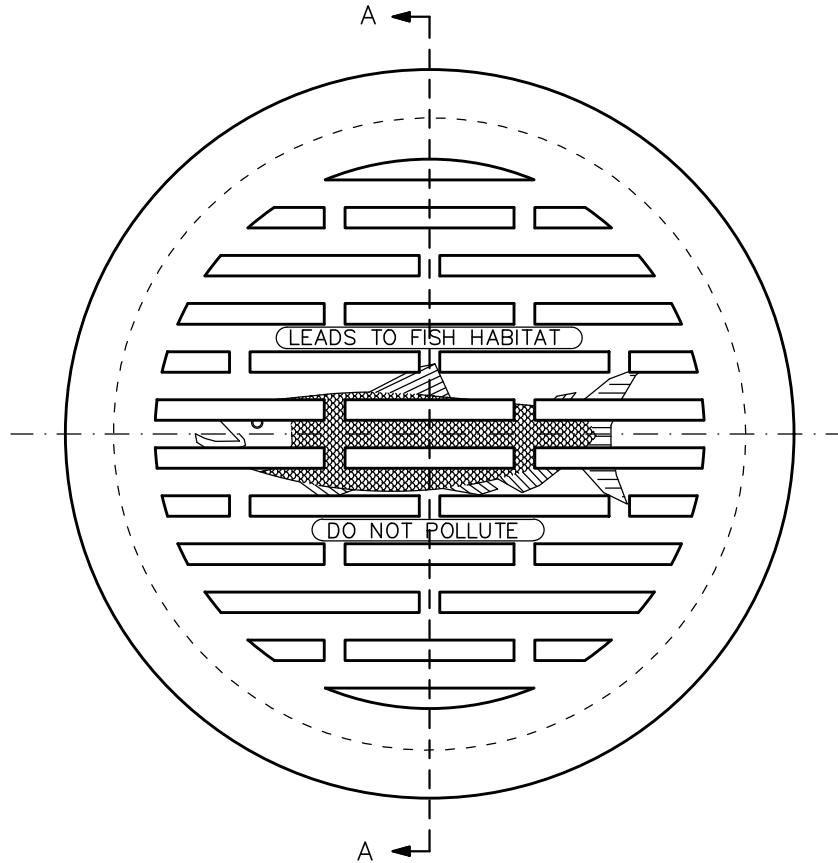

3			All Dimensions Shown In Millimetres, Unless Otherwise Noted
2	APRIL 2020	SCOTT NEUMAN	
1	JANUARY 2016	CAROLYN BARON	
	Revision Date	Approved	Title DRAINAGE GRATE AND FRAME
 <p>CITY OF SURREY the future lives here.</p>			Approved By :  APRIL 2020 G.M. Engineering
SUPPLEMENTARY STANDARD DRAWINGS			DRAWING NUMBER SSD-D.6



SECTION A-A

NOTES:

1. SYMBOL OF FISH TO BE INDENTED ON TOP OF GRATE BY 3mm.
2. FOR INTENDED USE WITHIN CITY R/W's.

3			All Dimensions Shown In Millimetres, Unless Otherwise Noted
2	APRIL 2020	SCOTT NEUMAN	
1	JANUARY 2016	CAROLYN BARON	
	Revision Date	Approved	Title BOULEVARD BASIN GRATE
 <p>CITY OF SURREY the future lives here.</p>			<p>Approved By : </p> <p>APRIL 2020 G.M. Engineering</p>
			DRAWING NUMBER SSD-D.7

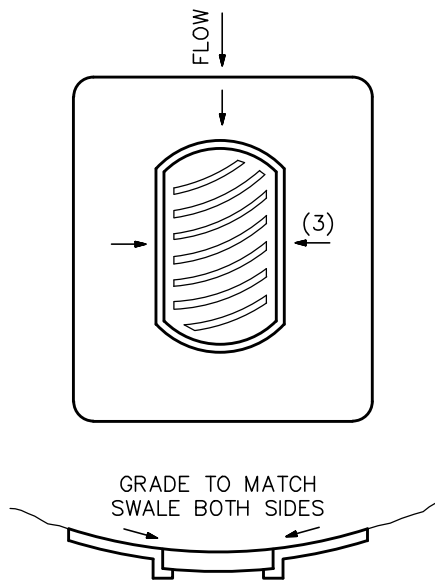

**SWALE TYPE APRON
FOR GRADE UP TO 3%**

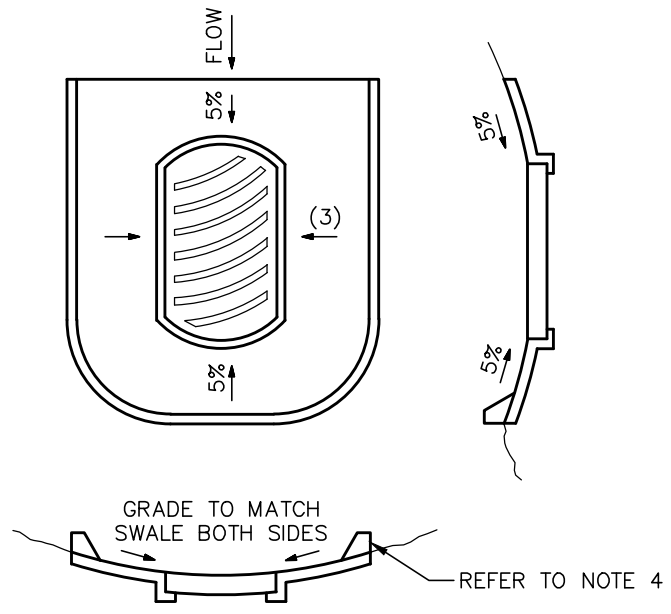

**CURB TYPE APRON
FOR GRADES FROM 3-5%**

NOTES:

1. ALL ASPHALT TO BE LOWER COURSE #2.
2. APRON THICKNESS 50mm.
3. MINIMUM WIDTH OF ASPHALT SURROUND IS 500mm.
4. ALL APRON CURB 75x255 EXTRUDED OR FORMED CURB.
5. CATCH BASIN FRAME PER SSD-D.6

3			All Dimensions Shown In Millimetres, Unless Otherwise Noted Title ASPHALT APRONS FOR CATCH BASINS
2	APRIL 2020	SCOTT NEUMAN	
1	JANUARY 2016	CAROLYN BARON	
	Revision Date	Approved	



SUPPLEMENTARY
STANDARD
DRAWINGS

Approved By : 
APRIL 2020 G.M. Engineering

DRAWING NUMBER
SSD-D.8

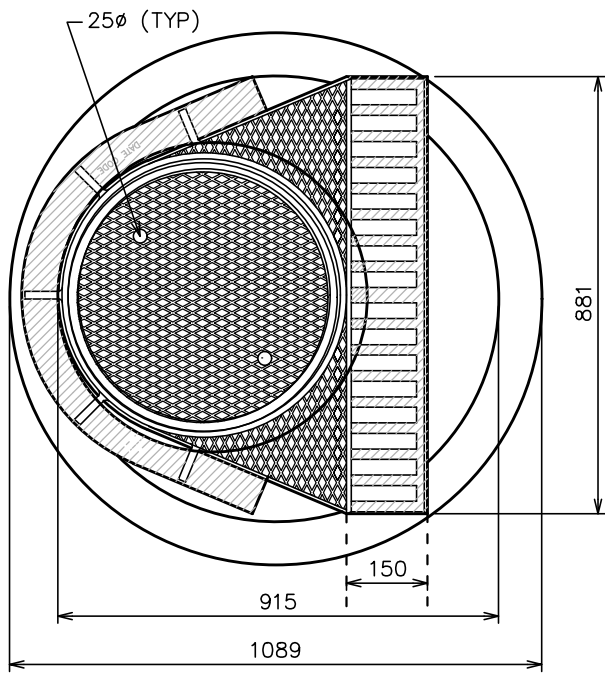

PLAN

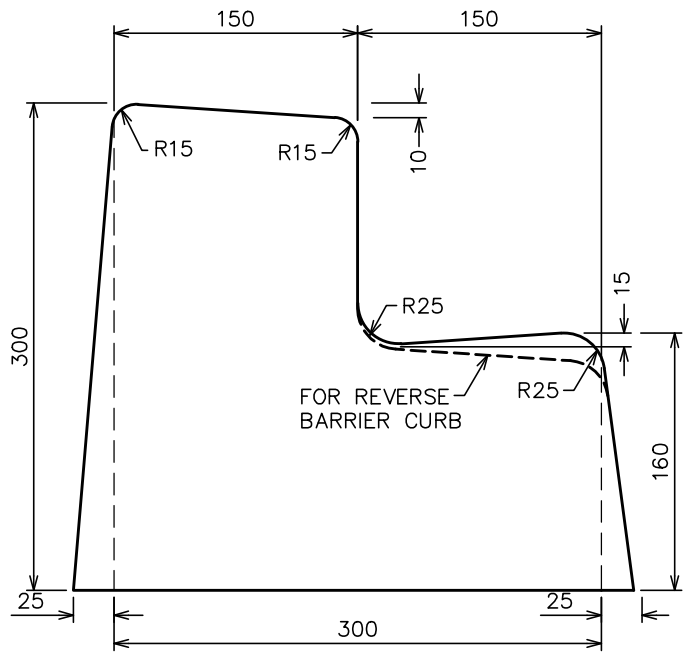

BIKE FRIENDLY BARRIER CURB

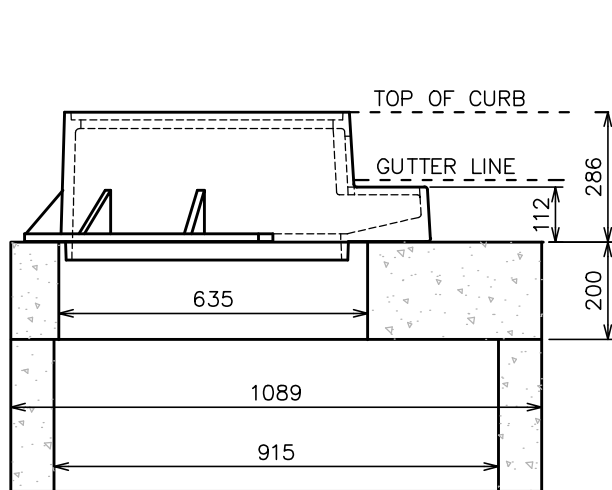

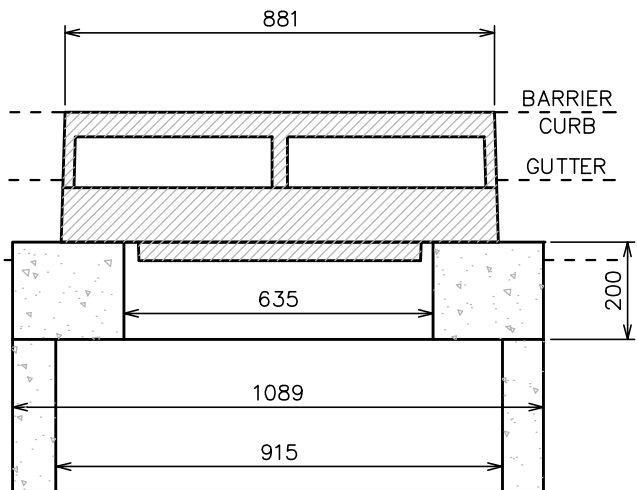

SECTION



CURB VIEW

NOTES:
1. FOR USE WITH NARROW GUTTER PAN.

3			All Dimensions Shown In Meters, Unless Otherwise Noted
2	APRIL 2020	SCOTT NEUMAN	
1	JANUARY 2016	JAIME BOAN	Title BIKE FRIENDLY CATCH BASIN
	Revision Date	Approved	
 <p>CITY OF SURREY the future lives here.</p>			Approved By :  APRIL 2020 G.M. Engineering
SUPPLEMENTARY STANDARD DRAWINGS			DRAWING NUMBER SSD-D.9

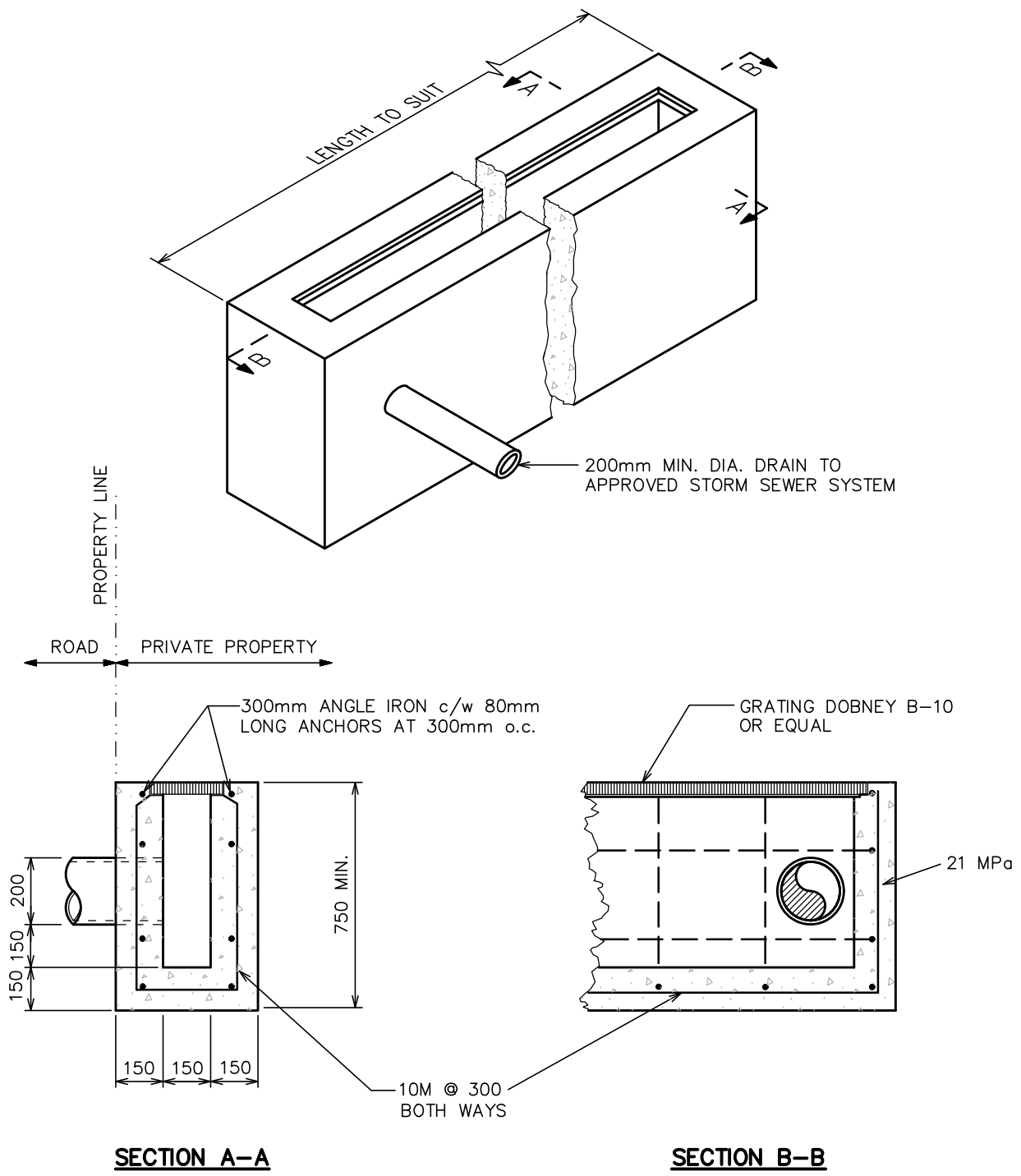

3			All Dimensions Shown In Millimetres, Unless Otherwise Noted
2	APRIL 2020	SCOTT NEUMAN	
1	JANUARY 2016	CAROLYN BARON	
	Revision Date	Approved	Title COMMERCIAL DRIVEWAY SUMP



SUPPLEMENTARY STANDARD DRAWINGS

Approved By : *[Signature]*
 APRIL 2020 G.M. Engineering

DRAWING NUMBER
SSD-D.10

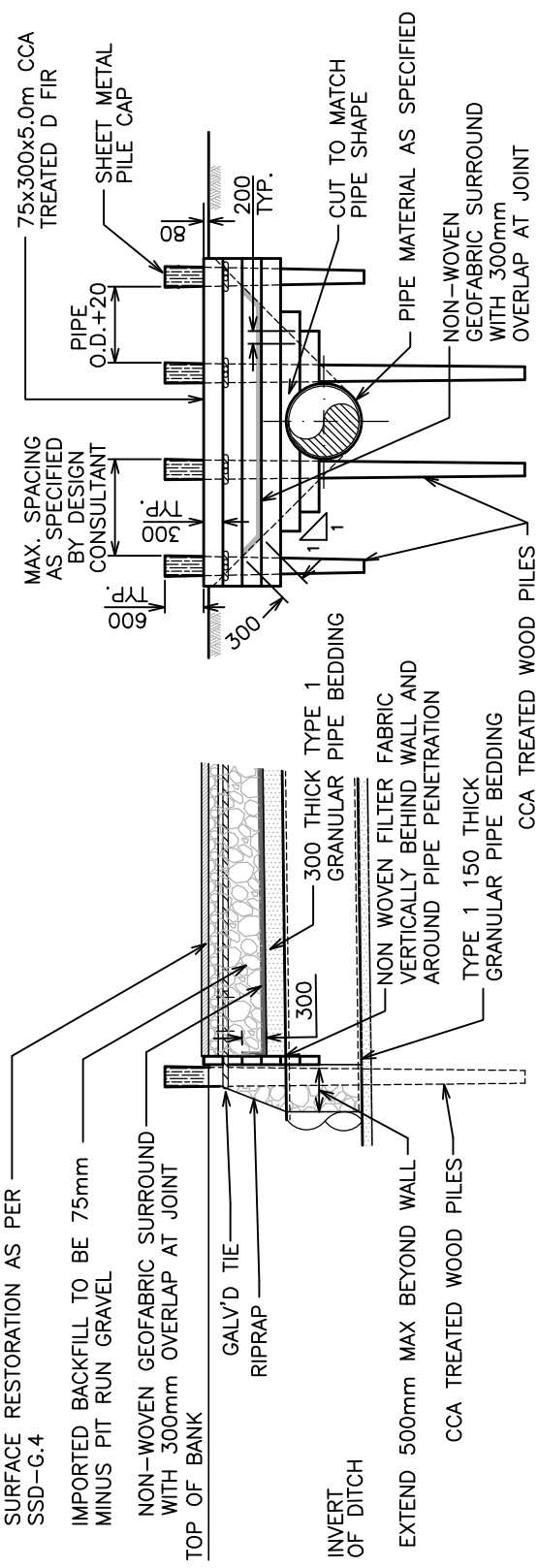
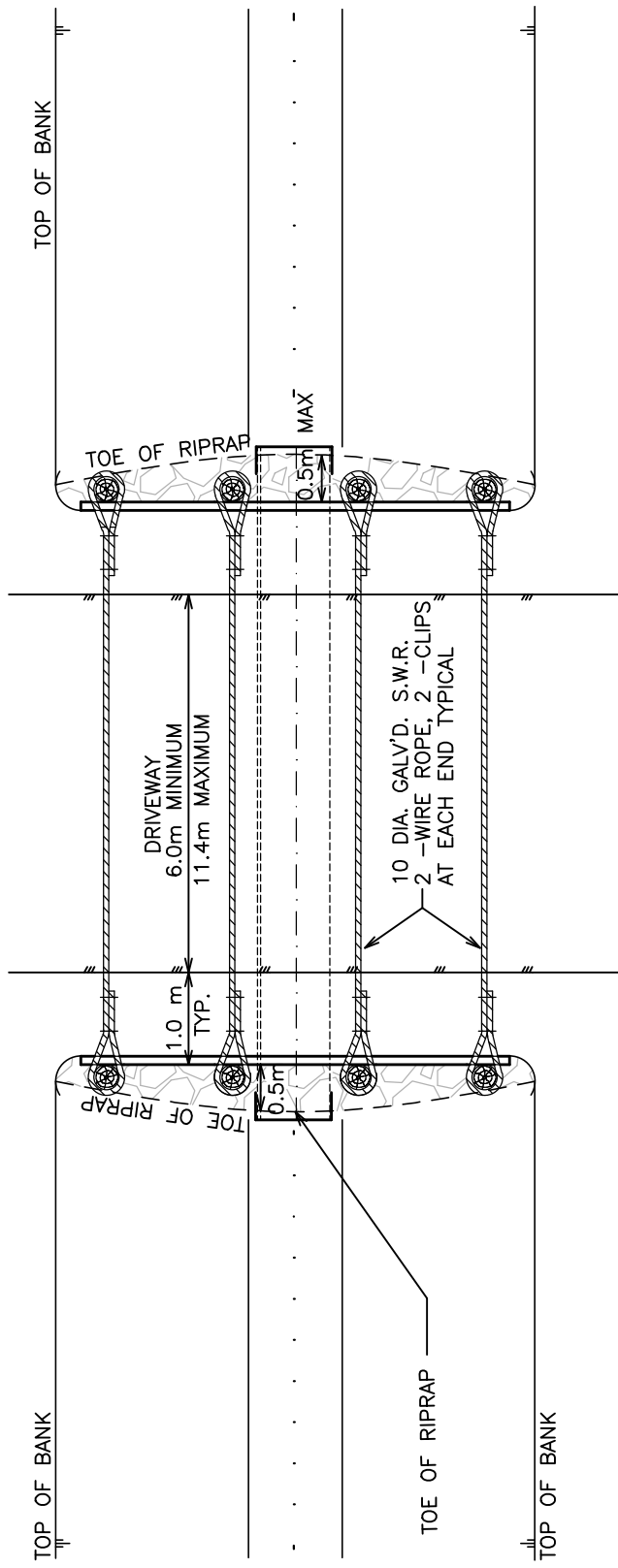

NOTES:
 1. FILL BETWEEN HEADWALLS WITH GRANULAR BACKFILL EXCEPT FOR THE TOP 150mm WHICH SHALL BE GRANULAR BASE.

3		
2	APRIL 2020	SCOTT NEUMAN
1	JANUARY 2016	CAROLYN BARON
	Revision Date	Approved

All Dimensions Shown In Millimeters, Unless Otherwise Noted

Title **TIMBER HEADWALL DETAILS FOR USE ONLY IN LOWLANDS**



SUPPLEMENTARY STANDARD DRAWINGS

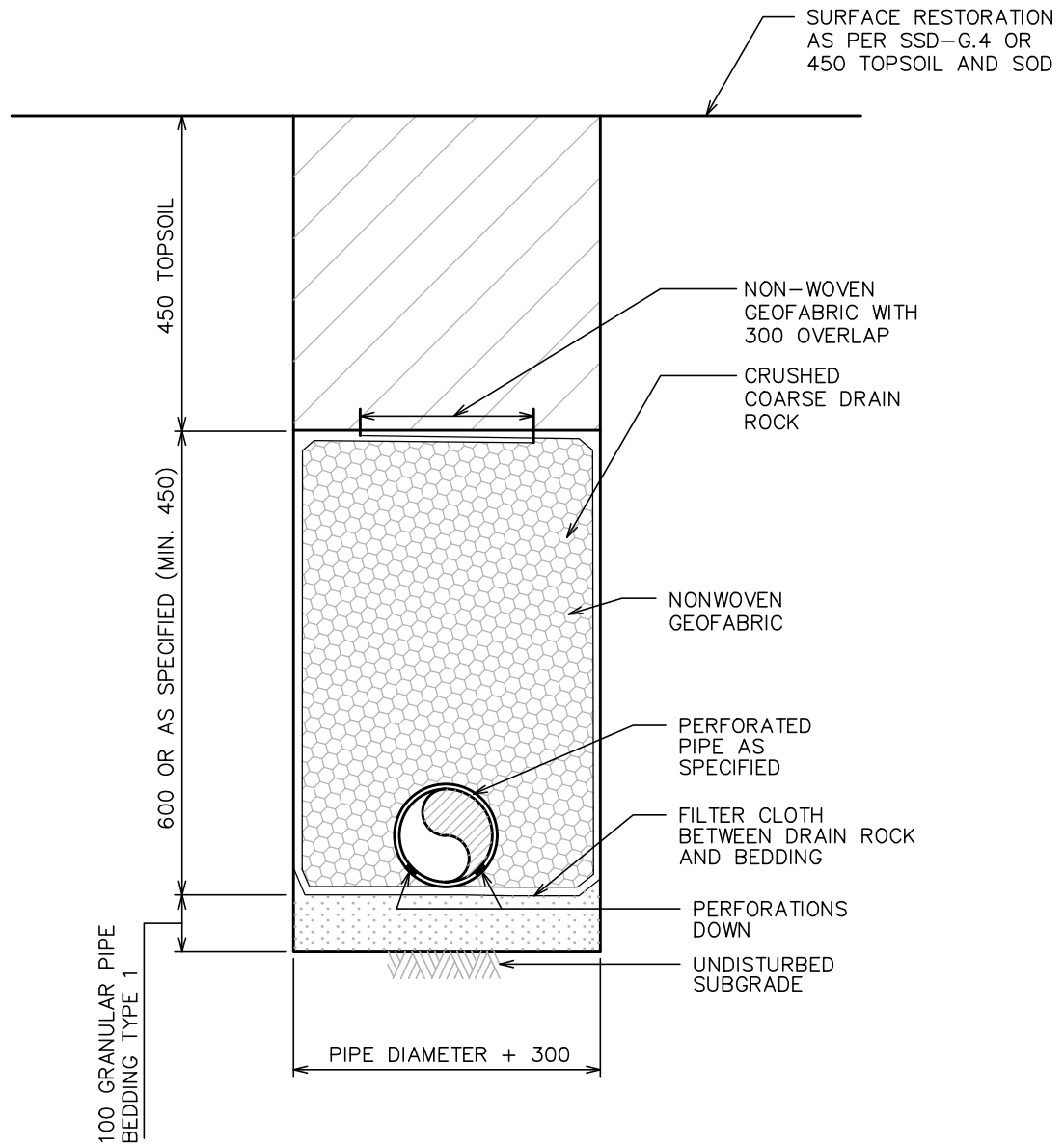

Approved By : *[Signature]*
 APRIL 2020 G.M. Engineering

DRAWING NUMBER
SSD-D.11



FILTER FABRIC MINIMUM SPECIFICATIONS:

- (A) TENSILE STRENGTH 0.4 kN MINIMUM
- (B) PUNCTURE STRENGTH 1.1 kN MINIMUM
- (C) PERMEABILITY MIN. 5 TIMES PERMEABILITY OF SOIL RETAINED

3			All Dimensions Shown In Millimetres, Unless Otherwise Noted
2	APRIL 2020	SCOTT NEUMAN	
1	JANUARY 2016	CAROLYN BARON	
	Revision Date	Approved	Title SUBDRAIN
 <p>CITY OF SURREY the future lives here.</p>			<p>Supplementary Standard Drawings</p> <p>Approved By :  G.M. Engineering</p>
			DRAWING NUMBER SSD-D.12

3

INSPECTION CHAMBER AS PER DRAWING SSD-G.1.1, DR35 PVC RISER. CAP TO BE PIGMENTED RED

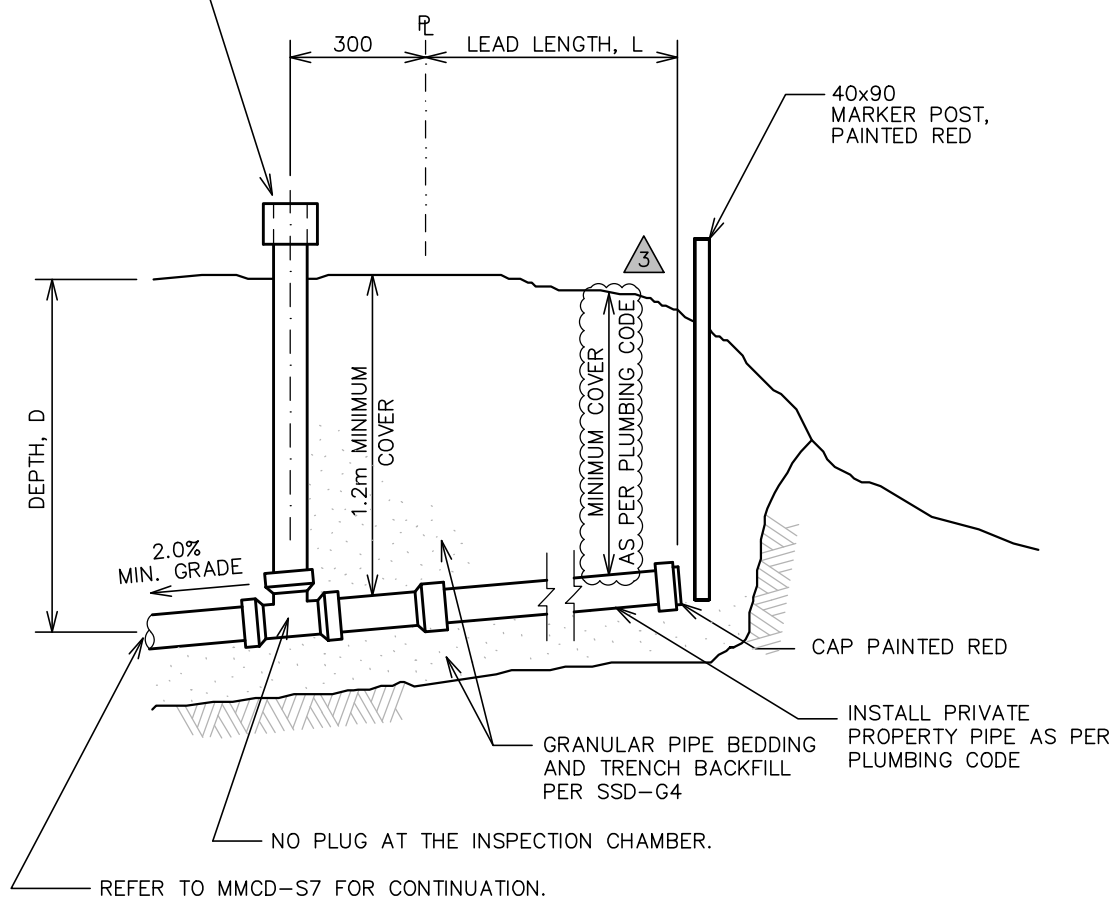

NOTES:

1. LEAD LENGTH, L = DEPTH, D OR 2.0m WHICHEVER IS GREATER.
2. SERVICE LEADS TO BE 100mm DIA. DR28 (WHITE) FOR SINGLE FAMILY RESIDENTIAL AND 150mm FOR COMMERCIAL/INDUSTRIAL OR AS SPECIFIED ON CONTRACT DRAWINGS.
3. FACTORY INSTALLED PLUG SHOULD NOT BE INSTALLED AT THE INSPECTION CHAMBER
4. REFER TO DESIGN CRITERIA MANUAL, SECTION 4.0 4.3.4.1, FOR TRIGGER WHEN LARGE SERVICE CONNECTIONS REQUIRE A MANHOLE AT PROPERTY LINE OR MAIN.

3	APRIL 2020	ROBERT LEE	All Dimensions Shown In Millimetres, Unless Otherwise Noted
2	JULY 2016	ROBERT LEE	
1	JANUARY 2016	ROBERT LEE	
	Revision Date	Approved	Title SANITARY SEWER SERVICE LEAD AT PROPERTY
CITY OF SURREY the future lives here.			SUPPLEMENTARY STANDARD DRAWINGS
APRIL 2020		Approved By :	DRAWING NUMBER SSD-S.1
		G.M. Engineering	

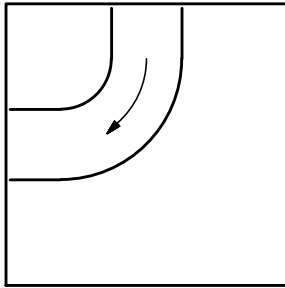

1. RIGHT ANGLE BEND

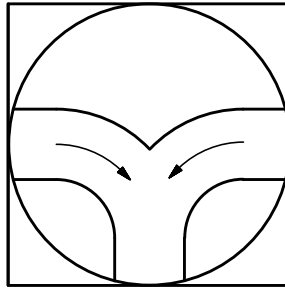

2. TEE CONNECTION

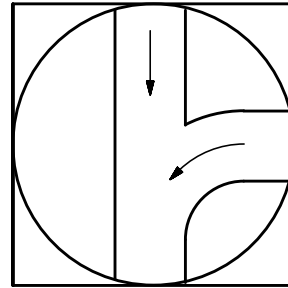

3. THREE WAY JUNCTION

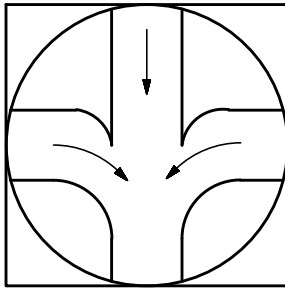

4. FOUR WAY JUNCTION

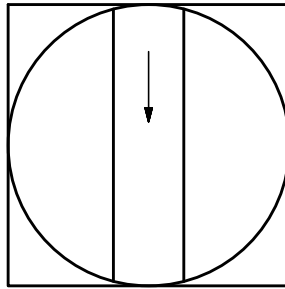

5. STRAIGHT THROUGH

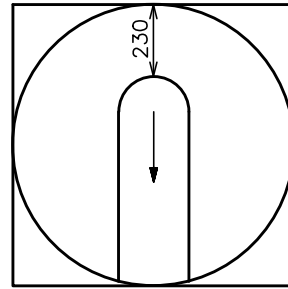

6. DEAD END

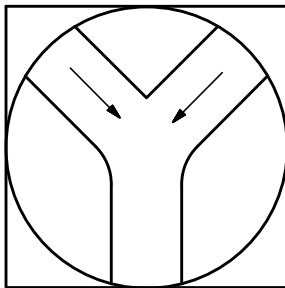

7. WYE CONNECTION

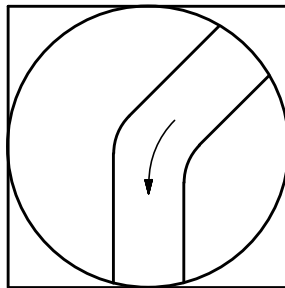

8. 45° BEND

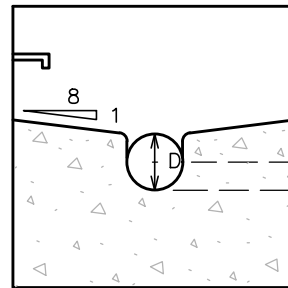

SECTION

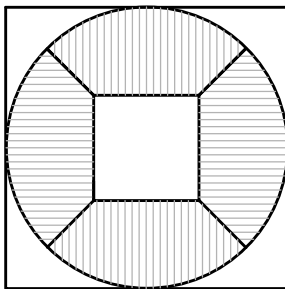

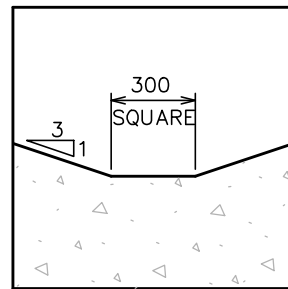

SUMP



SECTION

SUMP DETAIL

NOTES: (1) BENCHING DETAILS ARE CONCEPTUAL ONLY.
BENCHING CONFIGURATION AND INVERTS SHALL BE CHECKED FOR HYDRAULIC ADEQUACY.

3			All Dimensions Shown In Millimetres, Unless Otherwise Noted
2	APRIL 2020	SCOTT NEUMAN	
1	JANUARY 2016	ROBERT LEE	Title MANHOLE BENCHING DETAILS
	Revision Date	Approved	
			Approved By :  APRIL 2020 G.M. Engineering
SUPPLEMENTARY STANDARD DRAWINGS			DRAWING NUMBER SSD-S.2

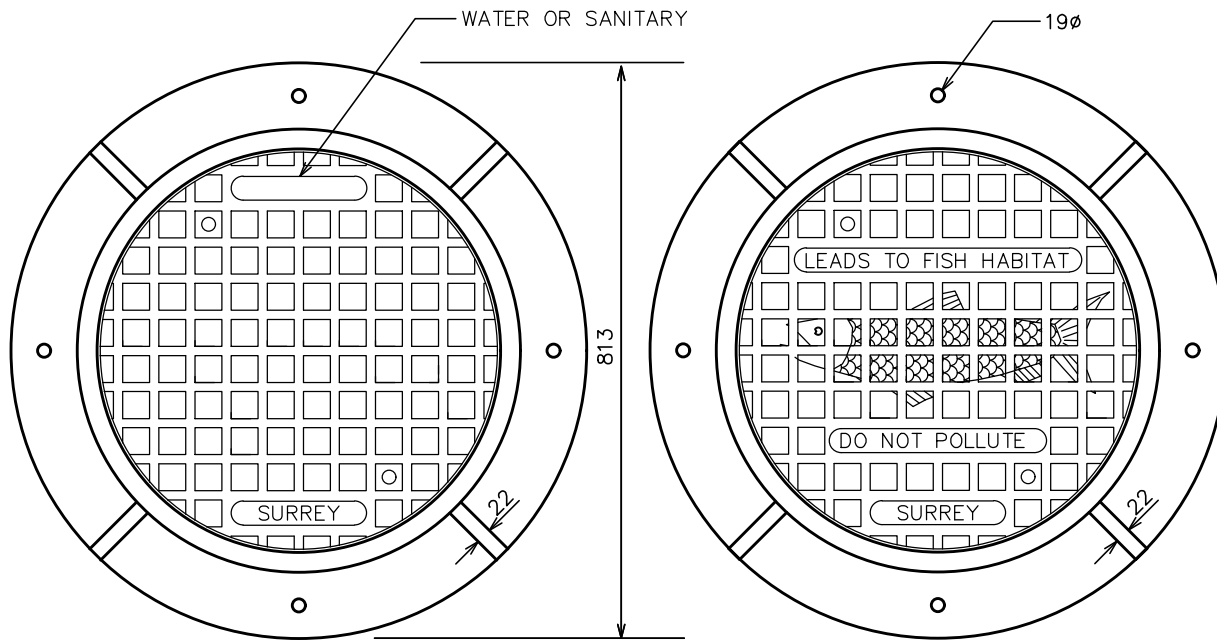

ROUND FRAME & COVER

ROUND FRAME & COVER

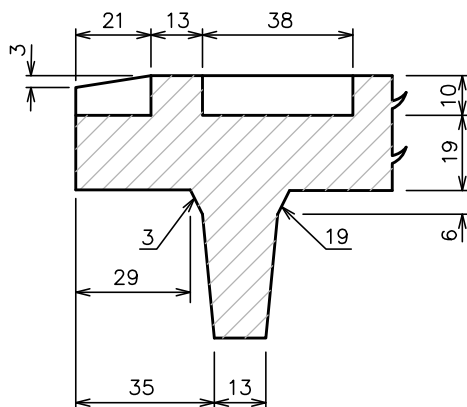

DETAIL OF RIM

MATERIAL : CAST IRON

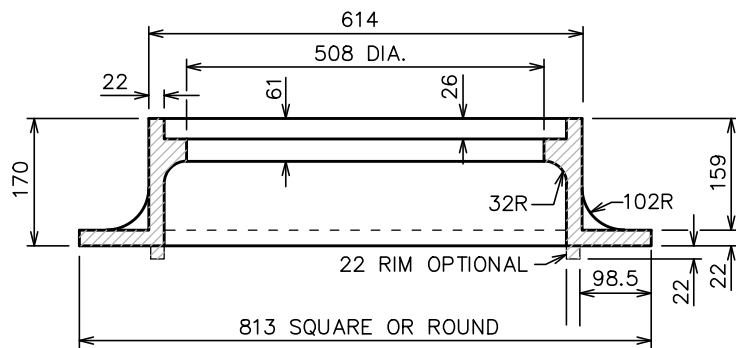

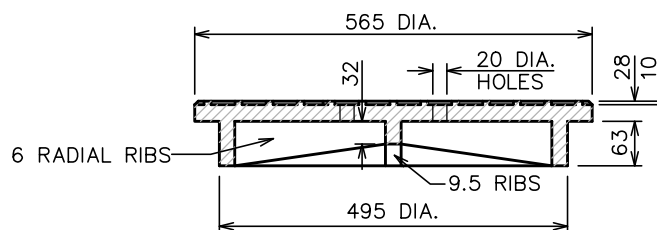

SECTION THRU FRAME



SECTION THRU COVER

- NOTES:
- ON ARTERIAL ROADS, USE TYPE 1 ADJUSTABLE MH FRAME PER SSD-S2.2
 - ON COLLECTOR ROADS, USE EITHER TYPE 1 OR TYPE 2 ADJUSTABLE MH FRAME AS PER SSD-S2.2
 - ON LOCAL ROADS USE STANDARD MH FRAME AND COVER WITH CONCRETE GRADES RINGS/RISER RINGS.
 - USE DUCTILE IRON FRAME AND COVER ON ARTERIAL ROADS.
 - SYMBOL OF FISH TO BE RAISED ON TOP OF COVER BY 8mm, APPLICABLE FOR STORM SEWER MANHOLES ONLY.

3			All Dimensions Shown In Millimetres, Unless Otherwise Noted
2	APRIL 2020	ROBERT LEE	
1	JANUARY 2016	ROBERT LEE	Title
	Revision Date	Approved	MANHOLE FRAMES AND COVER
			Approved By :
SUPPLEMENTARY STANDARD DRAWINGS			 G.M. Engineering
APRIL 2020			DRAWING NUMBER SSD-S.2.1

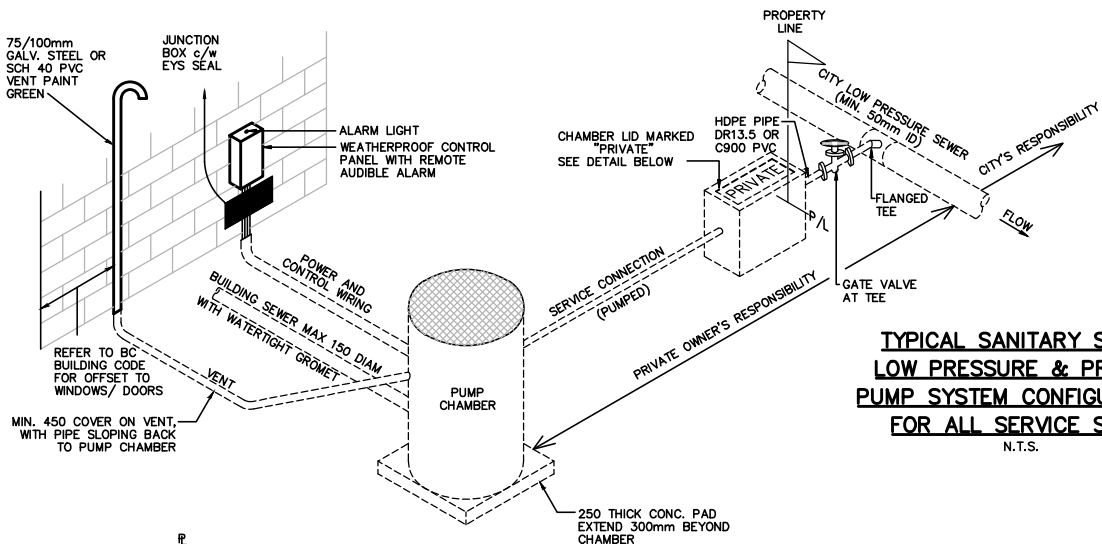

**TYPICAL SANITARY SEWER
LOW PRESSURE & PRIVATE
PUMP SYSTEM CONFIGURATION
FOR ALL SERVICE SIZES**

N.T.S.

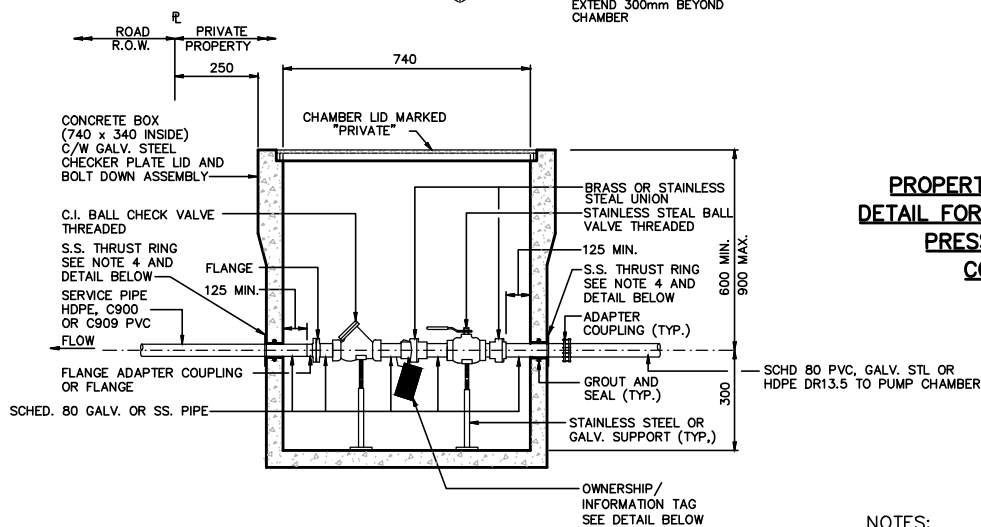

**PROPERTY LINE CHAMBER
DETAIL FOR UP TO 75mm LOW
PRESSURE SERVICE
CONNECTION**

N.T.S.

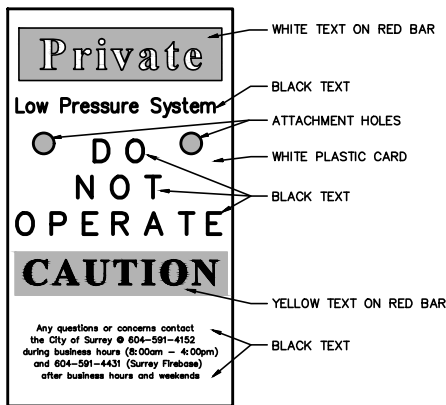

**OWNERSHIP/INFORMATION
TAG DETAIL**

N.T.S.

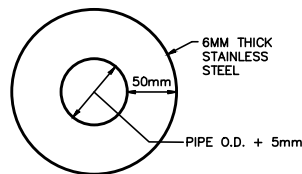

**THRUST RING
DETAIL**

N.T.S.

NOTES:

- (1) CONTROL PANEL MAY BE LOCATED INSIDE BUILDING OR ON POST ADJACENT TO PUMP CHAMBER IF APPROVED BY CITY.
- (2) VENT MAY BE CONNECTED TO BUILDING VENT SYSTEM OR LOCATED ADJACENT TO PUMP CHAMBER IF APPROVED BY CITY.
- (3) ALL PIPE SIZES REFER TO INSIDE DIAMETER (I.D.).
- (4) THRUST RING SLIPPED OVER PIPE AND HELD IN PLACE BY COUPLING OR FLANGE.
- (5) PROPERTY OWNER IS RESPONSIBLE FOR MAINTENANCE OF ALL SEWER CONNECTION COMPONENTS INCLUDING PIPE BETWEEN PROPERTY LINE AND THE CITY SEWER.
- (6) CHAMBER ACCESS IS TO BE UNOBSTRUCTED.
- (7) CITY STAFF OR AGENTS ARE ALLOWED UNRESTRICTED ACCESS TO CHAMBER.
- (8) SS TO BE GRADE 304 OR 316.

3	APRIL 2020	SCOTT NEUMAN
2	JANUARY 2016	ROBERT LEE
1	FEBRUARY 2007	
	Revision Date	Approved

All Dimensions Shown In Millimetres, Unless Otherwise Noted	
Title	PRIVATE PUMP SYSTEM CONFIGURATION UP TO 75mm

CITY OF SURREY
the future lives here.

SUPPLEMENTARY STANDARD DRAWINGS

Approved By :

APRIL 2020 G.M. Engineering

DRAWING NUMBER
SSD-S.3

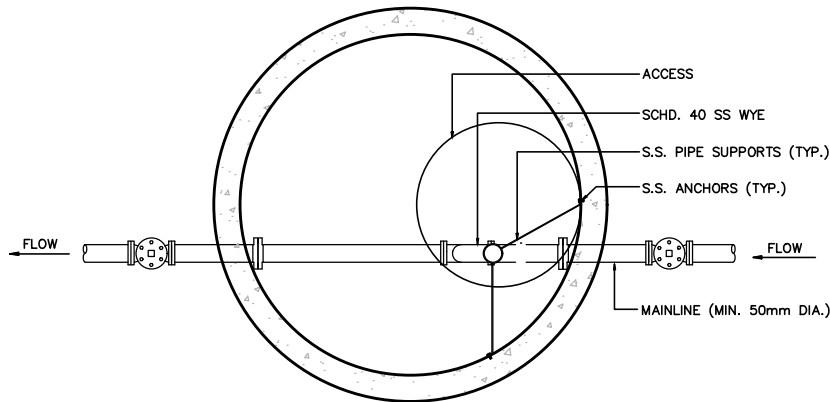

TYPICAL CLEANOUT

STD. 1200mm DIA. MANHOLE (FOR MAINLINES UP TO 100mm) & 1500mm DIA. MANHOLE (FOR MAINLINES 150mm OR LARGER) WITH 813mm DIA. FRAME AND COVER (3-PC. NON-LOCKING LID), CENTERED OVER MAINLINE RISER

3

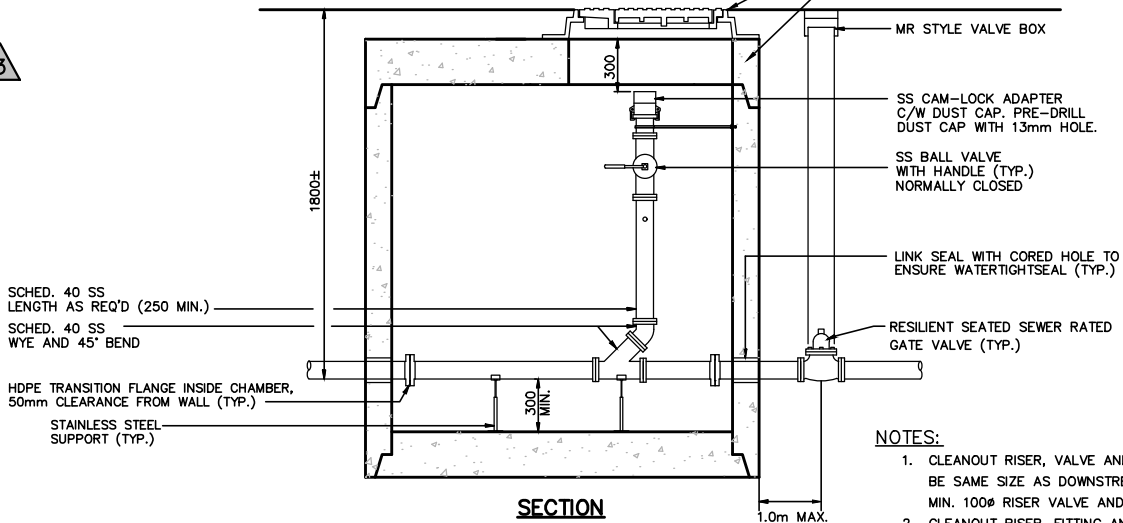

SECTION

NOTES:

1. CLEANOUT RISER, VALVE AND CAM-LOCK TO BE SAME SIZE AS DOWNSTREAM PIPE, WITH MIN. 100Ø RISER VALVE AND CAM-LOCK.
2. CLEANOUT RISER, FITTING AND VALVE DETAILS COMMON FOR ALL CLEANOUT TYPES.
3. ALL FITTINGS TO BE FLANGED. VICTAULIC COUPLINGS PERMITTED ON MAINLINE ONLY.
4. MINIMUM 1500mm DIA. MANHOLE REQUIRED FOR 100mm AND 50mm FORCEMAINS AS SHOWN. ADJUST AS REQUIRED FOR DIFFERENT SIZES.
5. SEE MMCD STANDARD MANHOLE DRAWING FOR RUNGS AND OTHER DETAILS. SEAL RISER JOINTS TO ENSURE WATERTIGHT.
6. DESIGN ENGINEER SHALL ENSURE ALL COMPONENTS FIT INSIDE MH AND IN COMPLIANCE WITH WCB REQUIREMENTS.
7. STAINLESS STEEL TO BE GRADE 304 OR 316

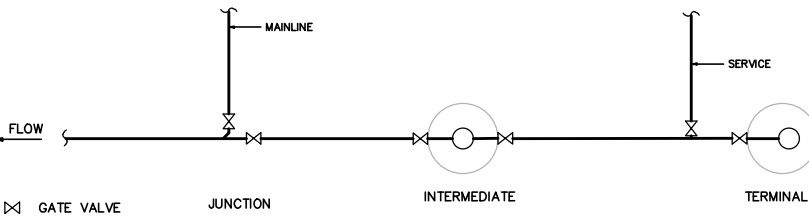

CLEANOUT TYPES

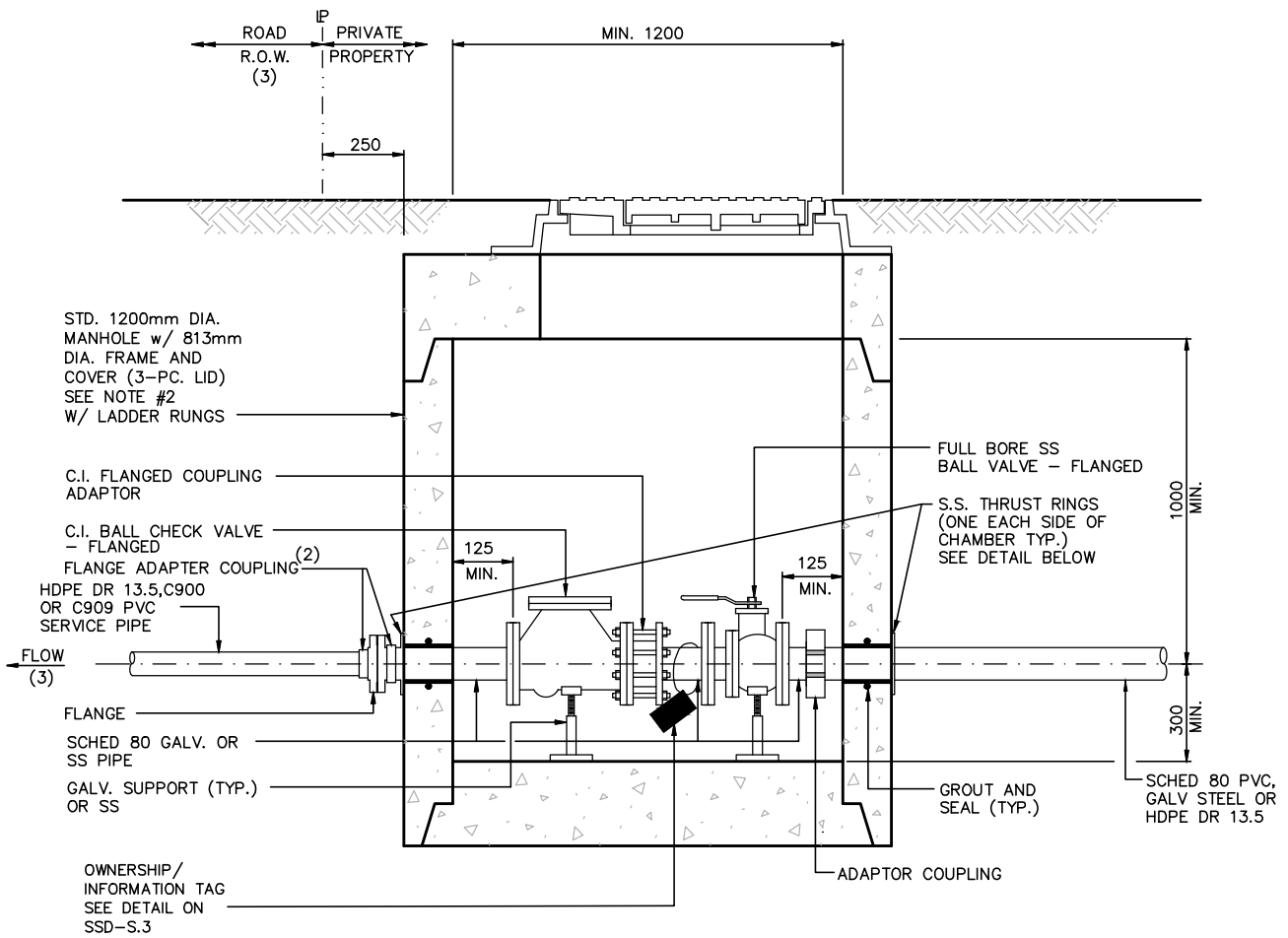

3	APRIL 2020	ROBERT LEE	All Dimensions Shown In Metres, Unless Otherwise Noted
2	JANUARY 2016	ROBERT LEE	
1	DECEMBER 2006		
	Revision Date	Approved	Title CLEANOUT MANHOLE FOR LOW PRESSURE SEWERS
			Approved By :
SUPPLEMENTARY STANDARD DRAWINGS			APRIL 2020 G.M. Engineering
			DRAWING NUMBER SSD-S.3.1



**PROPERTY LINE CHAMBER DETAIL
FOR 100mm AND LARGER**
N.T.S.

NOTES:

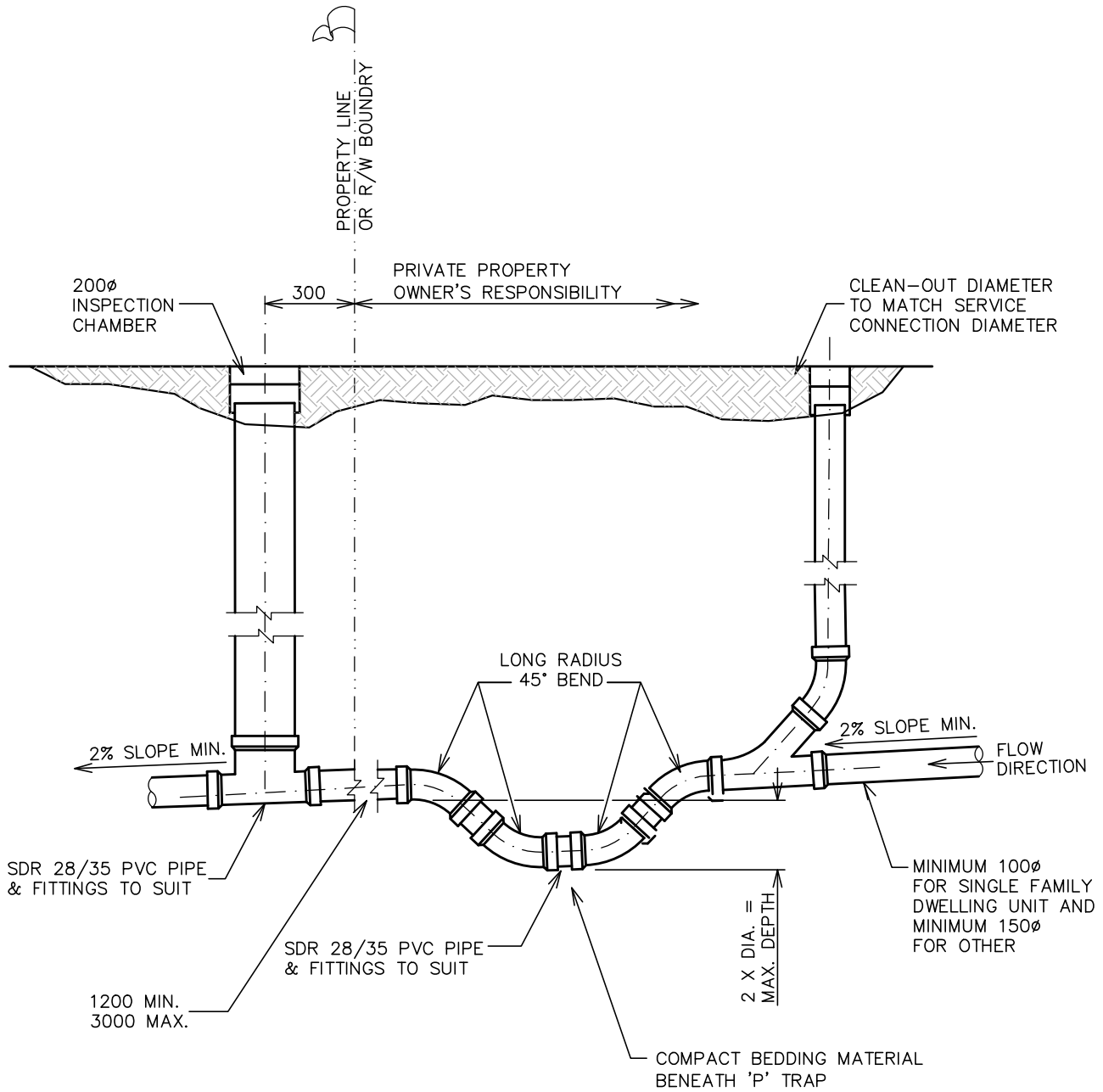

1. SS GRADE 304 OR 316.
2. ONLY REQUIRED FOR CONNECTING FLANGE TO PVC PIPE.
3. VALVE REQUIRED, ON SERVICE CONNECTION, AT MAIN LINE TEE/WYE.

3		All Dimensions Shown In Metres, Unless Otherwise Noted	
2	APRIL 2020	SCOTT NEUMAN	
1	JANUARY 2016	ROBERT LEE	Title TYPICAL LOW PRESSURE SEWER CONNECTION PROPERTY LINE CHAMBER, 100mm AND LARGER SERVICE
	Revision Date	Approved	
		SUPPLEMENTARY STANDARD DRAWINGS	Approved By :  APRIL 2020 G.M. Engineering
			DRAWING NUMBER SSD-S.3.2



SERVICE CONNECTION P-TRAP ON PRIVATE PROPERTY
(GUIDELINE ONLY – SLOPES LESS THAN 10%)

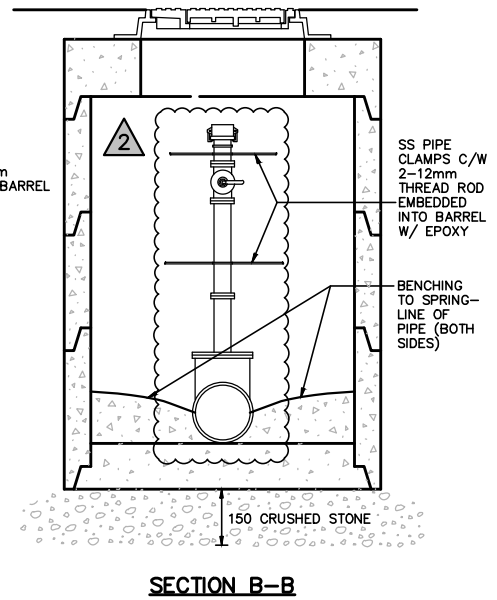
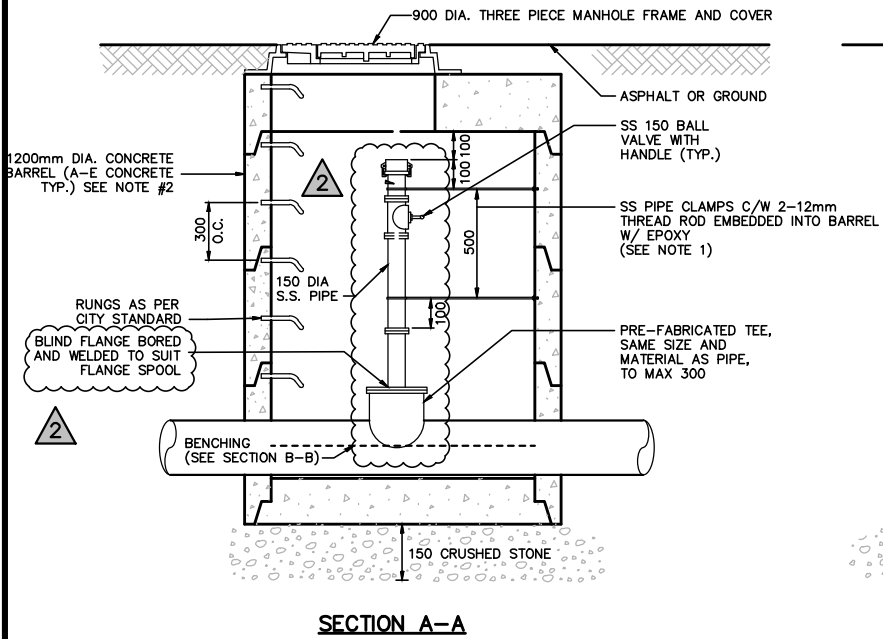
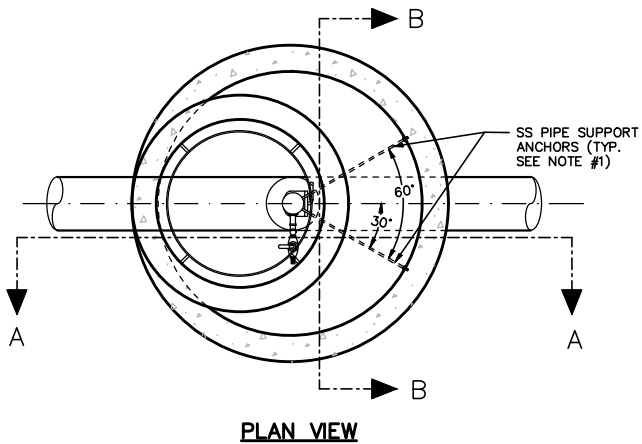

NOTES: 1) P-TRAP OFFSET FROM PL TO BE 1/3 HOUSE SET BACK DISTANCE, AND MIN 1200mm

3			All Dimensions Shown In Millimetres, Unless Otherwise Noted
2	APRIL 2020	SCOTT NEUMAN	
1	JANUARY 2016	ROBERT LEE	
	Revision Date	Approved	Title SERVICE CONNECTION P-TRAP PRIVATE PROPERTY
 CITY OF SURREY the future lives here.			Approved By :  APRIL 2020 G.M. Engineering
SUPPLEMENTARY STANDARD DRAWINGS			DRAWING NUMBER SSD-S.4



NOTES:

1. WHEN PLACING PIPE SUPPORT, CONSIDER MAINTENANCE ACCESS AND ADJUST LOCATIONS ACCORDINGLY.
2. ALL JOINTS TO BE SEALED TO MAKE MANHOLE WATER-TIGHT.
3. DESIGN ENGINEER TO ENSURE COMPONENTS FIT INSIDE THE MANHOLE DEPTH.

3			All Dimensions Shown In Millimetres, Unless Otherwise Noted
2	APRIL 2020	ROBERT LEE	
1	JANUARY 2016	ROBERT LEE	Title MANHOLE FOR FORCEMAINS AND PRESSURE SEWERS
	Revision Date	Approved	
			Approved By :  APRIL 2020 G.M. Engineering
SUPPLEMENTARY STANDARD DRAWINGS			

INSPECTION BY GVS & DD OR
CITY AS APPLICABLE REQUIRED

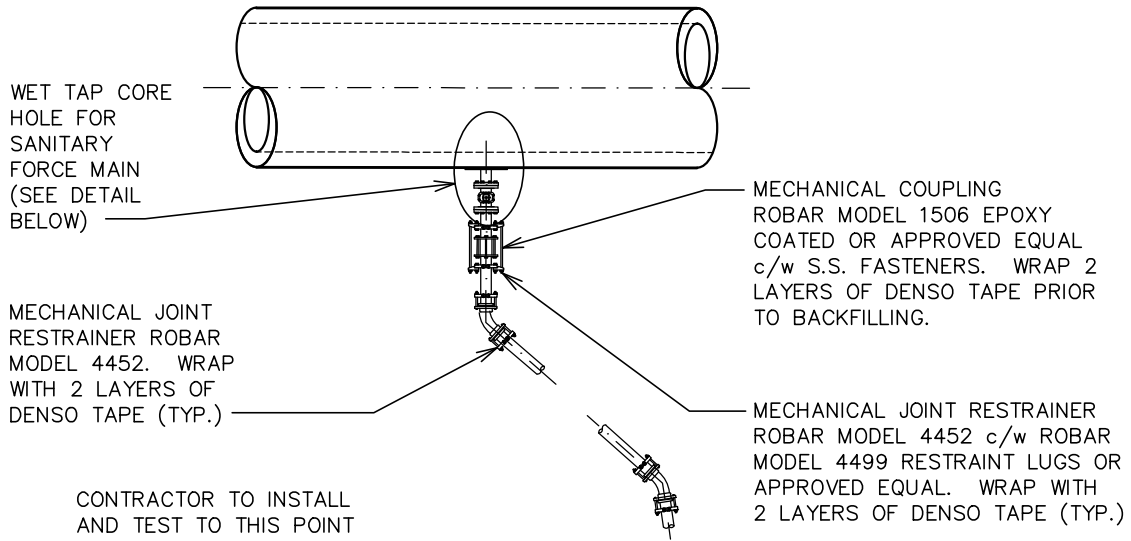

DETAIL AT INTERCEPTOR OR TRUNK

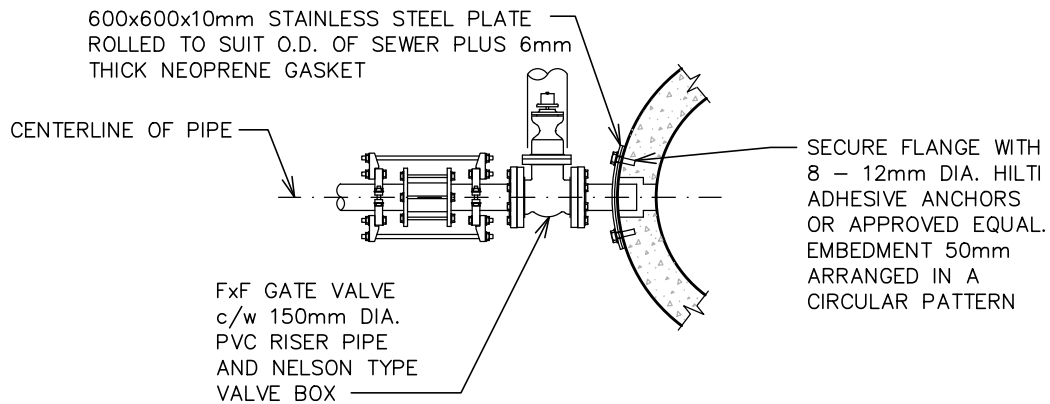

WET TAP CONNECTION DETAIL - SECTION

3			All Dimensions Shown In Metres, Unless Otherwise Noted
2	APRIL 2020	SCOTT NEUMAN	
1	JANUARY 2016	ROBERT LEE	Title TYPICAL FORCEMAIN CONNECTION WET TAP CORING
	Revision Date	Approved	
			Approved By : APRIL 2020 G.M. Engineering
SUPPLEMENTARY STANDARD DRAWINGS			DRAWING NUMBER SSD-S.6

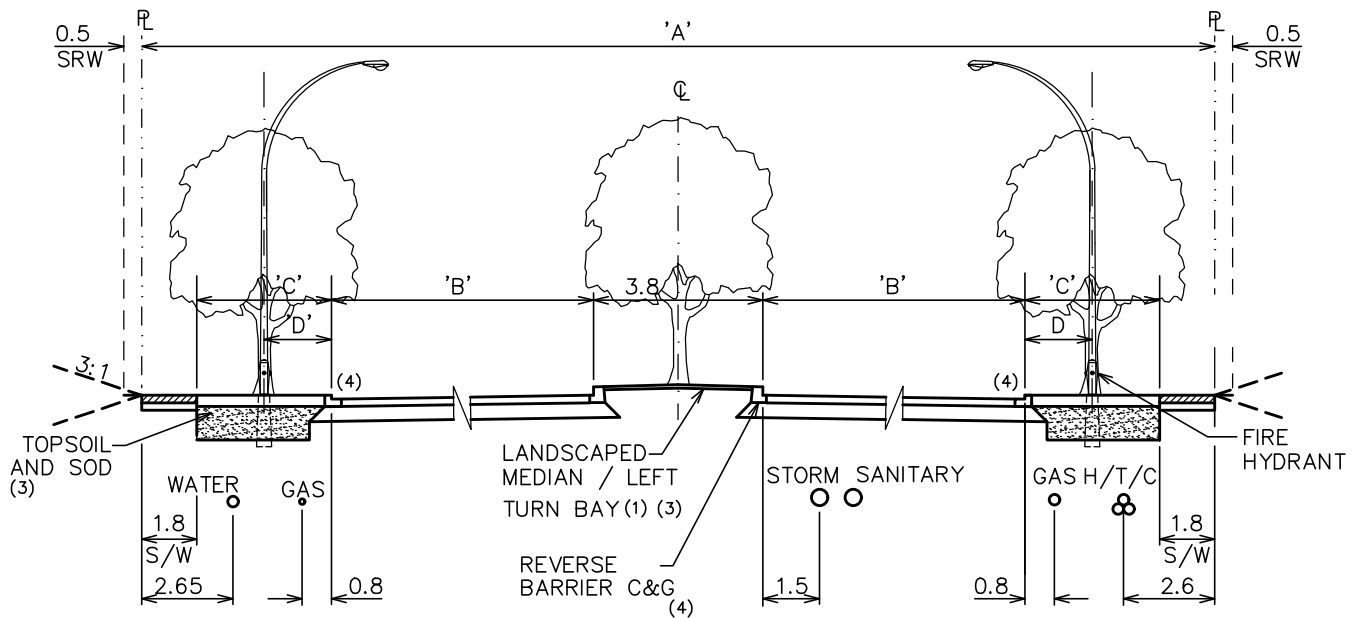

ROAD ALLOWANCE	PAVEMENT	UTILITY STRIP	OFFSET FROM CURB	LANE CONFIGURATION
'A'	'B'	'C'	'D'	WITHIN 'B' (*)
27	8.1	1.7	1.0	1.8-3.0-3.3
30	8.1	3.2	1.0	1.8-3.0-3.3
34	11.1	1.9	1.0	1.8-3.0-3.3-3.3
37	11.6	3.2	1.0	1.8-3.0-3.3-3.3

*AS ACCEPTED BY THE CITY ENGINEER:

- BIKE LANES CAN BE CONVERTED TO PROTECTED BIKE LANES RANGING IN WIDTH BETWEEN 1.5m TO 1.8m OR COMBINED WITH THE SIDEWALK TO CREATE A MULTI-USE PATHWAY WITH A WIDTH NO GREATER THAN 3.0m.
- TRAVEL LANES CAN RANGE BETWEEN 3.0-3.3m AND LEFT TURN LANES CAN RANGE FROM 3.0-3.2m.
- IN CONSTRAINED LOCATIONS BOULEVARD WIDTHS CAN BE REDUCED TO 1.2m.

NOTES:

- LANDSCAPED MEDIAN AS PER SSD-R.16, LEFT TURN BAY AS PER SSD-R.15
- FOR 70 km/h DESIGN SPEED OR GREATER USE MMCD C-6 MEDIAN CURB.
- 600mm GROWING MEDIUM
- CURB AND GUTTER TO BE BIKE FRIENDLY BARRIER CURB AS PER SSD-D.9, UNLESS APPROVED OTHERWISE.

3	APRIL 2020	SCOTT NEUMAN
2	JANUARY 2016	JAIME BOAN
1	JANUARY 2004	KOK KUEN LI
	Revision Date	Approved

All Dimensions Shown In Metres, Unless Otherwise Noted	
Title ROAD SECTIONS, ARTERIAL ROADS	



SUPPLEMENTARY
STANDARD
DRAWINGS

Approved By :

APRIL 2020

G.M. Engineering

DRAWING NUMBER

SSD-R.1

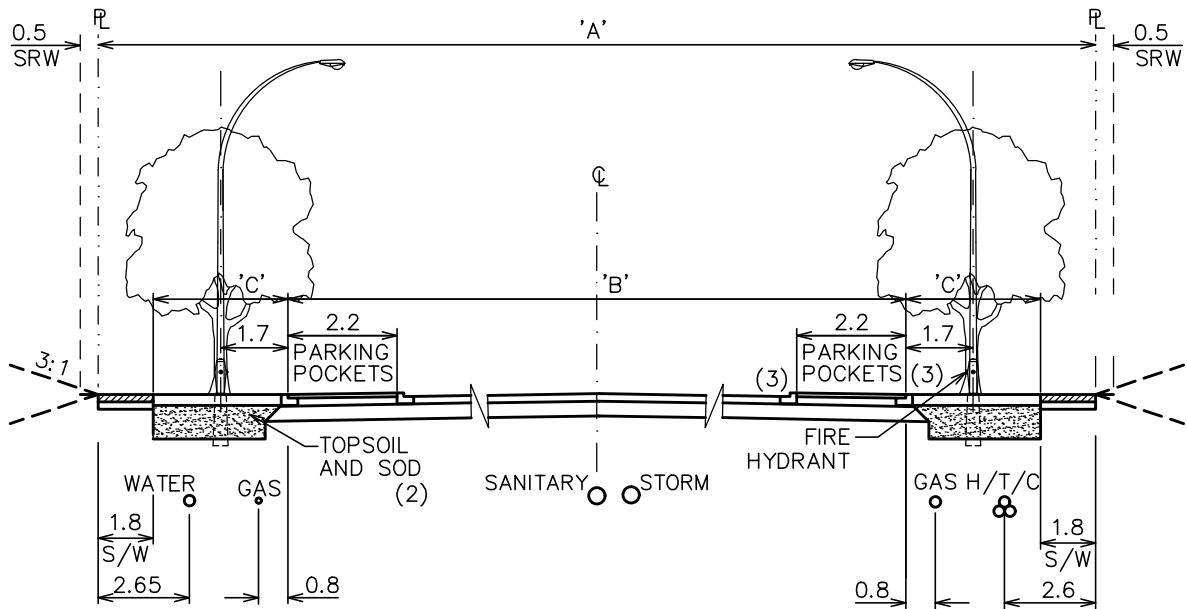

ROAD ALLOWANCE	PAVEMENT	UTILITY STRIP	LANE CONFIGURATION
'A'	'B'	'C'	WITHIN 'B' (*)
22	12.2	3.1	1.8-3.2-3.2-1.8-2.2
23 ⁽¹⁾	14.0	2.3	(2.2-1.8-3.0)x2
24	14.0	3.2	(2.2-1.8-3.0)x2

*AS ACCEPTED BY THE CITY ENGINEER:

- BIKE LANES CAN BE CONVERTED TO PROTECTED BIKE LANES RANGING IN WIDTH BETWEEN 1.5m TO 1.8m OR COMBINED WITH THE SIDEWALK TO CREATE A MULTI-USE PATHWAY WITH A WIDTH NO GREATER THAN 3.0m.
- TRAVEL LANES CAN RANGE BETWEEN 3.0-3.3m AND LEFT TURN LANES CAN RANGE FROM 3.0-3.2m.
- IN CONSTRAINED LOCATIONS BOULEVARD WIDTHS CAN BE REDUCED TO 1.2m.



NOTES:

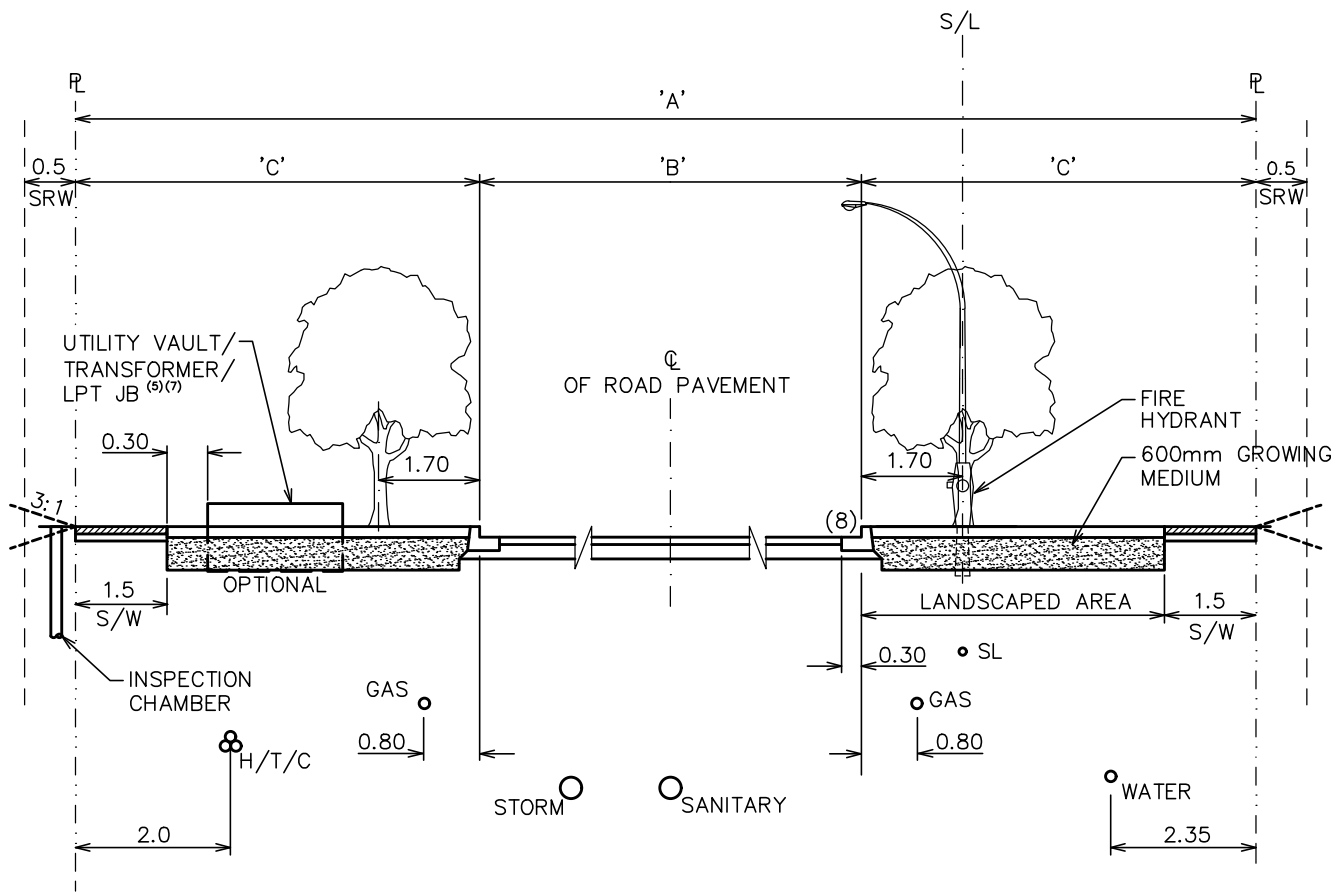

- WHEN COMPLETING REMAINING HALF OF EXISTING URBAN FOREST SECTION, 0.9m OFFSET PAVEMENT CENTERLINE AND 2.3m UTILITY STRIP IS REQUIRED.
- 600mm GROWING MEDIUM..
- CURB AND GUTTER TO BE BIKE FRIENDLY BARRIER CURB AS PER SSD-D.9, UNLESS APPROVED OTHERWISE.

3	APRIL 2020	SCOTT NEUMAN	All Dimensions Shown In Metres, Unless Otherwise Noted
	JANUARY 2016	JAIME BOAN	
	JANUARY 2004	KOK KUEN LI	
	Revision Date	Approved	Title ROAD SECTIONS, COLLECTOR ROADS
		SUPPLEMENTARY STANDARD DRAWINGS	Approved By : APRIL 2020 G.M. Engineering
			DRAWING NUMBER SSD-R.2



ROAD ALLOWANCE	PAVEMENT	BOULEVARD
A	B	C
15.5	6.6 ⁽³⁾	4.45 ⁽⁶⁾
17.0	8.0	4.50
18.0	8.5	4.75
20.0	10.5	4.75
20.0	11.0	4.50

- NOTES:
1. TO DETERMINE APPROPRIATE CROSS SECTION REFER TO SECTION 2.2 OF THE DESIGN CRITERIA.
 2. STREETLIGHTS STAGGERED ON BOTH SIDES FOR PAVEMENT WIDTH GREATER THAN 8.5m, WITH PRIMARY DUCTING OPPOSITE HYDRO/TEL/CABLE.
 3. DRIVEWAYS ON OPPOSITE SIDE OF STREET MUST ALIGN.
 4. FOR PARKING CURB EXTENSIONS, REFER TO SSD-R28.3
 5. TRANSFORMER MUST BE 6.1m FROM ANY COMBUSTIBLE SURFACE OR CONCRETE FENCE IS REQUIRED.
 6. SIDEWALK ON ONE SIDE ONLY.
 7. UTILITY VAULT/TRANSFORMER/LPT/JUNCTION BOX SHALL BE MIN OF 0.3m OFFSET FROM SIDEWALK.
 8. CURB AND GUTTER TO BE NARROW BASE BARRIER CURB AS PER MMCD DWG C4.

3		All Dimensions Shown In Metres, Unless Otherwise Noted
2	APRIL 2020 SCOTT NEUMAN	
1	JANUARY 2016 JAIME BOAN	
	Revision Date Approved	Title ROAD SECTIONS, LOCAL ROADS
 SUPPLEMENTARY STANDARD DRAWINGS		Approved By :  APRIL 2020 G.M. Engineering
		DRAWING NUMBER SSD-R.3

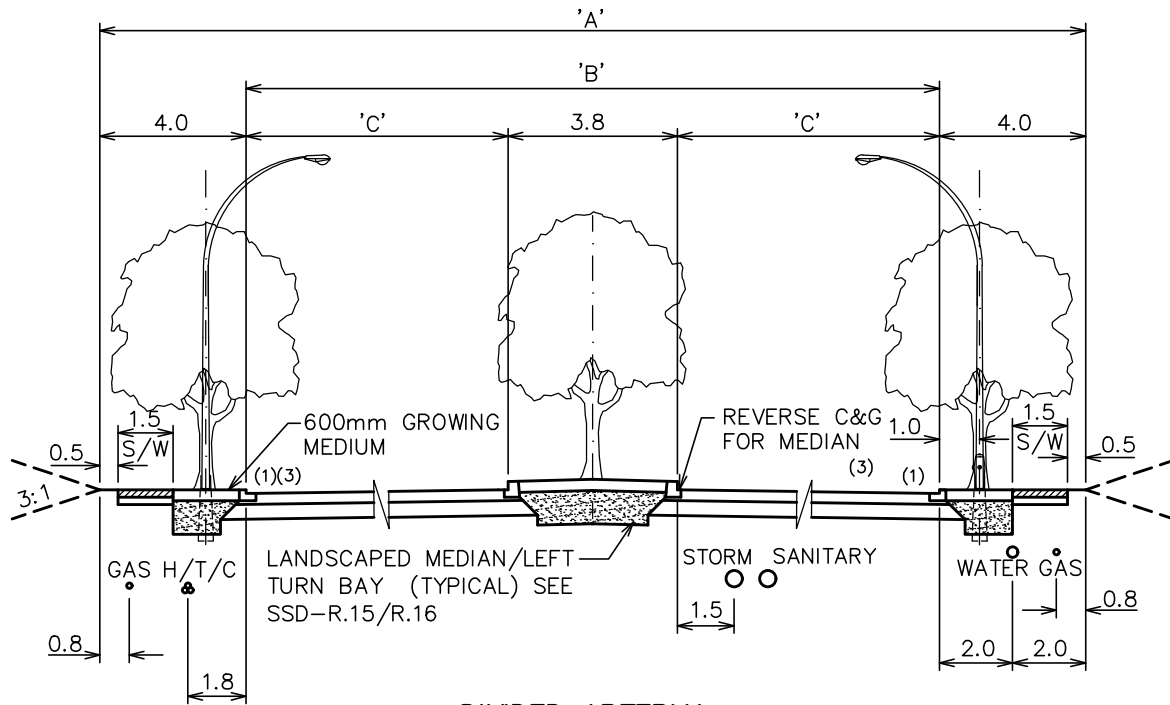

DIVIDED ARTERIAL

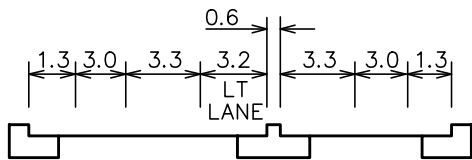

4 LANE DETAIL

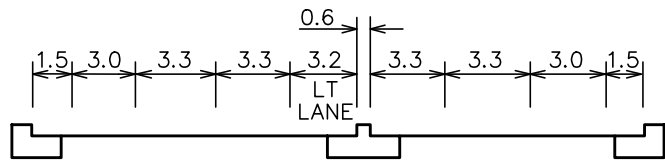

6 LANE DETAIL

TRAVEL LANES (*)	ROAD ALLOWANCE	CURB TO CURB	PAVEMENT
	A	B	C
4 LANE	27	19	7.6
6 LANE	34	26	11.1

*AS ACCEPTED BY THE CITY ENGINEER:



- BIKE LANES CAN BE CONVERTED TO PROTECTED BIKE LANES RANGING IN WIDTH BETWEEN 1.5m TO 1.8m OR COMBINED WITH THE SIDEWALK TO CREATE A MULTI-USE PATHWAY WITH A WIDTH NO GREATER THAN 3.0m.
- TRAVEL LANES CAN RANGE BETWEEN 3.0-3.3m AND LEFT TURN LANES CAN RANGE FROM 3.0-3.2m.
- IN CONSTRAINED LOCATIONS BOULEVARD WIDTHS CAN BE REDUCED TO 1.2m.

NOTES:

- SIDE INLET CATCH BASINS REQUIRED WITH BIKE FRIENDLY BARRIER CURB AS PER SSD-D.9
- FOR 70 km/h DESIGN SPEED OR GREATER USE MMCD C-6 MEDIAN CURB.
- CURB AND GUTTER TO BE BIKE FRIENDLY BARRIER CURB AS PER SSD-D.9, UNLESS APPROVED OTHERWISE

3	APRIL 2020	SCOTT NEUMAN
2	JANUARY 2016	JAIME BOAN
1	JANUARY 2004	KOK KUEN LI
	Revision Date	Approved

All Dimensions Shown In Metres, Unless Otherwise Noted	
Title ROAD SECTIONS, URBAN FOREST ARTERIAL ROADS	

SUPPLEMENTARY STANDARD DRAWINGS

Approved By :

APRIL 2020 G.M. Engineering

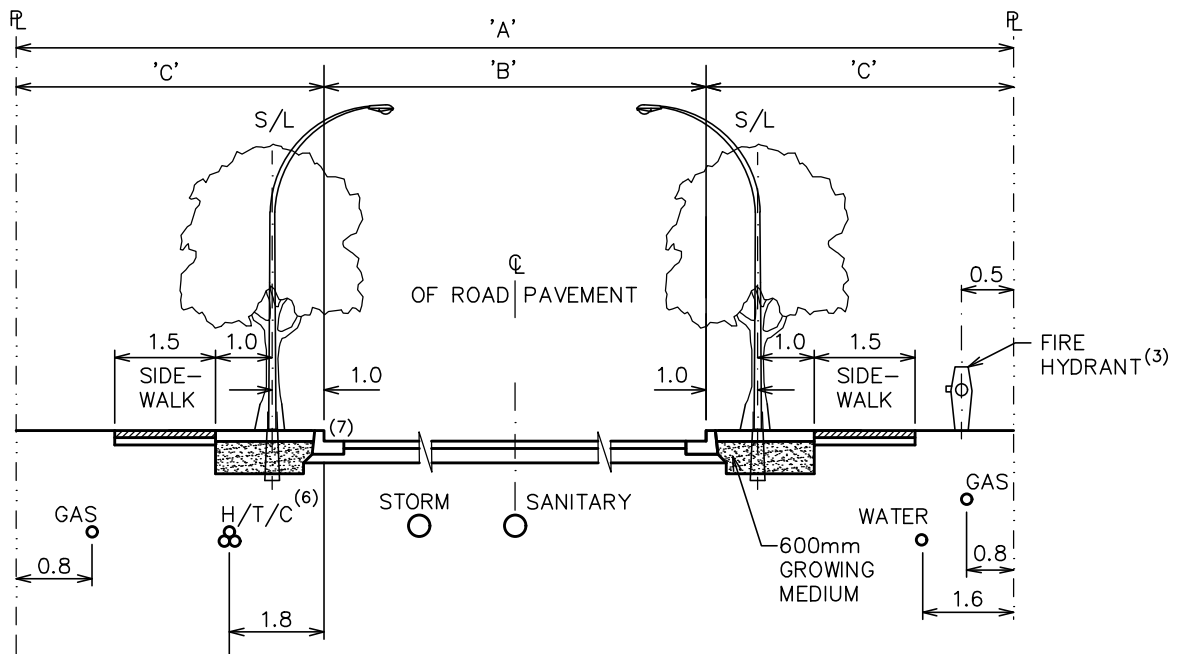

DRAWING NUMBER
SSD-R.4



ROAD ALLOWANCE	PAVEMENT	BOULEVARD
A	B	C
16.5	8	4.25
20	8.5	5.75
20	11	4.5
22	12.2	4.9
24	14	5

NOTES:

1. TO DETERMINE APPROPRIATE CROSS SECTION, REFER TO SECTION 2.2 OF THE DESIGN CRITERIA.
2. STREETLIGHTS STAGGERED ON BOTH SIDES FOR PAVEMENT WIDTH GREATER THAN 8.5m, WITH PRIMARY DUCTING OPPOSITE HYDRO/TEL/CABLE.
3. WHERE THE FIRE HYDRANT IS IN THE WAY OF THE SIDEWALK, THE HYDRANT LOCATION SHALL BE SHIFTED TO THE SAME ALIGNMENT AS THE STREET LIGHT.
4. FOR CURB EXTENSIONS, REFER TO SSD-R.28.3.
5. MEANDER SIDEWALK AROUND EXISTING UTILITY POLES/PLANTS AT 3m RADIUS.
6. HYDRO/TEL/CABLE ARE NOT TO BE LOCATED UNDER SIDEWALK.
7. CURB AND GUTTER TO BE NARROW BASE BARRIER CURB AS PER MMCD DWG C4

3		All Dimensions Shown In Metres, Unless Otherwise Noted
2	APRIL 2020 SCOTT NEUMAN	
1	JANUARY 2016 JAIME BOAN	
	Revision Date Approved	Title ROAD SECTIONS, URBAN FOREST
 <p>CITY OF SURREY the future lives here.</p>		SUPPLEMENTARY STANDARD DRAWINGS Approved By :  APRIL 2020 G.M. Engineering
		DRAWING NUMBER SSD-R.5

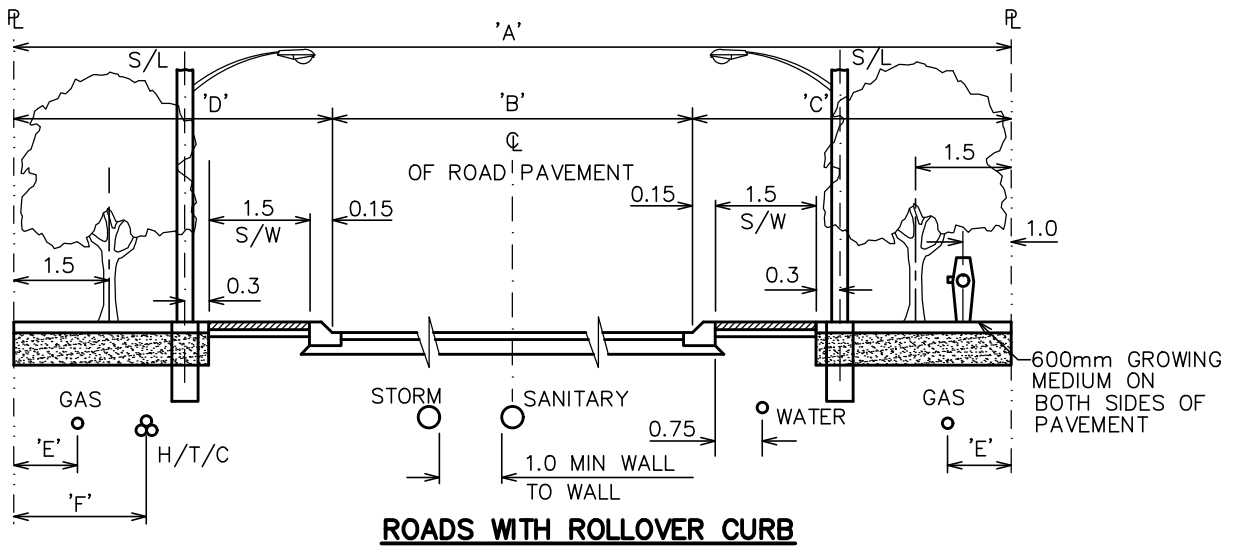
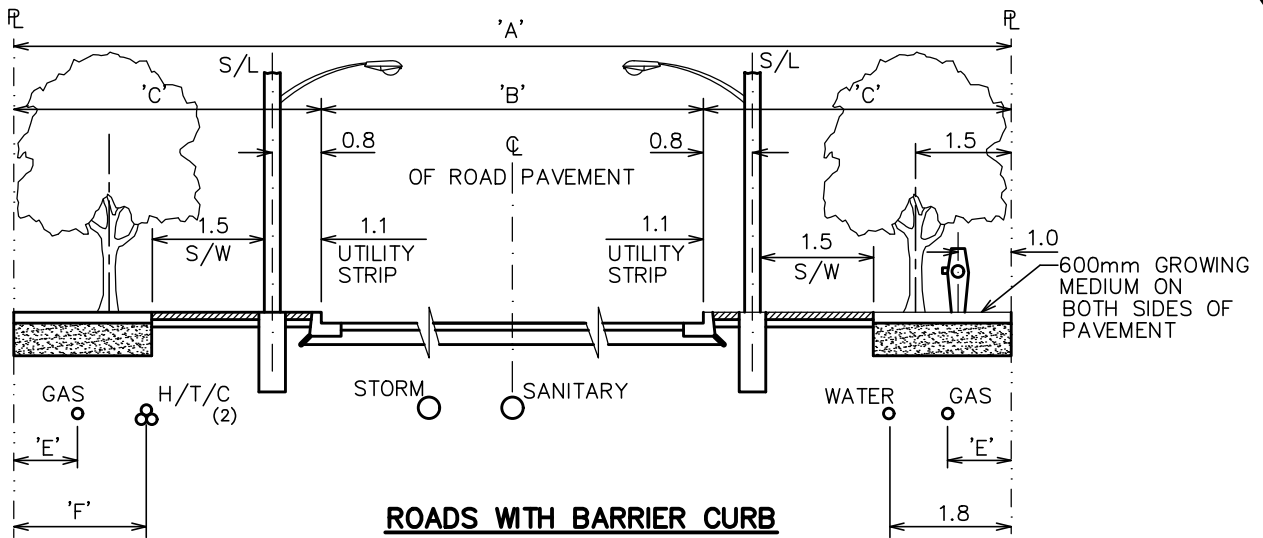

ROAD ALLOWANCE	PAVEMENT	No. OF S/WALK	BOULEVARD		GAS	H/T/C
			C	D		
16.5	8	1	4.25	4.25	0.8	1.3
20	8.5	2	5.75	5.75	0.8	2
20	11	2	4.5	4.5	0.8	1.3
22	12.2	2	4.9	4.9	0.8	2

NOTES:

1. STREETLIGHTS STAGGERED ON BOTH SIDES FOR PAVEMENT WIDTH GREATER THAN 8.5m, WITH PRIMARY DUCTING OPPOSITE HYDRO/TEL/CABLE.
2. HYDRO/TEL/CABLE BOXES ARE NOT TO BE LOCATED UNDER SIDEWALK.

3	APRIL 2020	SCOTT NEUMAN	All Dimensions Shown In Metres, Unless Otherwise Noted
2	JANUARY 2016	JAIME BOAN	
1	MARCH 2002		
Revision Date			Approved
CITY OF SURREY the future lives here.			ROAD SECTIONS, HISTORICAL
			Approved By : APRIL 2020
SUPPLEMENTARY STANDARD DRAWINGS			G.M. Engineering

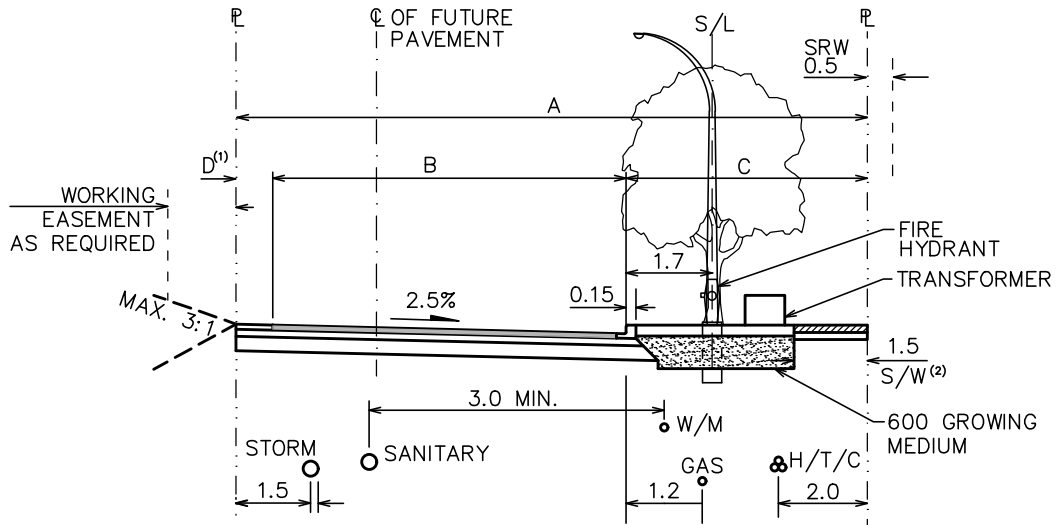

STANDARD

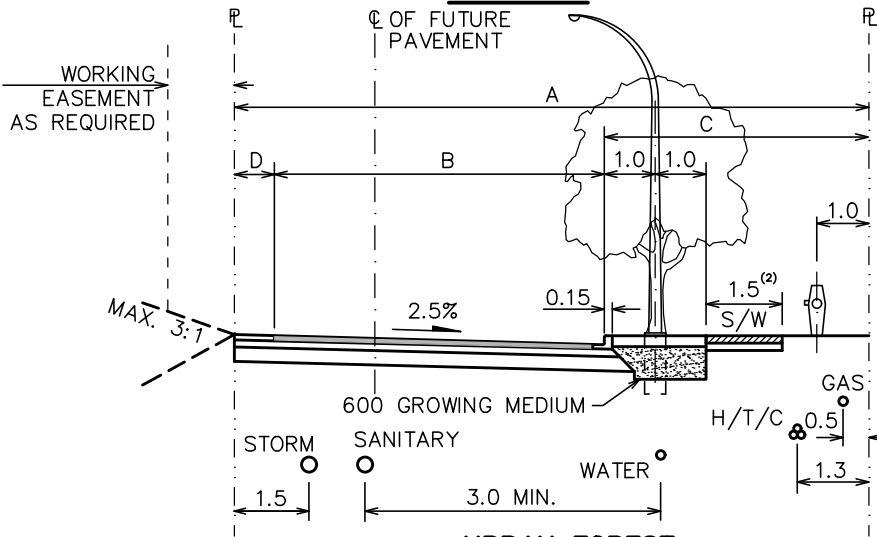

URBAN FOREST

		ROAD ALLOWANCE	PAVEMENT	BOULEVARD	SHOULDER
ROAD CLASS	ADJACENT LAND USE	A	B	C	D
LOCAL	RESIDENTIAL	11.5	6.0	4.75	0.75
LOCAL	RESIDENTIAL-URBAN FOREST	11.5	6.0	5.0	0.5
LOCAL	INDUSTRIAL/COMMERCIAL	13.5	8.0	4.5	1.0
COLLECTOR	RESIDENTIAL	12.0	6.0	5.0 ⁽²⁾	1.0
COLLECTOR	INDUSTRIAL/COMMERCIAL	13.5	8.0	5.0 ⁽²⁾	0.5

NOTES:

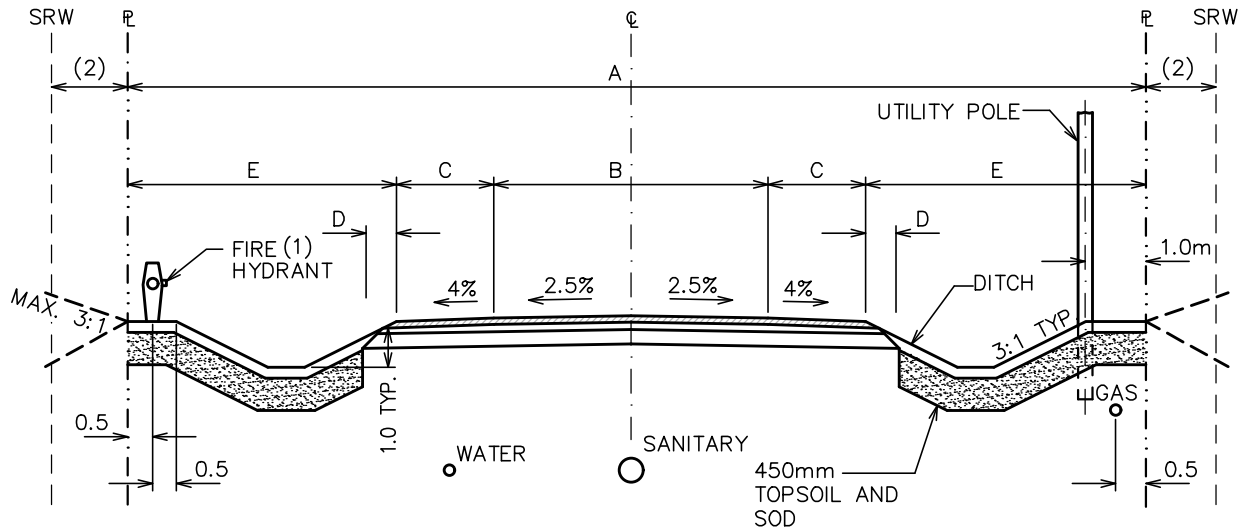

1. HALF ROAD SHALL REFLECT THE ULTIMATE ROAD CROSS SECTION.
2. 1.8m SIDEWALK FOR COLLECTOR.

3	APRIL 2020	SCOTT NEUMAN	All Dimensions Shown In Metres, Unless Otherwise Noted
2	JANUARY 2016	JAIME BOAN	
1	FEBRUARY 2002		
Revision Date		Approved	Title ROAD SECTIONS, HALF ROAD
		SUPPLEMENTARY STANDARD DRAWINGS	Approved By : APRIL 2020 G.M. Engineering
			DRAWING NUMBER SSD-R.7



	ROAD ALLOWANCE	PAVEMENT	PAVED ⁽³⁾ SHOULDER	GRAVEL SHOULDER ROUNDING	DITCH SWALE
ROAD CLASS	A	B	C	D	E
LOCAL	20	6.0	1.5	0.5	5.0
COLLECTOR	24	6.6	2.0	0.5	6.2
INT. ARTERIAL	22	6.6	2.0	0.5	5.2
ULT. ARTERIAL (4LANE) ⁽²⁾	30	20	1.2	0.5	3.3
ULT. ARTERIAL (6LANE) ⁽²⁾	37	27	1.2	0.5	3.3

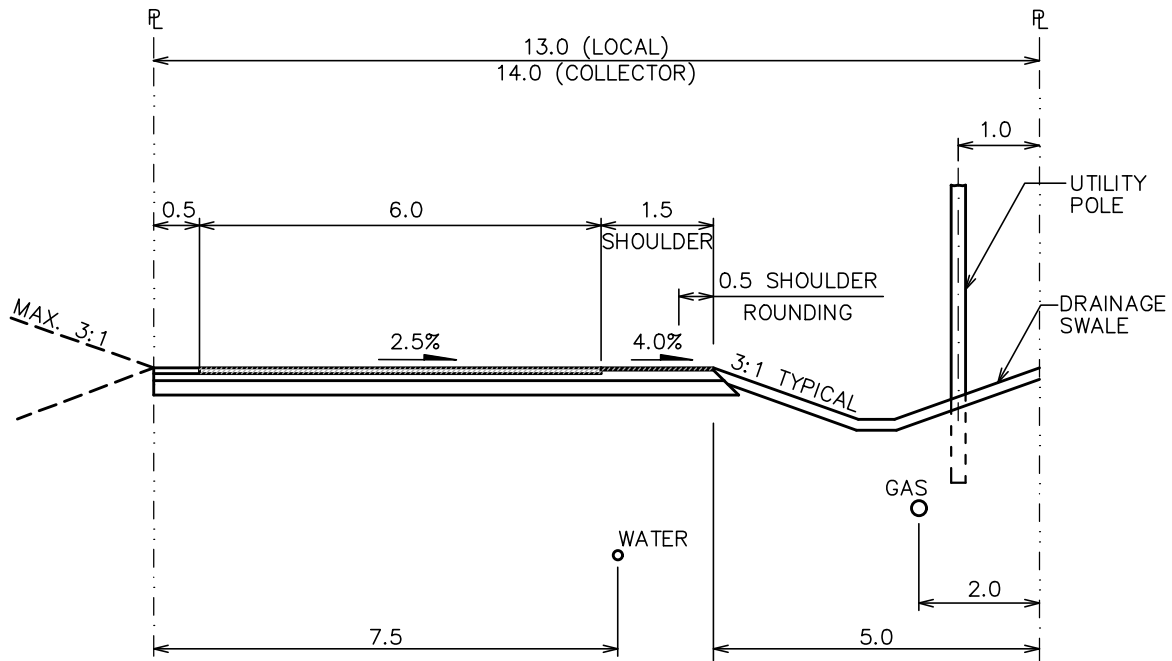

- NOTES: (1) THE LOCATION OF THE FIRE HYDRANT FROM THE PROPERTY LINE CAN BE LESS IF SPACE DOES NOT PERMIT. VEHICLE ACCESS SHOULD BE PROVIDED IF THE DITCH DEPTH EXCEEDS 0.7m.
- (2) ADDITIONAL SRW AS REQUIRED FOR DITCH/SWALE.
- (3) ADDITIONAL 0.75m WIDTH WOULD BE ADDED TO "C" IF ROADSIDE BARRIER IS REQUIRED.

3		All Dimensions Shown In Metres, Unless Otherwise Noted
2	APRIL 2020 SCOTT NEUMAN	
1	JANUARY 2016 JAIME BOAN	
	Revision Date Approved	Title ROAD SECTIONS, RURAL ROADS
 SUPPLEMENTARY STANDARD DRAWINGS		Approved By :  APRIL 2020 G.M. Engineering
		DRAWING NUMBER SSD-R.8



NOTES:

1. FOR COLLECTOR ROADS, PAVEMENT WIDTH IS INCREASED TO 7.0m AND ROAD ALLOWANCE INCREASED TO 14.0m.
2. DRAINAGE SWALE TO BE HYDROSEEDED.

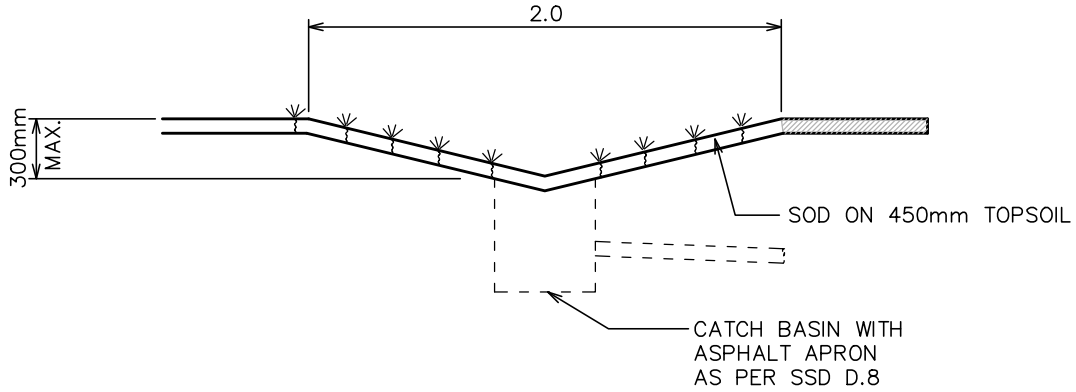

3		All Dimensions Shown In Metres, Unless Otherwise Noted
2	APRIL 2020 SCOTT NEUMAN	
1	JANUARY 2016 JAIME BOAN	
	Revision Date Approved	Title ROAD SECTIONS, RURAL HALF ROAD
 <p style="font-size: small;">the future lives here.</p>		<p style="text-align: center;">SUPPLEMENTARY STANDARD DRAWINGS</p> <p>Approved By : </p> <p style="text-align: center;">APRIL 2020 G.M. Engineering</p>
		DRAWING NUMBER SSD-R.9

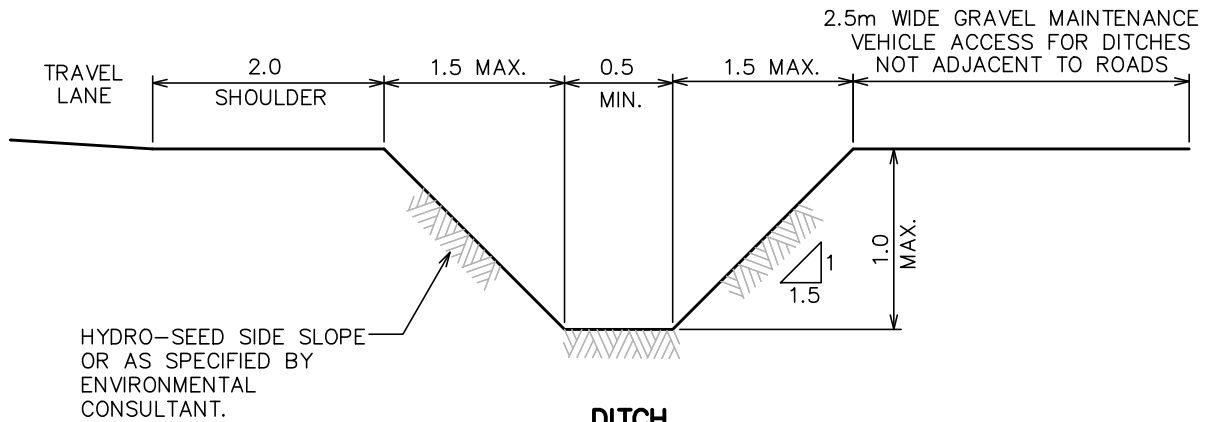

SODDED SWALE



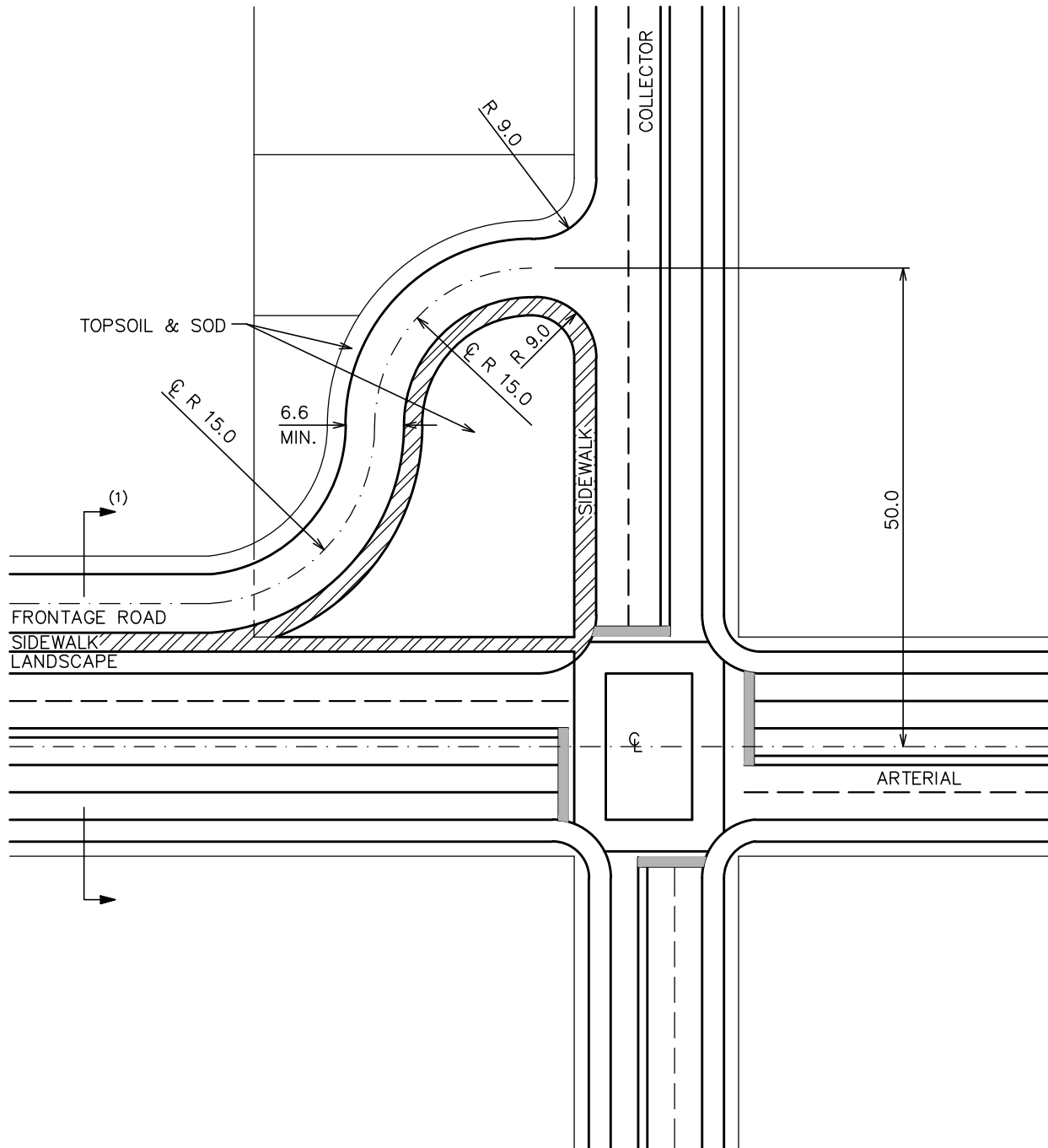

DITCH

3			All Dimensions Shown In Metres, Unless Otherwise Noted
2	APRIL 2020	SCOTT NEUMAN	
1	JANUARY 2016	CAROLYN BARON	Title
	Revision Date	Approved	ROAD DRAINAGE FOR ROADS WITHOUT CURBS
 <p>CITY OF SURREY the future lives here.</p>			Approved By :  APRIL 2020 G.M. Engineering
SUPPLEMENTARY STANDARD DRAWINGS			DRAWING NUMBER SSD-R.10



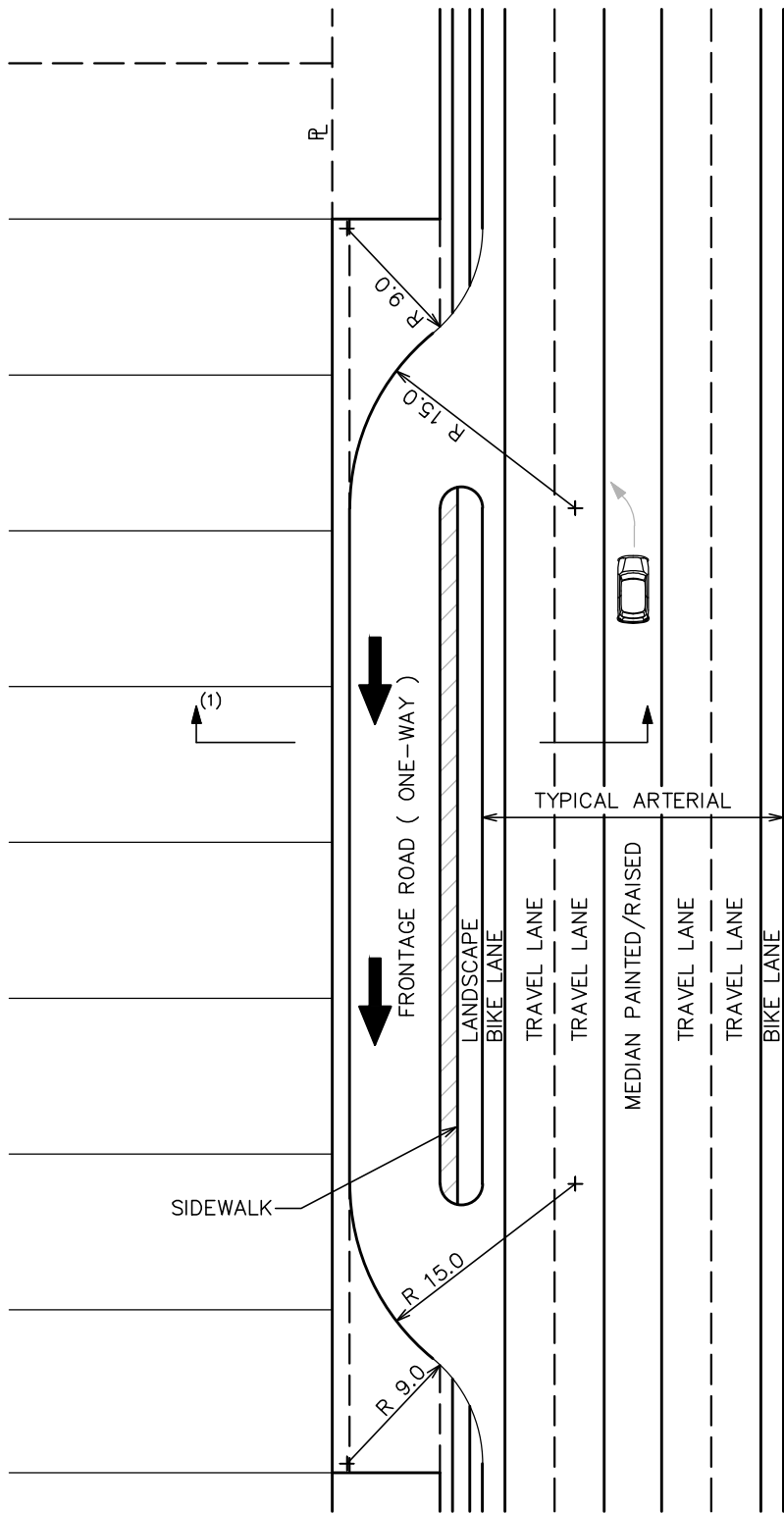

- NOTES:
 1. FOR CROSS SECTION REFER TO SSD-R.11.2.

3			All Dimensions Shown In Metres, Unless Otherwise Noted
2	APRIL 2020	SCOTT NEUMAN	
1	JANUARY 2016	JAIME BOAN	
	Revision Date	Approved	Title FRONTAGE ROADS, TYPICAL COLLECTOR ROAD ACCESS
 CITY OF SURREY the future lives here.			Approved By :  APRIL 2020 G.M. Engineering
SUPPLEMENTARY STANDARD DRAWINGS			DRAWING NUMBER SSD-R.11



NOTES:
 1. FOR CROSS SECTION REFER TO SSD-R.11.2

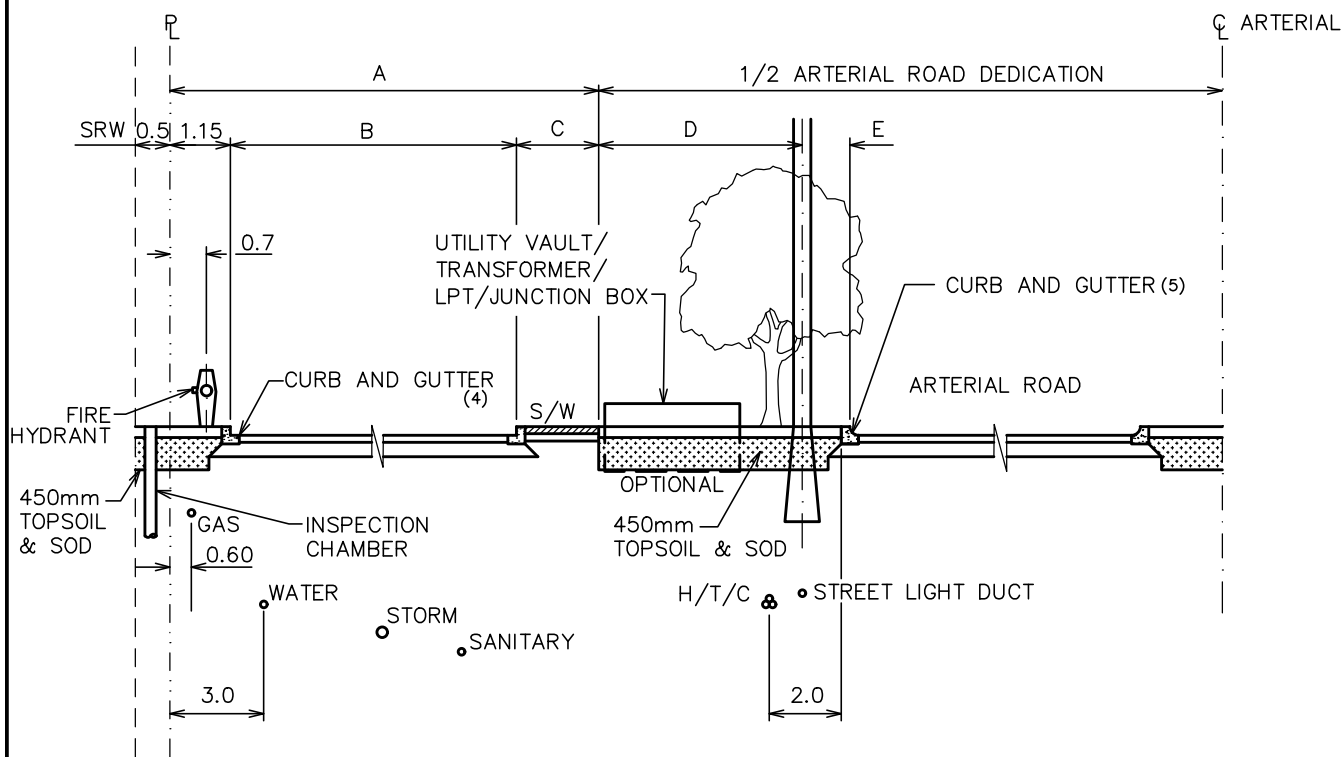

3			All Dimensions Shown In Metres, Unless Otherwise Noted
2	APRIL 2020	SCOTT NEUMAN	
1	JANUARY 2016	JAIME BOAN	Title FRONTAGE ROADS TYPICAL INTERIM ACCESS
	Revision Date	Approved	
 CITY OF SURREY the future lives here.			Approved By :  APRIL 2020 G.M. Engineering
SUPPLEMENTARY STANDARD DRAWINGS			DRAWING NUMBER SSD-R.11.1



	FRONTAGE ROAD ALLOWANCE	PAVEMENT	S/W & CURB	LANDSCAPE	S/L OFFSET
	A	B	C	D	E
URBAN FOREST ARTERIAL	8.8	6.0	1.65	3.0	1.0
ARTERIAL	9.1	6.0	1.95	3.2	1.7
URBAN FOREST ARTERIAL	11.3	8.5	1.65	3.0	1.0
ARTERIAL	11.6	8.5	1.95	3.2	1.7

NOTES:

- FRONTAGE ROADS ULTIMATELY SERVICING MORE THAN 50 LOTS OR UNITS, OR COMMERCIAL/INDUSTRIAL PROPERTIES, OR IN EXCESS OF 200m, SHALL HAVE A PAVEMENT WIDTH OF 8.5m.
- EXTRUDED CONCRETE CURB REQUIRED FOR INTERIM ARTERIAL WIDENED ROADS, WITH ILLUMINATION REQUIREMENTS DESIGNED FOR ULTIMATE ARTERIAL WIDENING.
- PARKING ADJACENT TO PROPERTY LINE FOR 6.0m PAVEMENT.
- CURB AND GUTTER TO BE NARROW BASE BARRIER CURB AS PER MMCD DWG C4
- CURB AND GUTTER TO BE BIKE FRIENDLY BARRIER CURB AS PER SSD-D.9, UNLESS APPROVED OTHERWISE

3			All Dimensions Shown In Metres, Unless Otherwise Noted
2	APRIL 2020	SCOTT NEUMAN	
1	JANUARY 2016	JAIME BOAN	
	Revision Date	Approved	Title ROAD SECTIONS, FRONTAGE ROAD
 CITY OF SURREY the future lives here.			Approved By :  APRIL 2020 G.M. Engineering
SUPPLEMENTARY STANDARD DRAWINGS			DRAWING NUMBER SSD-R.11.2

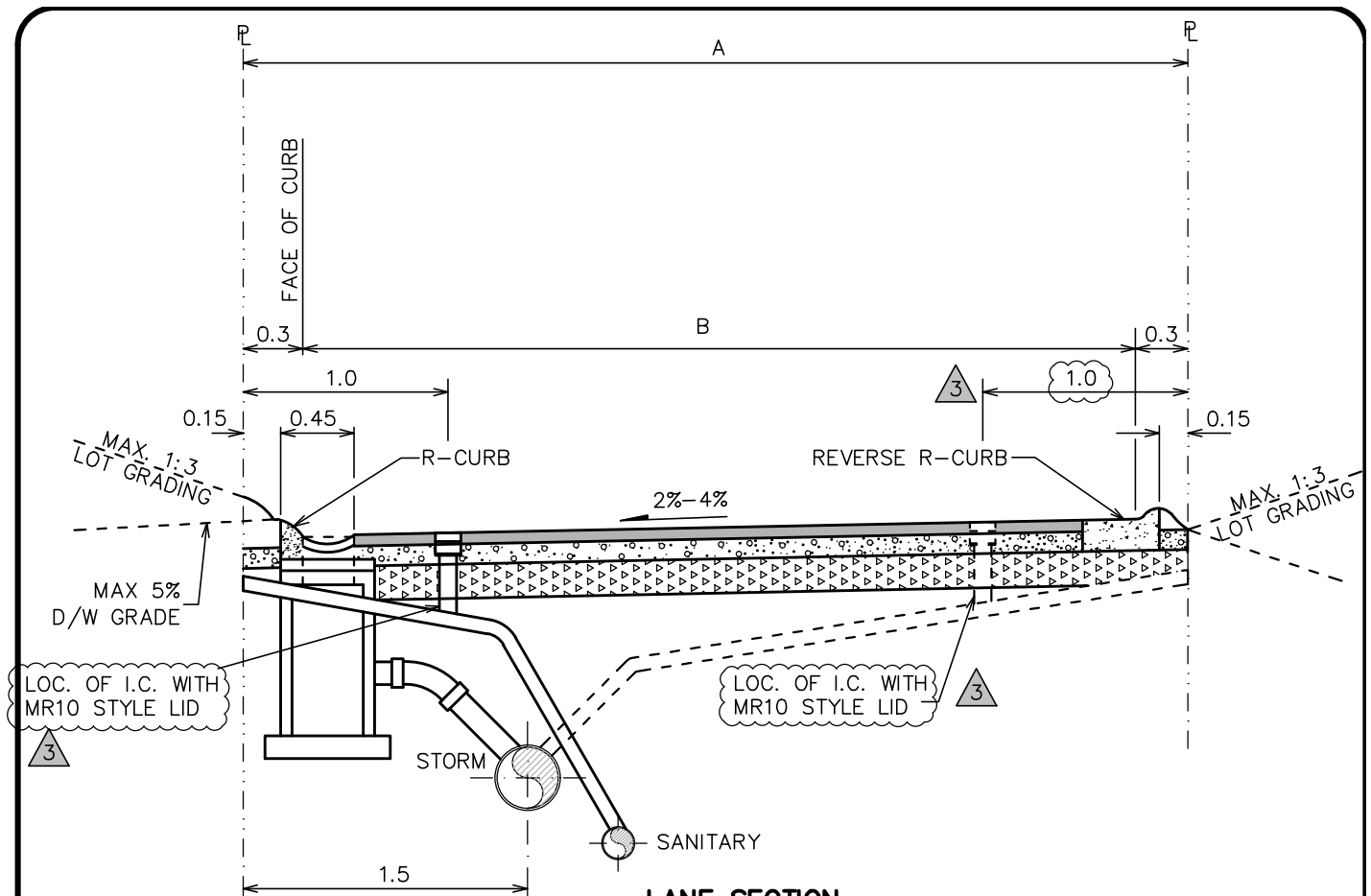

LANE SECTION

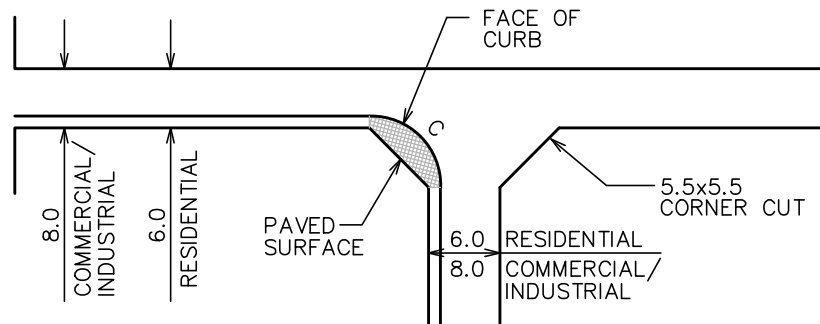

LANE INTERSECTION

	ROAD ALLOWANCE	ROADWAY	CURB RETURN RADIUS
	A	B	C
RESIDENTIAL	6.0	5.4	5.0
COLLECTOR IND/COMM	8.0	7.4	5.0

NOTES:

1. FOR DRIVEWAYS A LANDING AREA OF 6.0m LENGTH WITH MAXIMUM 5% GRADE IS REQUIRED.

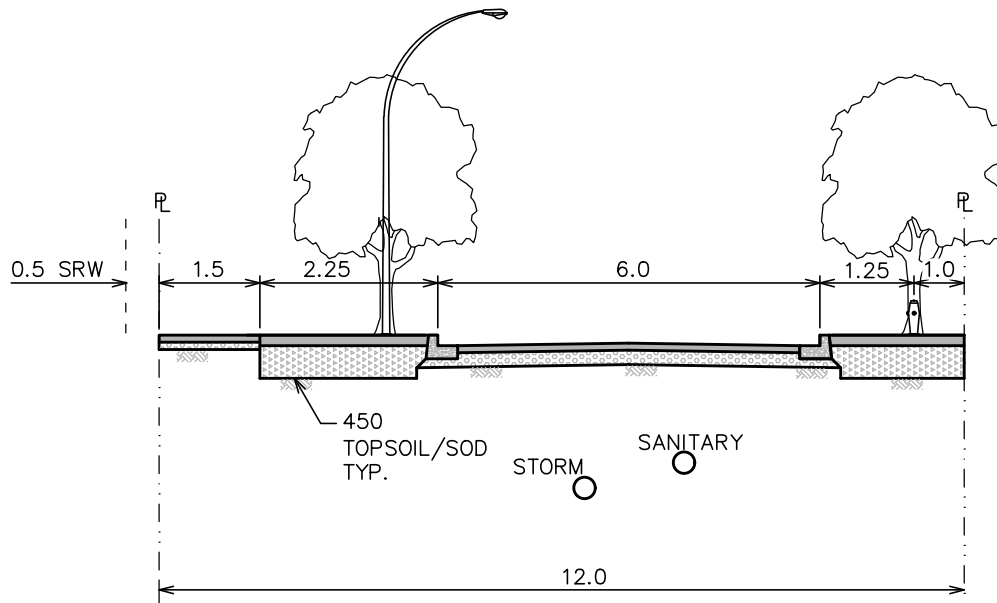

3	APRIL 2020	SCOTT NEUMAN	All Dimensions Shown In Metres, Unless Otherwise Noted
2	JULY 2016	JAIME BOAN	
1	JANUARY 2016	JAIME BOAN	
	Revision Date	Approved	Title
			LANE SECTION, STANDARD
		SUPPLEMENTARY STANDARD DRAWINGS	Approved By :
		APRIL 2020	G.M. Engineering
			DRAWING NUMBER SSD-R.12

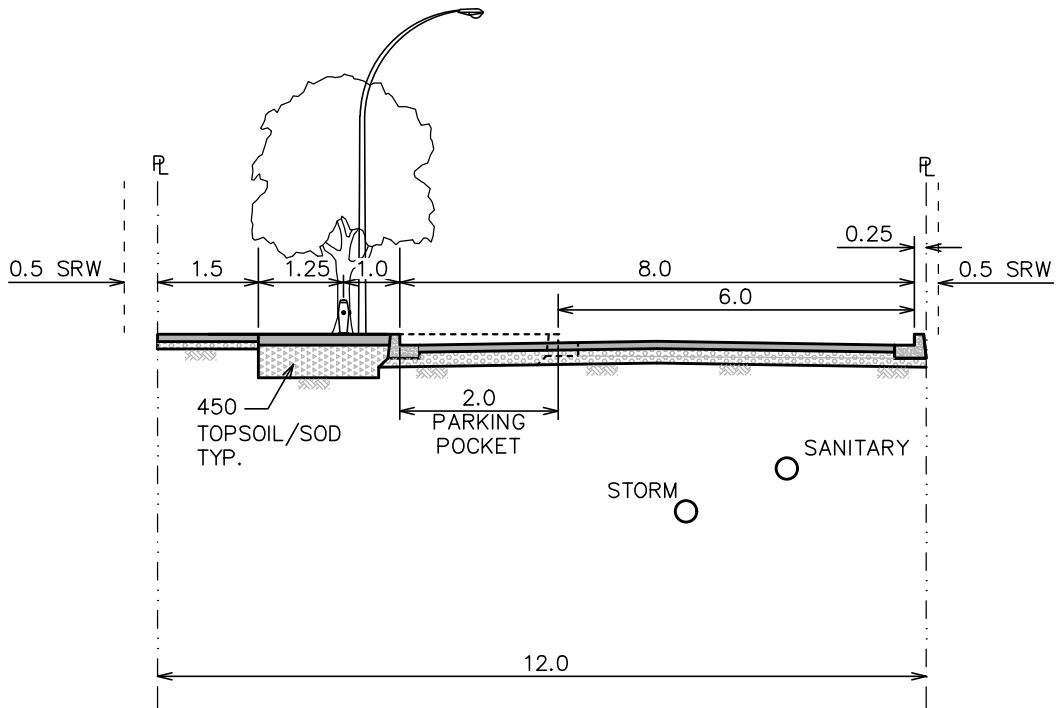

GREEN



URBAN

3	APRIL 2020	SCOTT NEUMAN	All Dimensions Shown In Metres, Unless Otherwise Noted
2	JANUARY 2016	JAIME BOAN	
1	JANUARY 2004	KOK KUEN LI	
	Revision Date	Approved	Title LANE, GREEN & URBAN
 <p>CITY OF SURREY the future lives here.</p>			Approved By :  APRIL 2020 G.M. Engineering
SUPPLEMENTARY STANDARD DRAWINGS			DRAWING NUMBER SSD-R.12.1

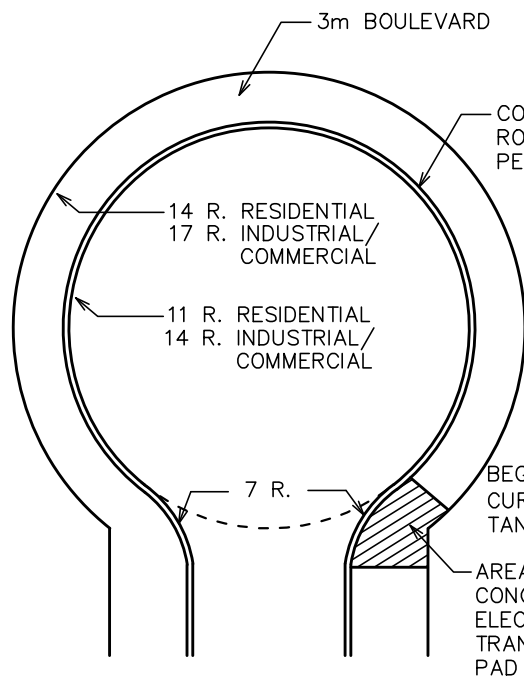

NO SIDEWALK

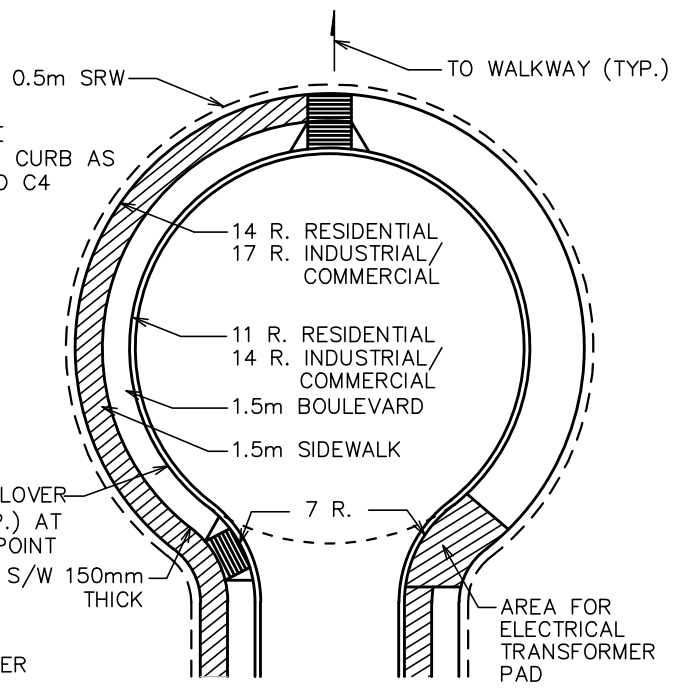

WITH SIDEWALK

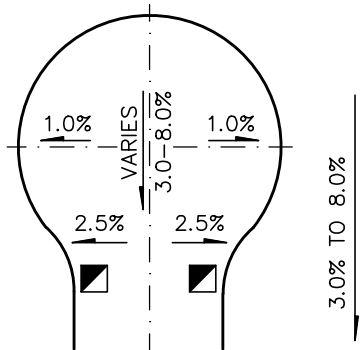
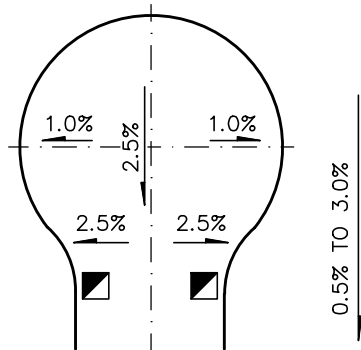

UPHILL GRADING DETAILS (TYPICAL)

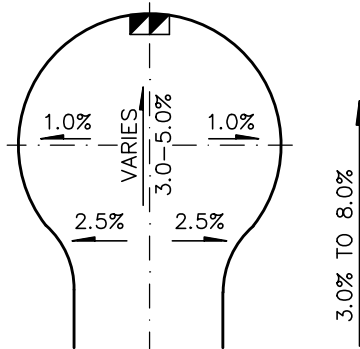
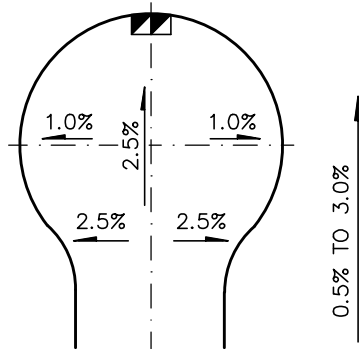

DOWNHILL GRADING DETAILS (TYPICAL)

3	APRIL 2020	SCOTT NEUMAN
2	JANUARY 2016	JAIME BOAN
1	NOVEMBER 1999	
	Revision Date	Approved

All Dimensions Shown In Metres, Unless Otherwise Noted

Title **TURNAROUND, CUL-DE-SAC BULB**



SUPPLEMENTARY STANDARD DRAWINGS



Approved By : *[Signature]*
APRIL 2020 G.M. Engineering

DRAWING NUMBER **SSD-R.13**

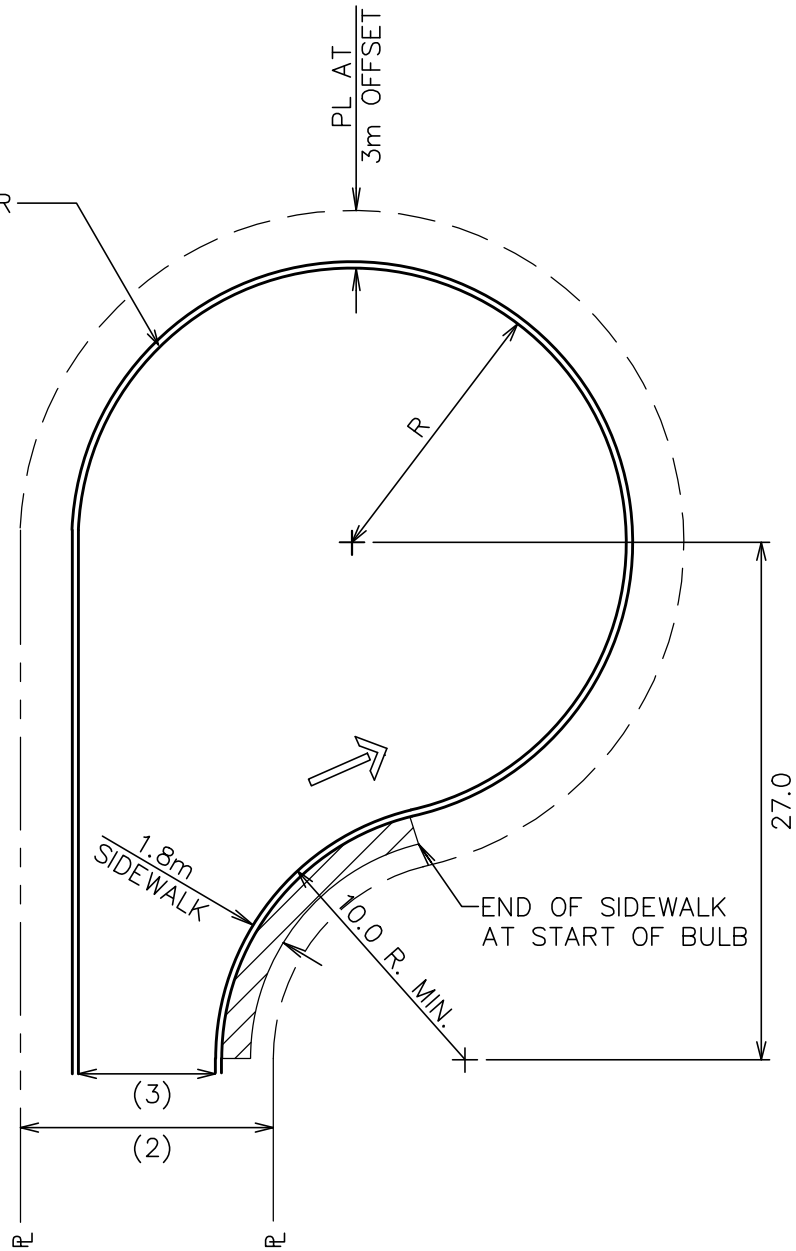
CONCRETE ROLLOVER CURB AS PER MMCD C4 (TYP.)



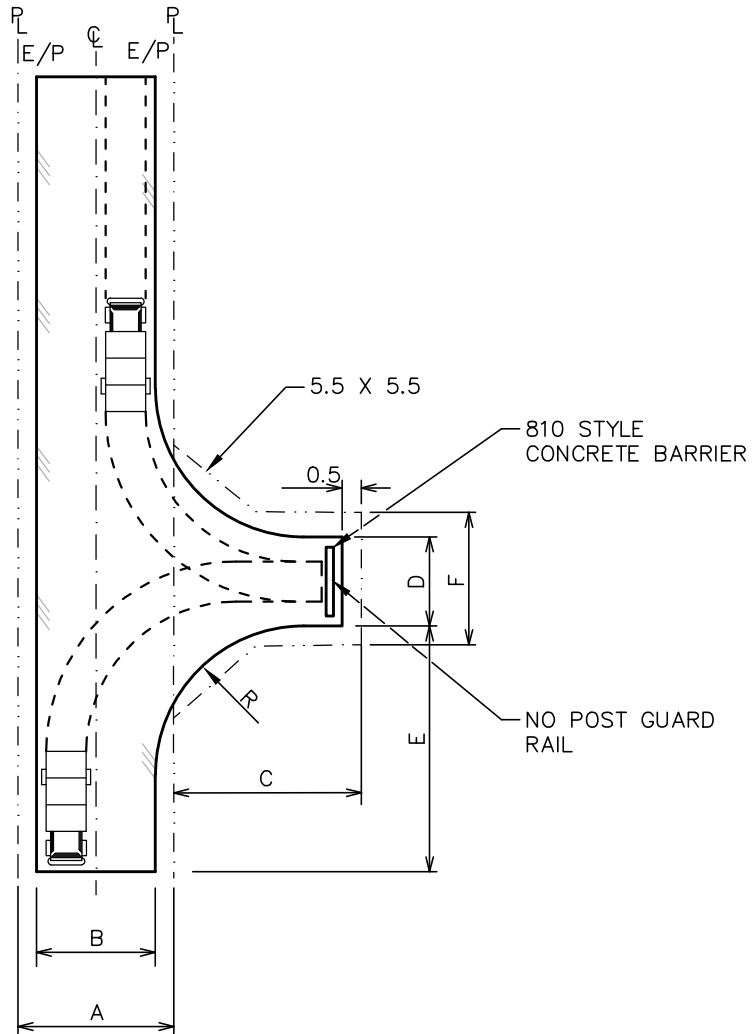

- (1) R = 14m FOR COMMERCIAL/INDUSTRIAL ZONED.
R = 11m FOR RESIDENTIAL ZONED.
- (2) ROAD DEDICATION AS PER ROADWAY CLASSIFICATION.
- (3) PAVEMENT WIDTH AS PER ROADWAY CLASSIFICATION.

3			All Dimensions Shown In Metres, Unless Otherwise Noted	
2	APRIL 2020	SCOTT NEUMAN		
1	JANUARY 2016	JAIME BOAN	Title	CUL-DE-SAC, OFFSET
	Revision Date	Approved		
 <p>CITY OF SURREY the future lives here.</p>			SUPPLEMENTARY STANDARD DRAWINGS	Approved By :  APRIL 2020 G.M. Engineering
			DRAWING NUMBER	SSD-R.13.1



DESIGN VEHICLE	LANE ALLOWANCE	PAVEMENT	DEPTH	WIDTH	LENGTH	RADIUS	ROW WIDTH
	A ⁽²⁾	B ⁽²⁾	C	D	E	R	F
SU-9	6.0	5.4	15.0	5.0	17.0	5.0	6.0
P	6.0	5.4	7.0	3.5	10.0	5.0	4.5

NOTES: (1) DESIGN VEHICLE AS DIRECTED BY THE CITY ENGINEER.
(2) 8.0m ROAD ROW, 7.4m PAVEMENT FOR COMMERCIAL/INDUSTRIAL ZONES.

3			All Dimensions Shown In Metres, Unless Otherwise Noted	
2	APRIL 2020	SCOTT NEUMAN		
1	JANUARY 2016	JAIME BOAN	Title	TURNAROUND HAMMERHEAD
	Revision Date	Approved		
		SUPPLEMENTARY STANDARD DRAWINGS	Approved By : 	DRAWING NUMBER SSD-R.14
			APRIL 2020	G.M. Engineering

LEFT TURN BAY DETAIL

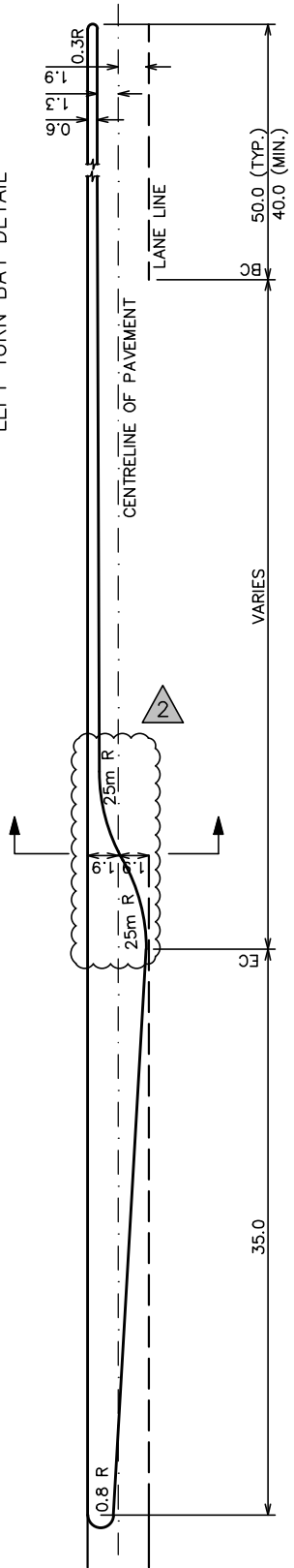

RAISED MEDIAN DEVELOPED FROM TWO-WAY LEFT LANE

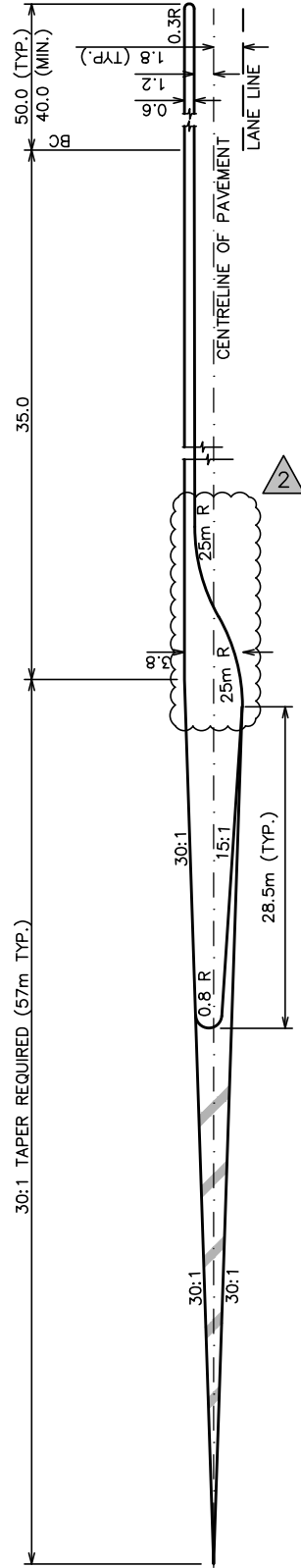

RAISED MEDIAN DEVELOPED FROM CENTRELINE

NOTE: (1) REFER TO SSD-R.15.2 FOR NARROW (SKINNY) MEDIAN DESIGN.
 (2) SLEEVES TO BE INSTALLED FOR MEDIAN SIGNS.

3		
2	APRIL 2020	SCOTT NEUMAN
1	JANUARY 2016	JAIME BOAN
	Revision Date	Approved

All Dimensions Shown In Metres, Unless Otherwise Noted	
Title	RAISED MEDIAN, LEFT TURN BAY

 **CITY OF SURREY**
the future lives here.

SUPPLEMENTARY STANDARD DRAWINGS

Approved By : 

APRIL 2020 G.M. Engineering

DRAWING NUMBER
SSD-R.15

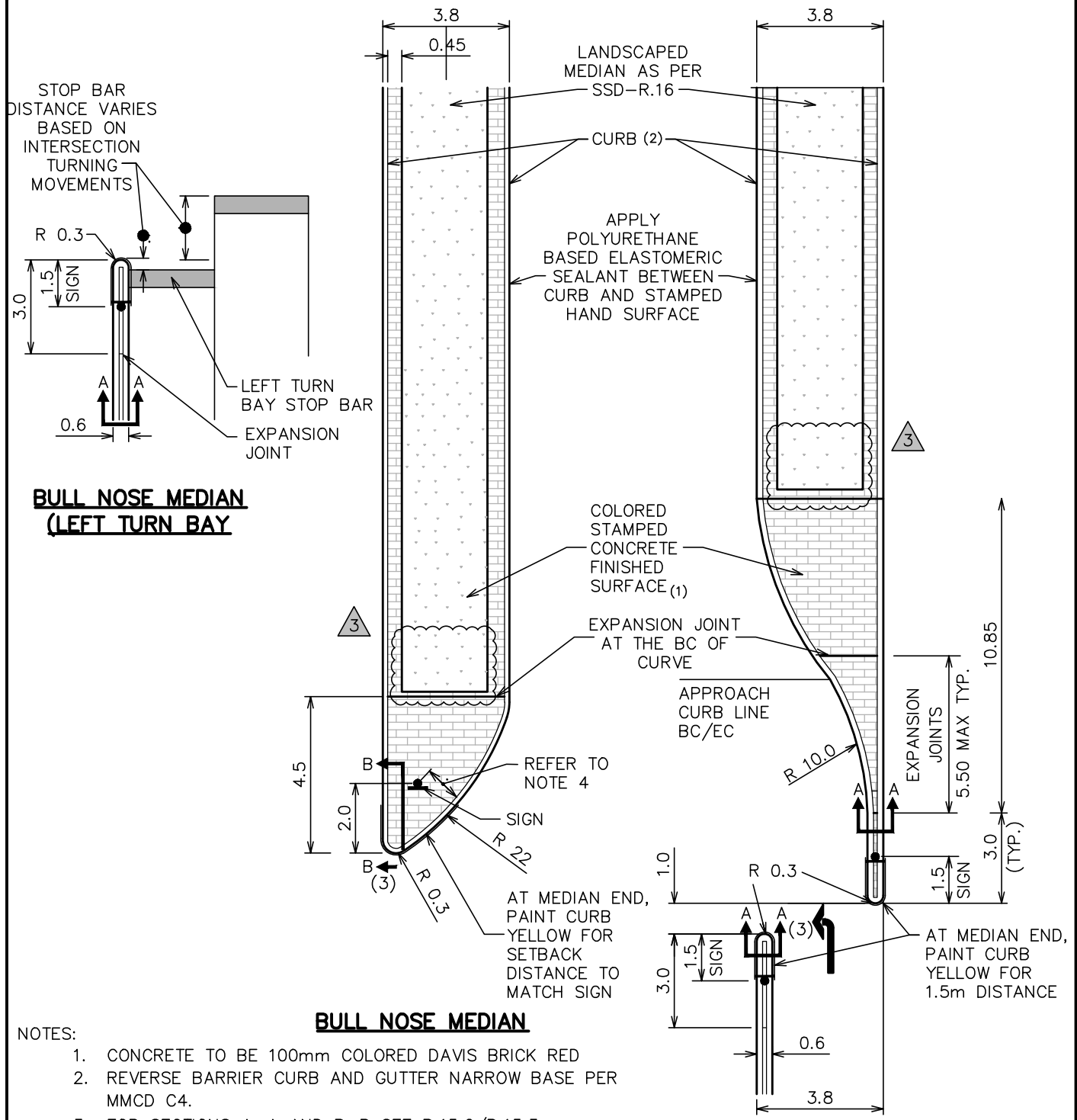

- NOTES:
1. CONCRETE TO BE 100mm COLORED DAVIS BRICK RED
 2. REVERSE BARRIER CURB AND GUTTER NARROW BASE PER MMCD C4.
 3. FOR SECTIONS A-A AND B-B SEE R.15.2/R.15.3
 4. SIGN POST TO BE 0.8m OFFSET FROM APPROACH FACING CURB.
 5. NOT REQUIRED FOR TRAILING END OF MEDIAN AS VEHICLE ENTERS A LEFT TURN BAY.

3	APRIL 2020	SCOTT NEUMAN	All Dimensions Shown In Metres, Unless Otherwise Noted
	2	JULY 2016	
1	JANUARY 2016	JAIME BOAN	Title
	Revision Date	Approved	RAISED MEDIAN, END TREATMENT
		SUPPLEMENTARY STANDARD DRAWINGS	Approved By :
		APRIL 2020	G.M. Engineering
			DRAWING NUMBER SSD-R.15.1

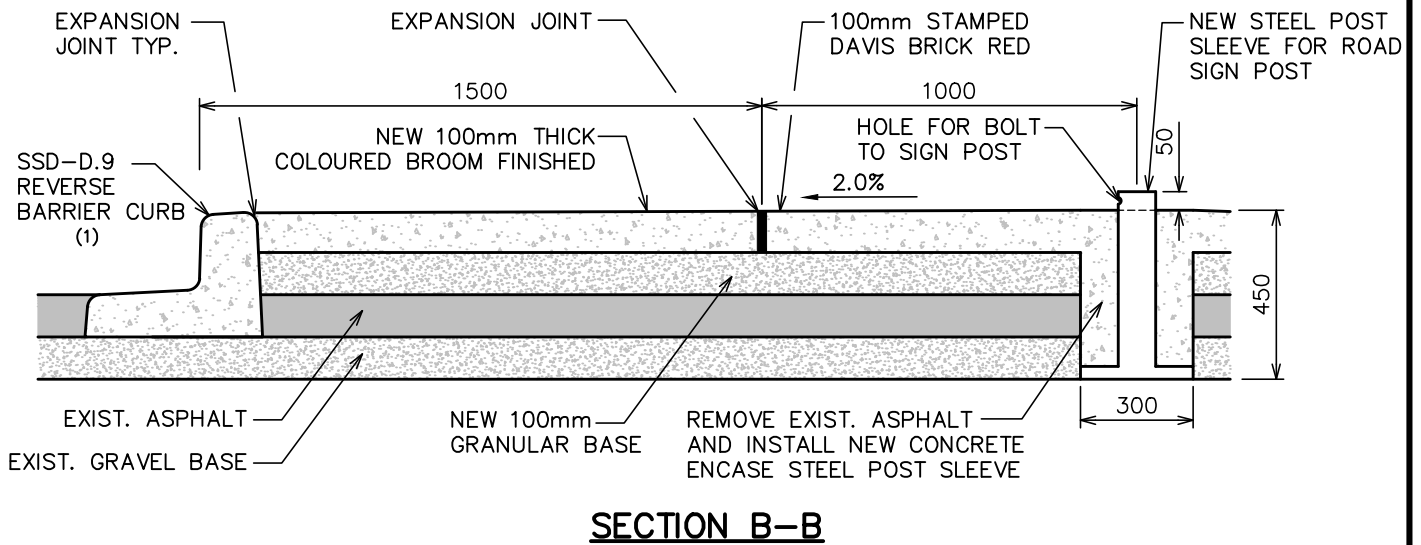
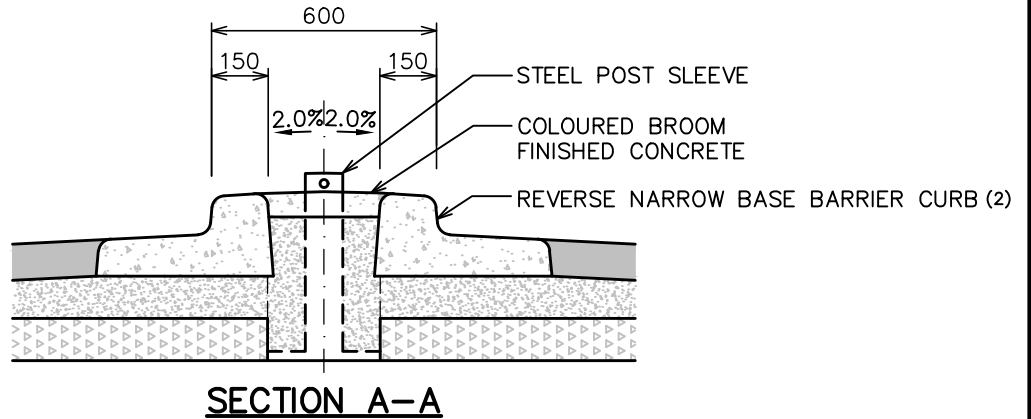

- NOTES: (1) CURB AND GUTTER TO BE BIKE FRIENDLY BARRIER CURB AS PER SSD-D.9, UNLESS APPROVED OTHERWISE
 (2) BULL NOSE END TO BE NARROW BASE BARRIER CURB AS PER MMCD DWG C4

3			All Dimensions Shown In Millimetres, Unless Otherwise Noted
2	APRIL 2020	SCOTT NEUMAN	
1	JANUARY 2016	JAIME BOAN	
	Revision Date	Approved	Title RAISED MEDIAN, BULL NOSE END DETAIL BARRIER CURB
CITY OF SURREY <small>the future lives here.</small>			Approved By :
			 APRIL 2020 G.M. Engineering
			DRAWING NUMBER SSD-R.15.2

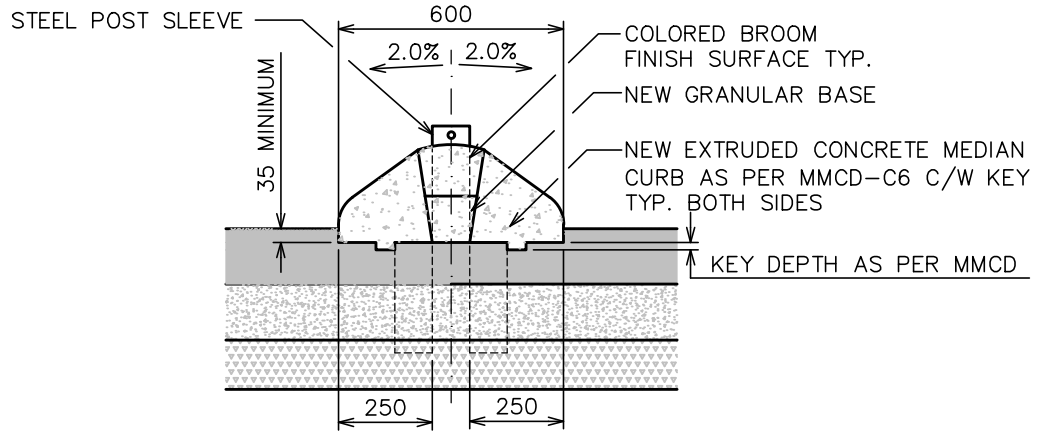

**SECTION A-A
MEDIAN AT LEFT TURN BAY
TYP. SECTION**

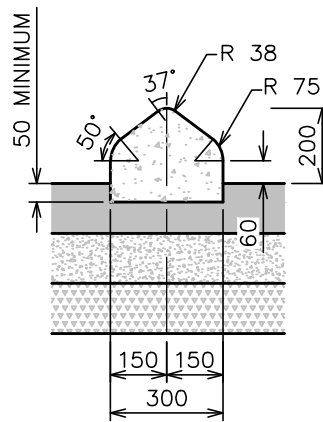

**EXTRUDED CONCRETE CURB CENTER
DIVIDER NARROW SECTION DETAIL**

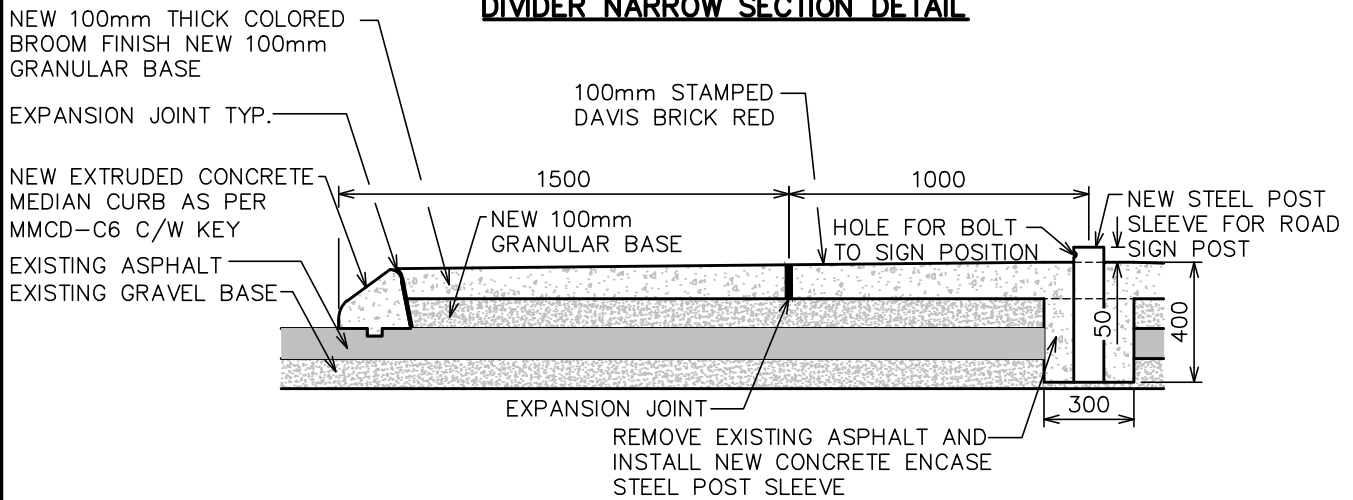

SECTION B-B

3		
2	APRIL 2020	SCOTT NEUMAN
1	JANUARY 2016	JAIME BOAN
	Revision Date	Approved

All Dimensions Shown In Millimetres,
Unless Otherwise Noted

Title **RAISED MEDIAN,
BULL NOSE MEDIAN CURB END DETAIL**

SUPPLEMENTARY
STANDARD
DRAWINGS

Approved By : *[Signature]*
APRIL 2020 G.M. Engineering

DRAWING NUMBER
SSD-R.15.3

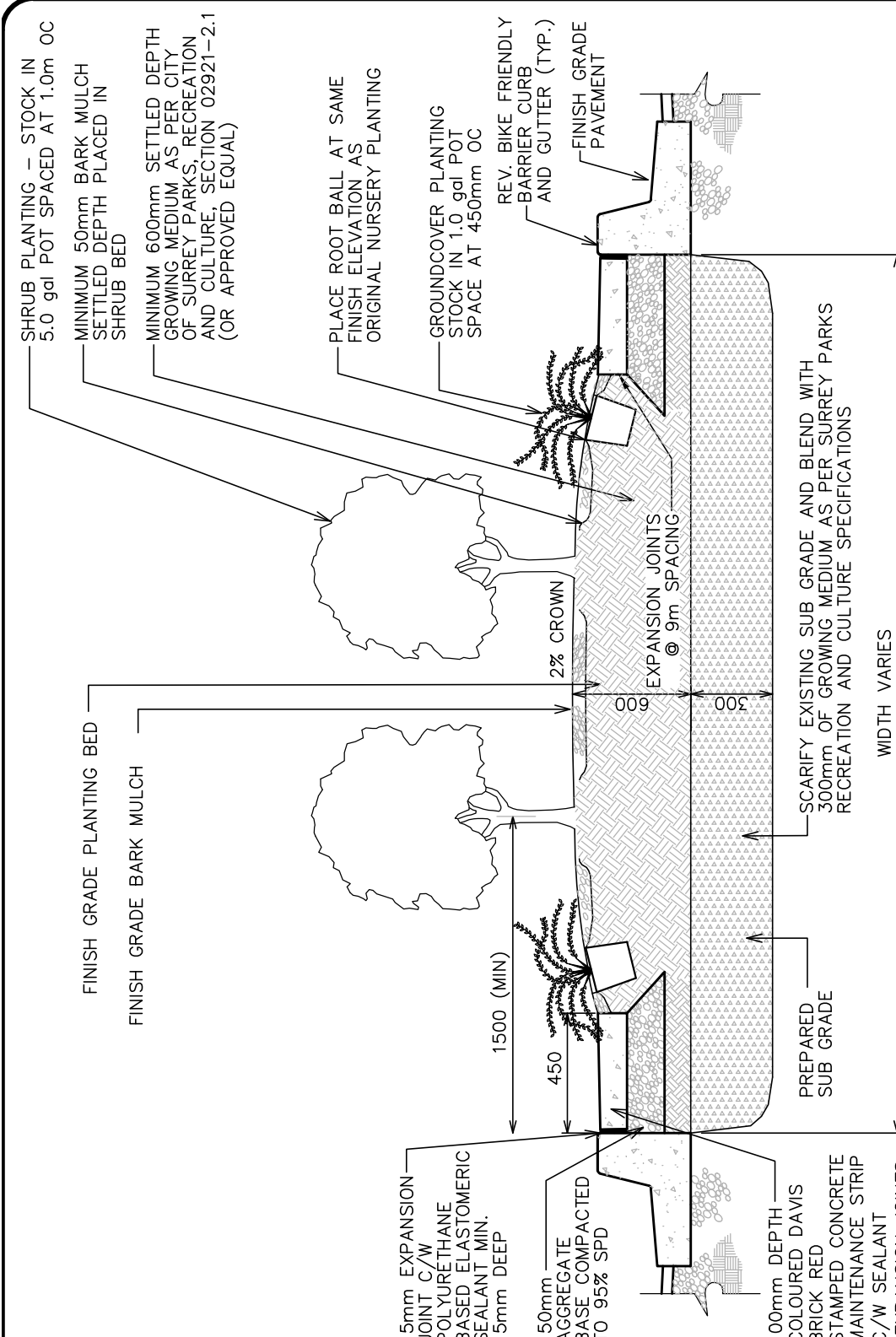

- NOTES:
- 1) CONCRETE MAINTENANCE STRIP, SOIL DEPTH, AND SOIL QUALITY APPLY TO ALL LANDSCAPE MEDIANS INCLUDING GRASS MEDIANS.
 - 2) PLANT MATERIAL TO BE SELECTED FROM LIST OF ACCEPTABLE PLANT MATERIAL CITY OF SURREY PARKS DIVISION STANDARD CONSTRUCTION DOCUMENTS.
 - 3) PROTECT PLANT MATERIAL FROM DAMAGE DURING TRANSPORTATION AND PLANTING.
 - 4) LOCATE AND FLAG ALL BURIED UTILITIES IN PLANTING BEDS PRIOR TO DIGGING. ENSURE THAT UTILITIES ARE PROTECTED DURING CONSTRUCTION.
 - 5) DO NOT EXPOSE PLANTS TO DIRECT SUN OR FROST.
 - 6) PRUNE ONLY IN ACCORDANCE WITH STANDARD CONSTRUCTION DOCUMENTS.

3		
2	APRIL 2020	SCOTT NEUMAN
1	JANUARY 2016	JAIME BOAN
	Revision Date	Approved

All Dimensions Shown In Metres, Unless Otherwise Noted

Title **MEDIAN PLANTING SECTION**

SUPPLEMENTARY STANDARD DRAWINGS

Approved By :

APRIL 2020 G.M. Engineering

DRAWING NUMBER **SSD-R.16**

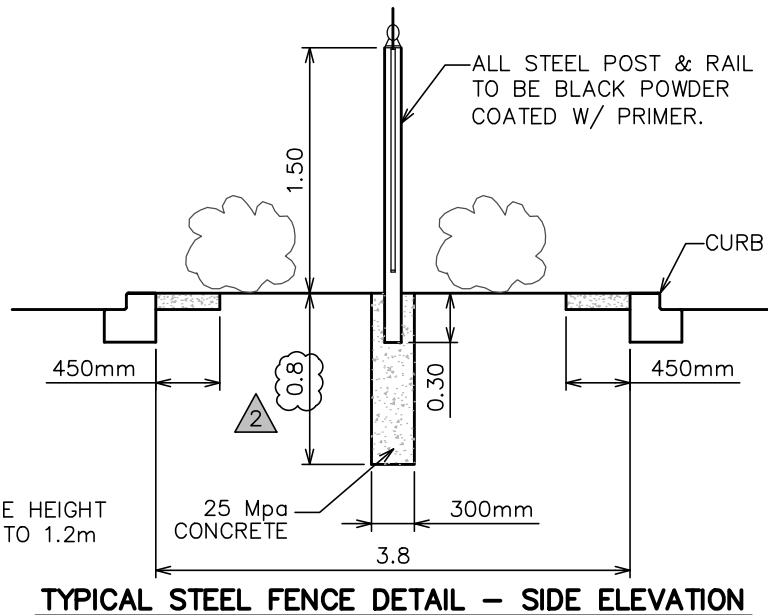
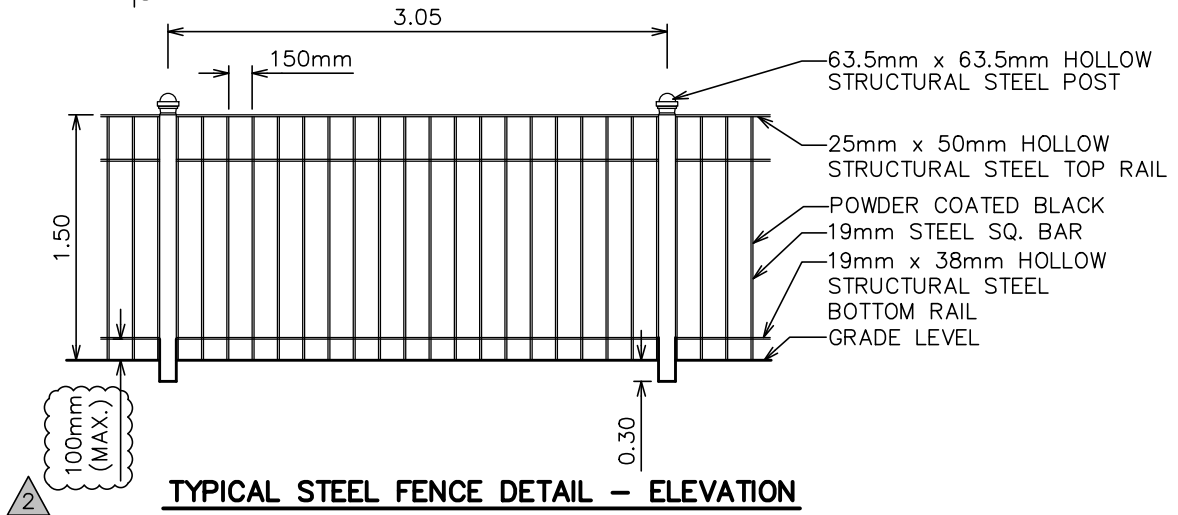
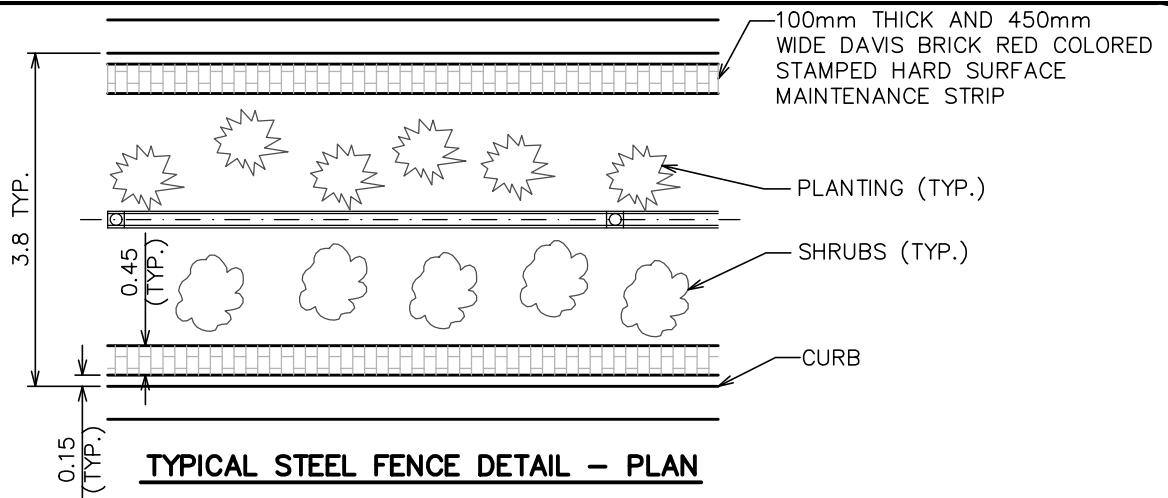

NOTE:

AT INTERSECTION APPROACHES, FENCE HEIGHT CAN BE ADJUSTED TO 1.2m

3			All Dimensions Shown In Metres, Unless Otherwise Noted
2	APRIL 2020	VICTOR JHINGAN	
1	JANUARY 2016	JAIME BOAN	
	Revision Date	Approved	Title RAISED MEDIAN, FENCE
 <p>CITY OF SURREY the future lives here.</p>			Approved By :  APRIL 2020 G.M. Engineering
SUPPLEMENTARY STANDARD DRAWINGS			DRAWING NUMBER SSD-R.17

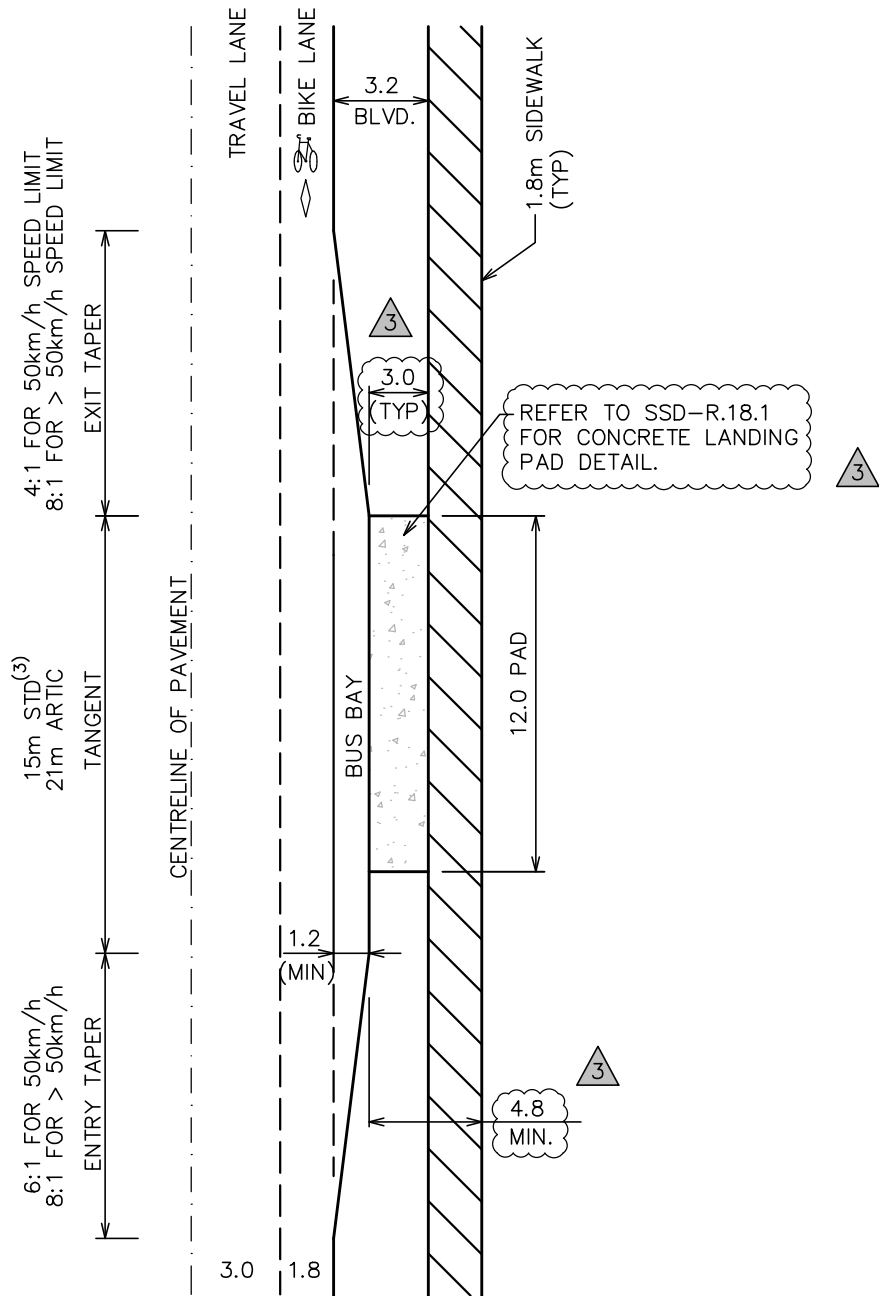

NOTES:

1. BUS BAY REQUIRED ON ALL ROADS WITH VOLUME $\geq 12,000$ AADT.
2. COAST MOUNTAIN BUS COMPANY TO SPECIFY LOCATION AND TYPE OF ENTRY TREATMENT.
3. ADD 8m BETWEEN TANGENTS IF TWO STOPS WITH INDEPENDANT DEPARTURE ARE REQUIRED.
4. ADDITIONAL LAND DEDICATION MAY BE REQUIRED.

3	APRIL 2020	SCOTT NEUMAN	All Dimensions Shown In Metres, Unless Otherwise Noted
2	JANUARY 2016	JAIME BOAN	
1	JANUARY 2004	KOK KUEN LI	Title BUS STOP, BAY DETAILS
	Revision Date	Approved	
			Approved By :
SUPPLEMENTARY STANDARD DRAWINGS		APRIL 2020	G.M. Engineering
			DRAWING NUMBER SSD-R.18

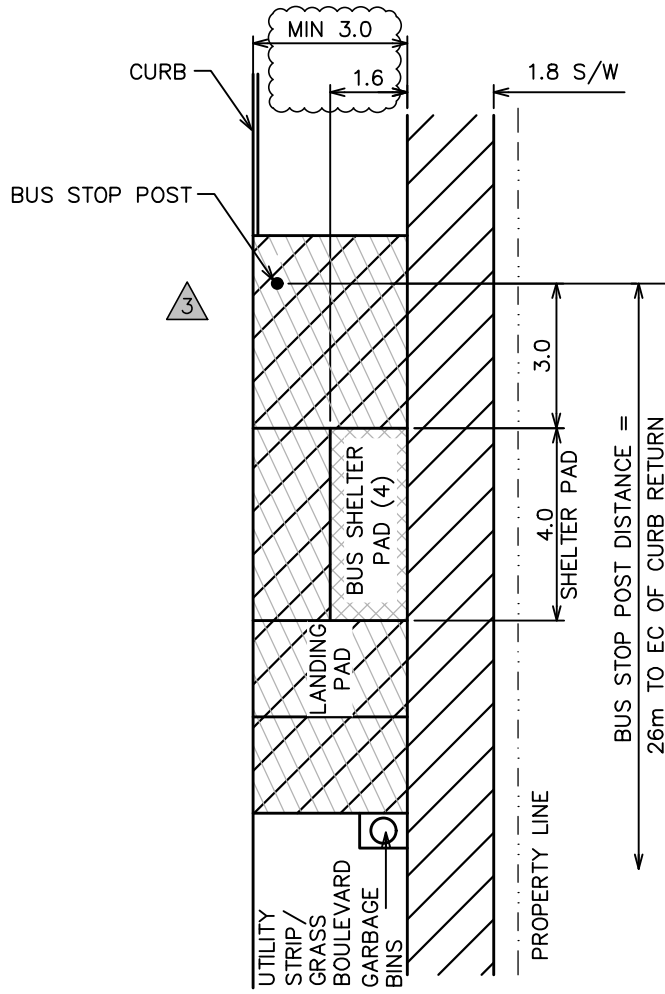

**BUS SHELTER LOCATION
SIDEWALK BEHIND SHELTER**

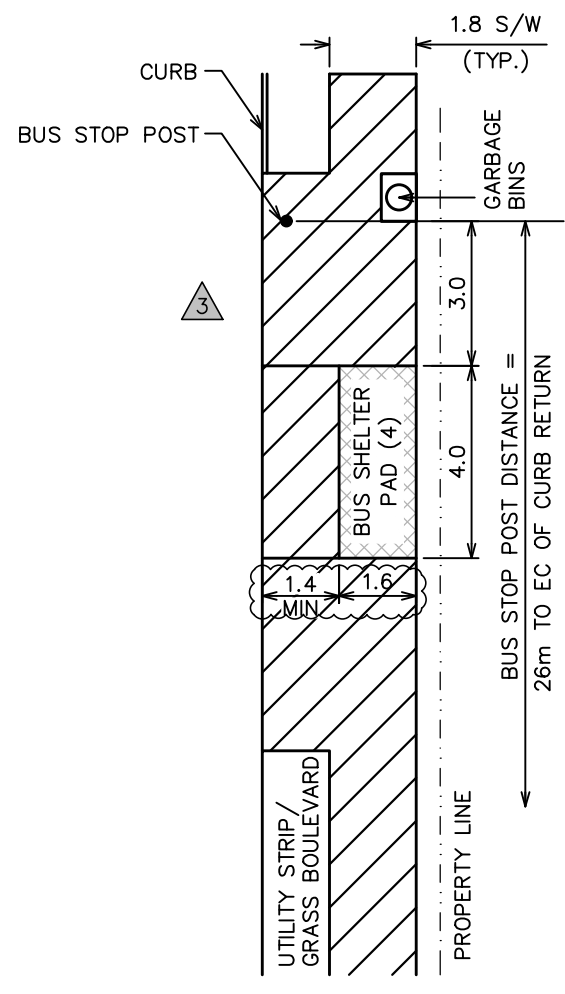

**BUS SHELTER LOCATION
SIDEWALK IN LINE WITH SHELTER**

NOTES:

1. STANDARD SHELTER TO BE CONSTRUCTED IN FRONT OF SIDEWALK (5.0 MIN BOULEVARD) IF NOT ENOUGH WIDTH, CITY MUST REVIEW AND APPROVE DESIGN BEHIND SIDEWALK.
2. REFER TO SSD-R.18.2 FOR SHELTER PAD DETAIL.

3	APRIL 2020	SCOTT NEUMAN
2	JULY 2016	JAIME BOAN
1	JANUARY 2016	JAIME BOAN
	Revision Date	Approved

All Dimensions Shown In Millimetres,
Unless Otherwise Noted

Title **BUS STOP,
LANDING PAD**





SUPPLEMENTARY
STANDARD
DRAWINGS

Approved By : *[Signature]*
APRIL 2020 G.M. Engineering

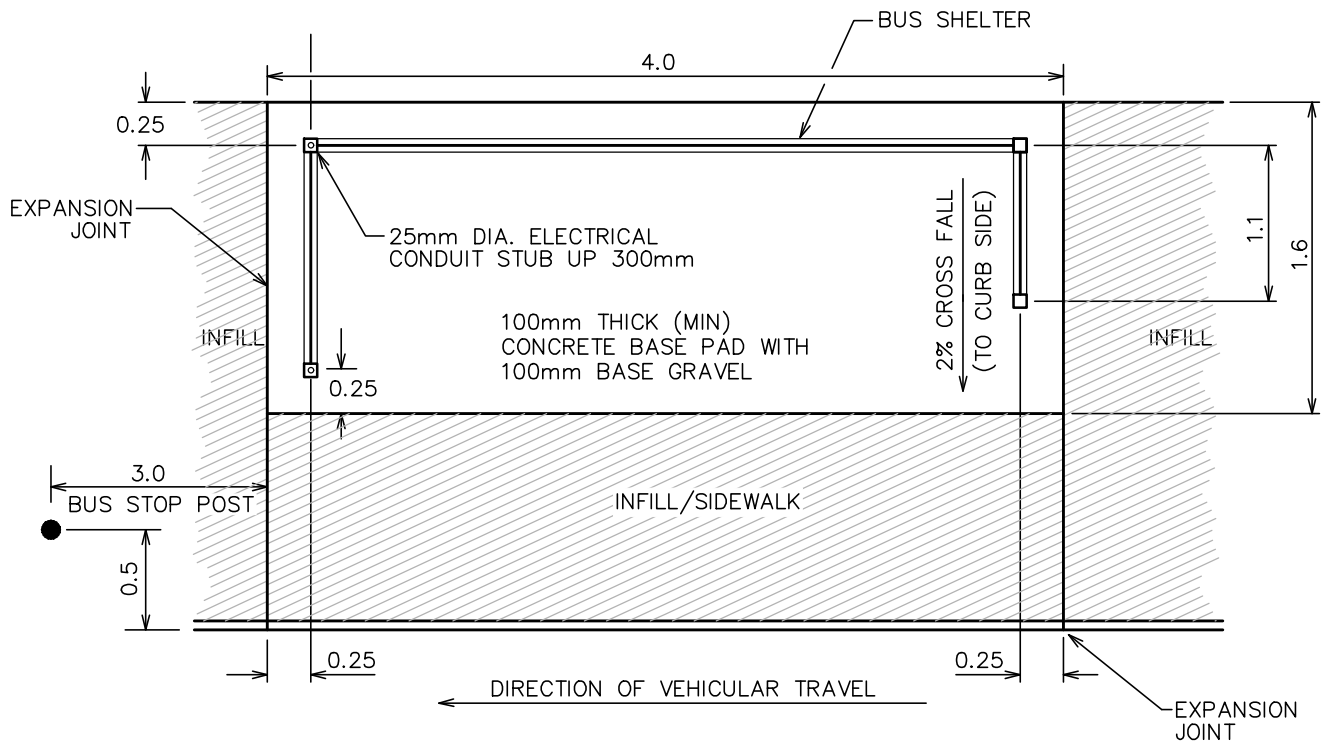
DRAWING NUMBER
SSD-R.18.1



BUS SHELTER PAD DETAIL

3			All Dimensions Shown In Metres, Unless Otherwise Noted
2	APRIL 2020	SCOTT NEUMAN	
1	JANUARY 2016	JAIME BOAN	
	Revision Date	Approved	Title BUS STOP, BUS SHELTER PAD DETAILS
 <p>CITY OF SURREY the future lives here.</p>			Approved By :  APRIL 2020 G.M. Engineering
SUPPLEMENTARY STANDARD DRAWINGS			DRAWING NUMBER SSD-R.18.2

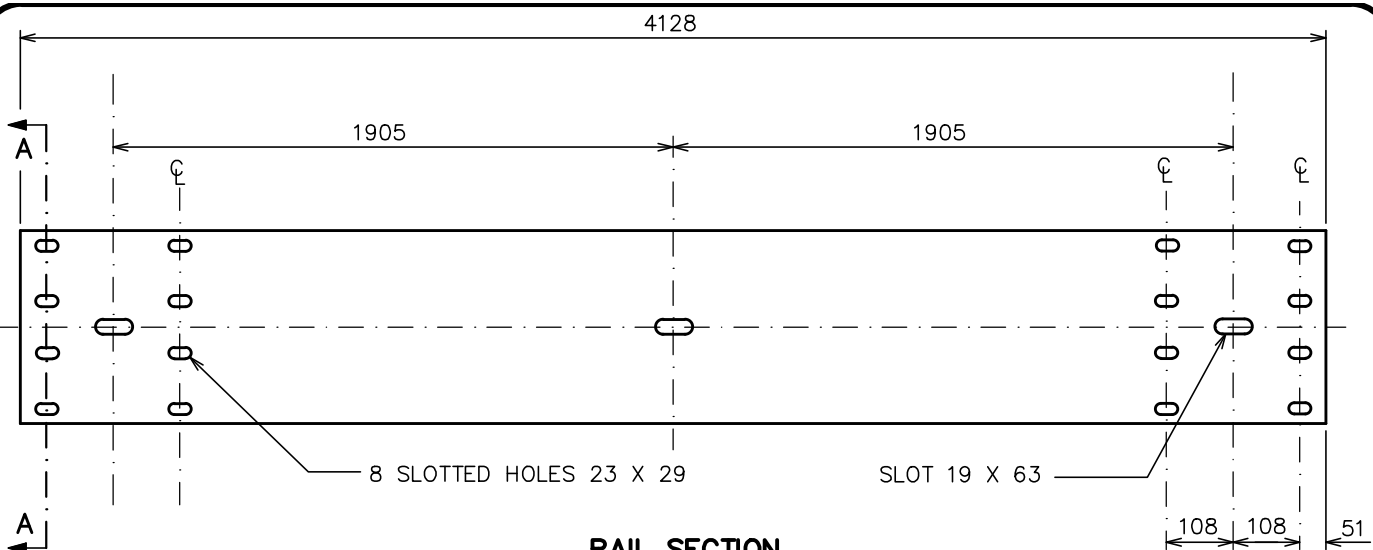

RAIL SECTION

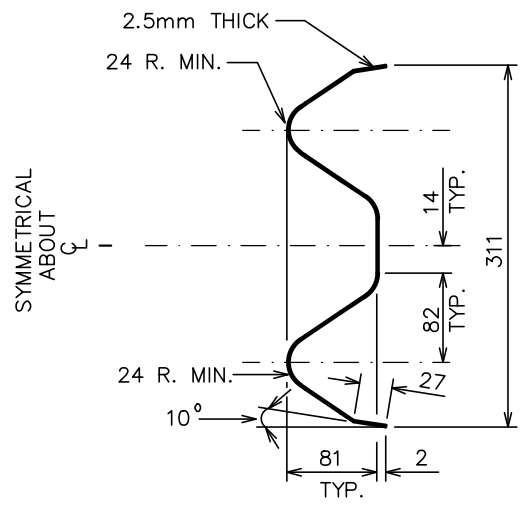

ENLARGED SECTION A-A

(SECTION B-B SIMILAR)

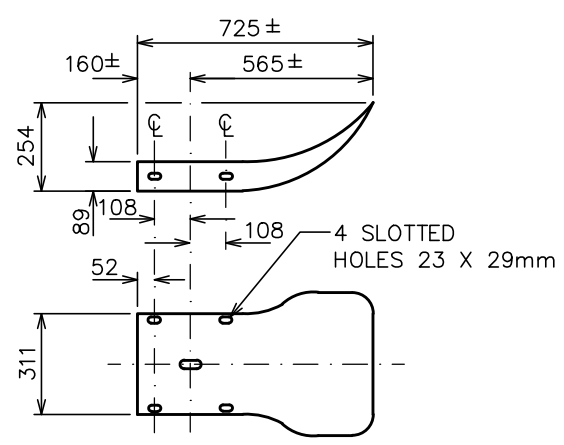

TERMINAL SECTION

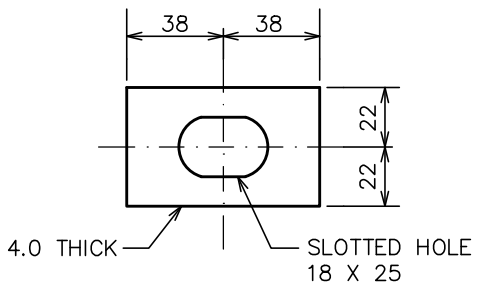

RECTANGULAR WASHER

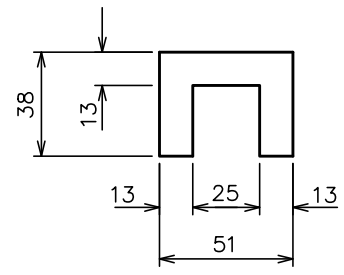

SHIM

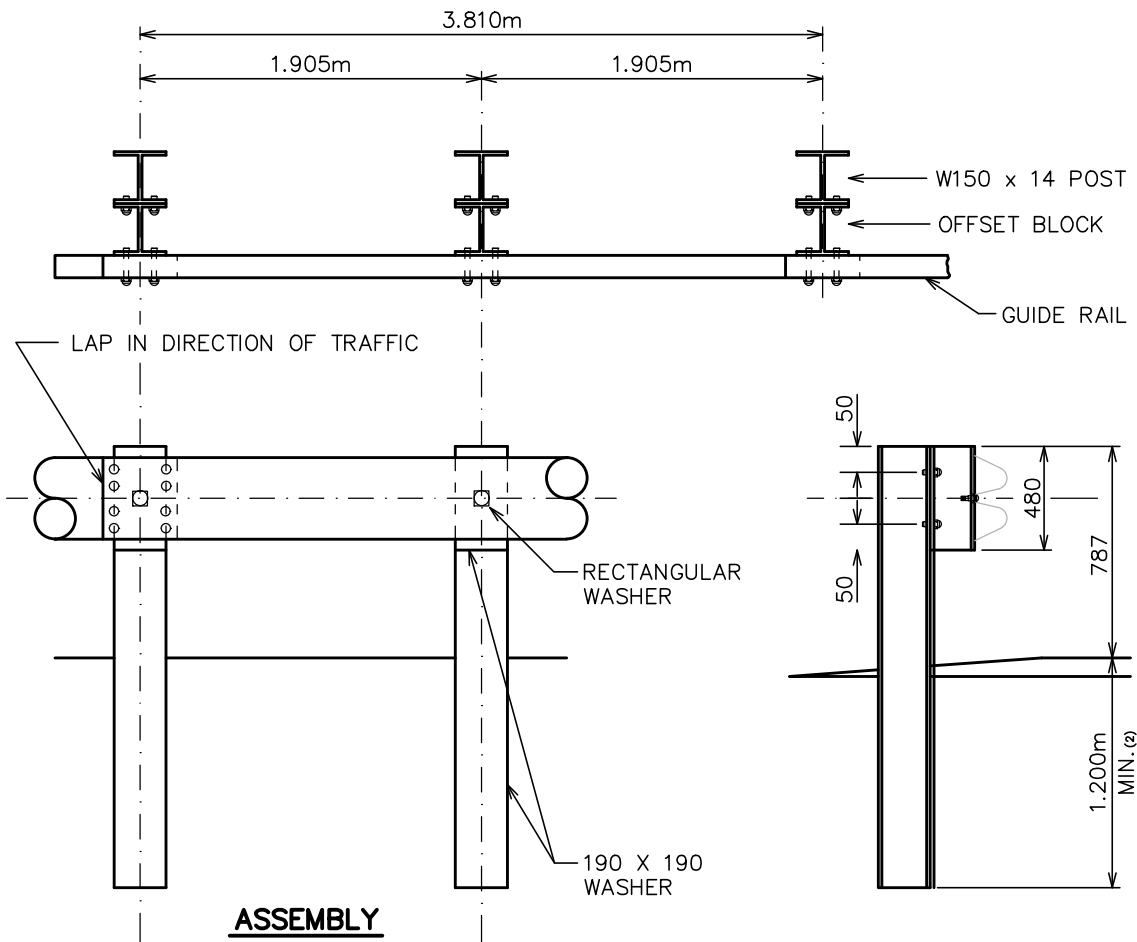
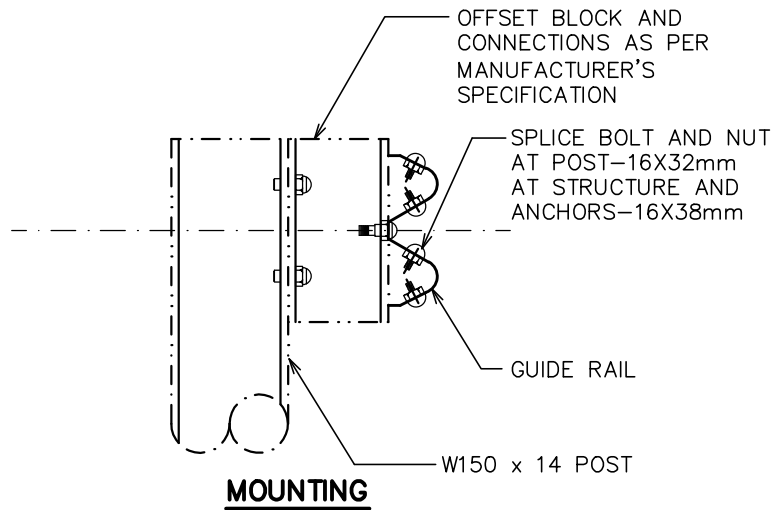

NOTE: (1) ALL METAL TO BE GALVANIZED FINISH

3		All Dimensions Shown In Millimetres, Unless Otherwise Noted
2	APRIL 2020 SCOTT NEUMAN	
1	JANUARY 2016 JAIME BOAN	
	Revision Date Approved	
SUPPLEMENTARY STANDARD DRAWINGS		Title GUARD RAIL Approved By : APRIL 2020 G.M. Engineering
		DRAWING NUMBER SSD-R.19



NOTE:

1. ALL METAL TO BE GALVANIZED FINISH.
2. DEPTH OF BURIAL TO BE DESIGNED BASED ON SOIL CONDITION.

3		All Dimensions Shown In Millimetres, Unless Otherwise Noted
2	APRIL 2020 SCOTT NEUMAN	
1	JANUARY 2016 JAIME BOAN	
	Revision Date Approved	
GUARD RAIL – ASSEMBLY & MOUNTING		Approved By : 
 SUPPLEMENTARY STANDARD DRAWINGS		
APRIL 2020 G.M. Engineering		DRAWING NUMBER SSD-R.19.1

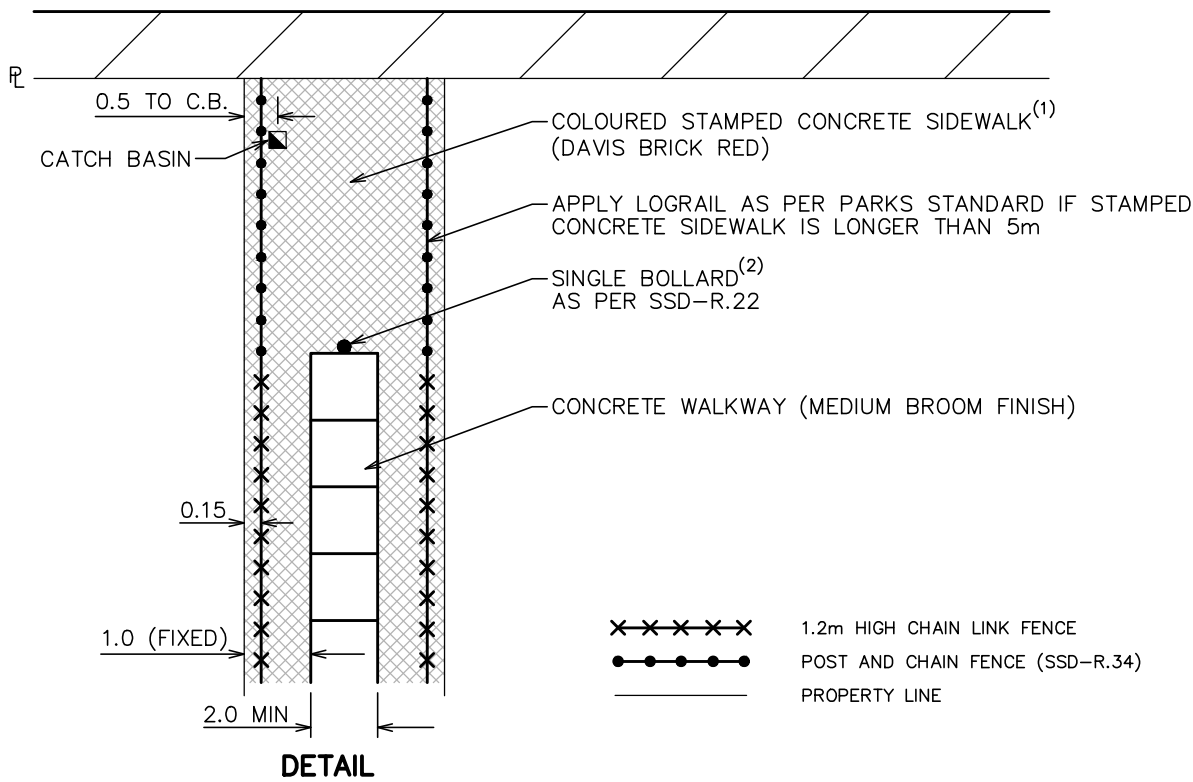
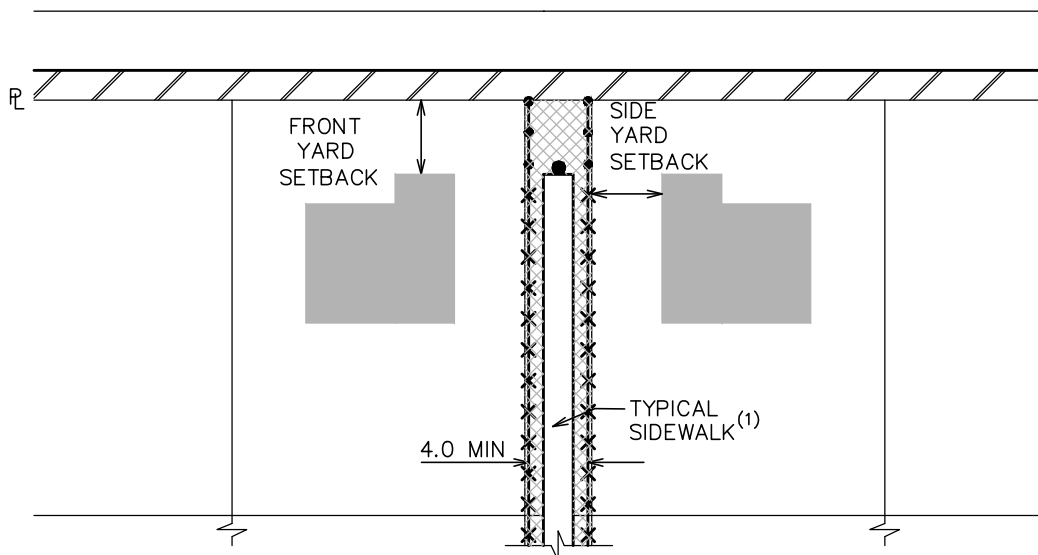

- NOTES: (1) REFER TO DESIGN CRITERIA FOR LENGTH TO WIDTH RATIO.
 (2) TWO BOLLARDS @ 2.0m SPACING REQUIRED FOR WALKWAYS WIDER THAN 4.0m.
 (3) BAFFLE GATES MAY BE USED AS SUBSTITUTE AT THE DIRECTION OF THE CITY OF SURREY

4	APRIL 2020	SCOTT NEUMAN	All Dimensions Shown In Metres, Unless Otherwise Noted
3	JANUARY 2016	JAIME BOAN	
2	MARCH 2004	KOK KUEN LI	
	Revision Date	Approved	
			Title
			WALKWAYS, ENGINEERING OR EMERGENCY ACCESS
			Approved By :
SUPPLEMENTARY STANDARD DRAWINGS			 G.M. Engineering
			DRAWING NUMBER
			SSD-R.20
			APRIL 2020

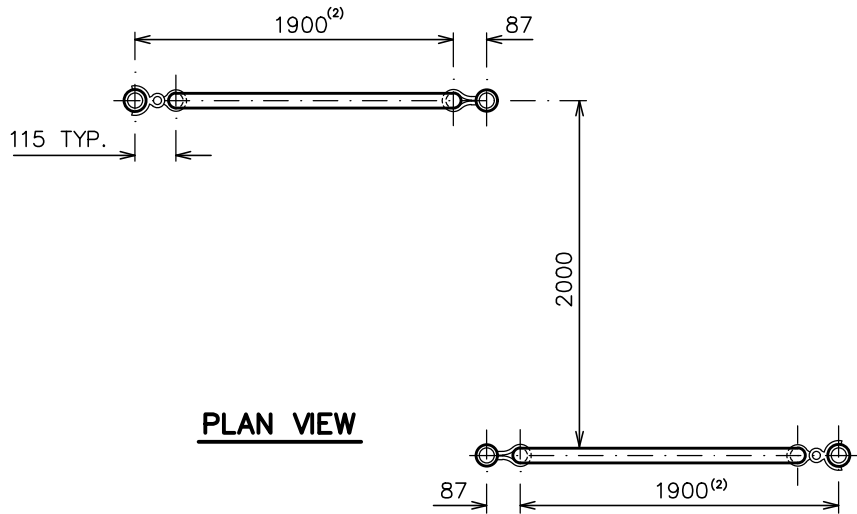

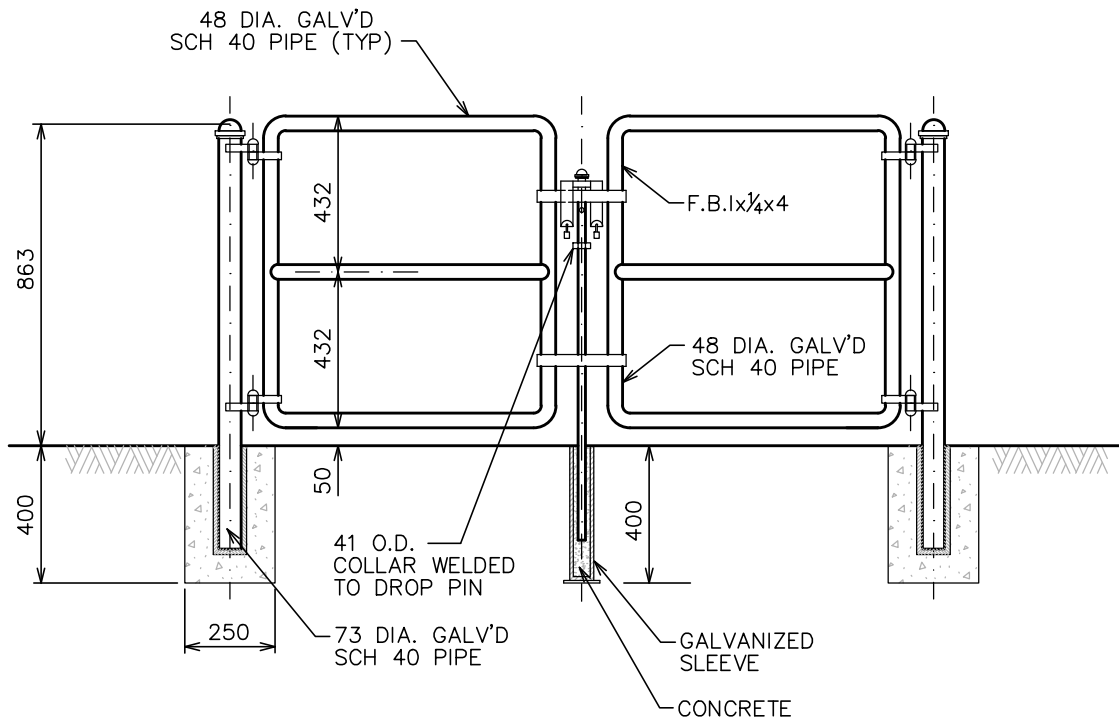

PLAN VIEW



ELEVATION VIEW

NOTE:

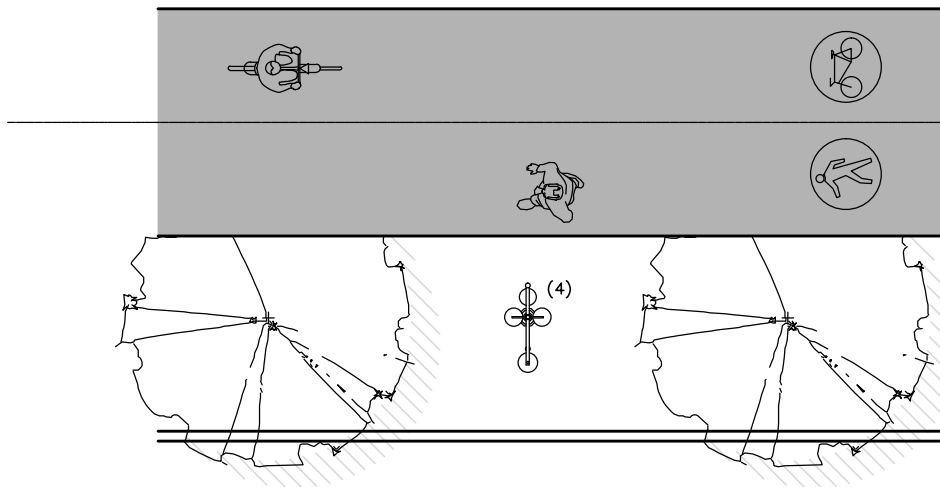
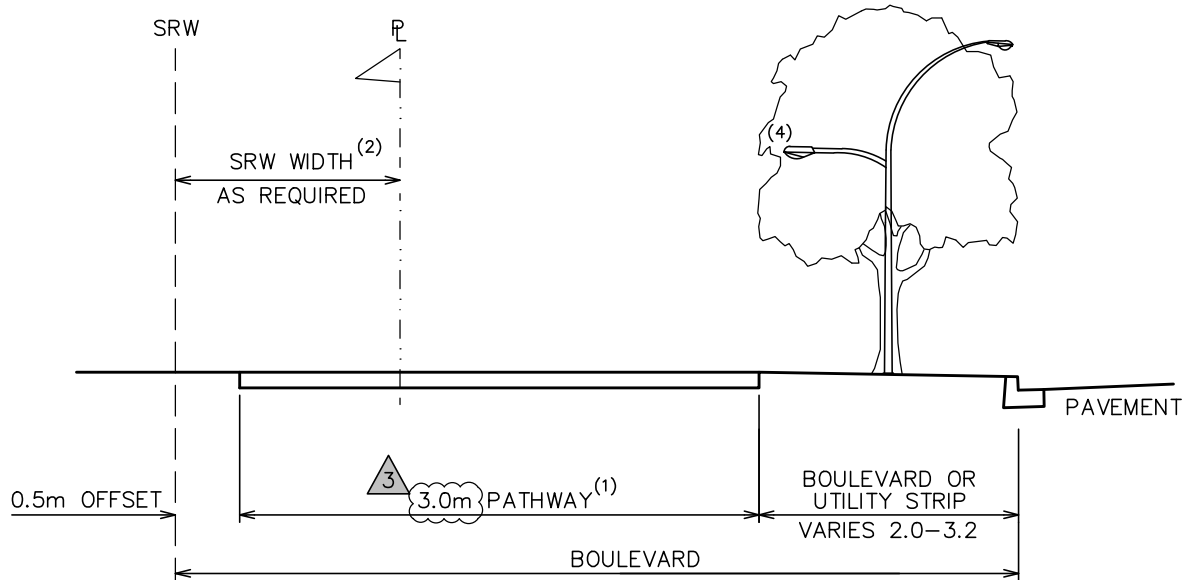

1. ALL JOINTS SEAL-WELDED AND PAINTED WITH ZINC RICH PAINT.
2. REDUCE TO 1400 FOR 3m WIDE PATHS.

3			All Dimensions Shown In Millimetres, Unless Otherwise Noted
2	APRIL 2020	SCOTT NEUMAN	Title WALKWAYS, BAFFLE GATE
1	JANUARY 2016	JAIME BOAN	
	Revision Date	Approved	
 SUPPLEMENTARY STANDARD DRAWINGS			Approved By :  APRIL 2020 G.M. Engineering
			DRAWING NUMBER SSD-R.20.1



NOTES:

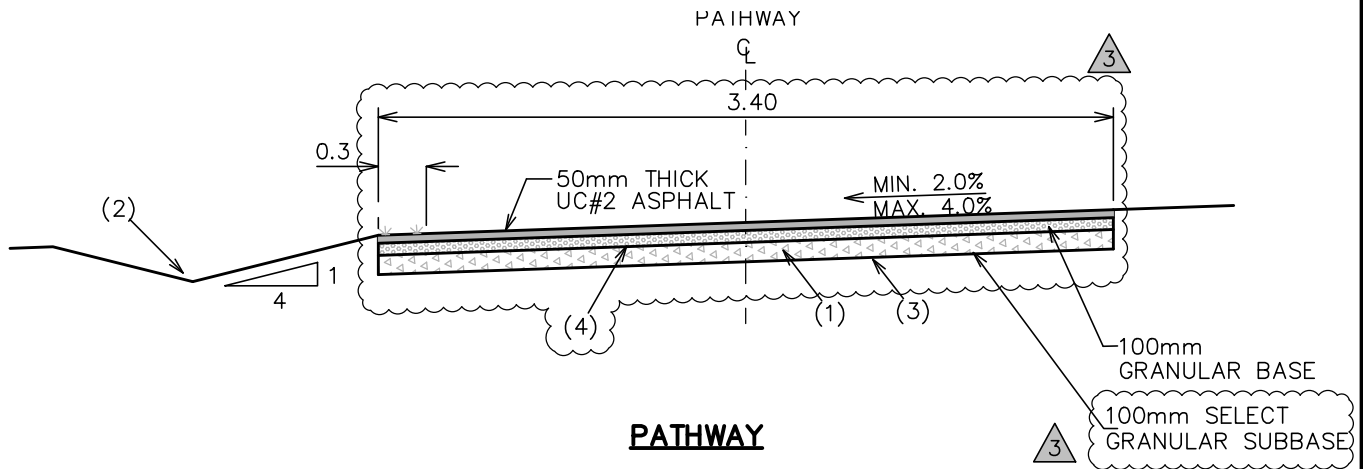

1. PATHWAY MAY CONSIST OF 3.0m ASPHALT PATHWAY (SSD-R.21.1) OR 1.5m CONCRETE SIDEWALK PLUS 1.5m CYCLING PATHWAY AS SPECIFIED BY THE CITY OF SURREY.
2. STATUTORY RIGHT-OF-WAY (SRW) MAY BE REQUIRED IF BOULEVARD WIDTH EXCEEDS TYPICAL ROAD DEDICATION AS SPECIFIED BY THE ENGINEER/APPROVING OFFICER.
3. SINGLE LOCKING BOLLARD AS PER SSD-R.22 CENTRED IN MULTI USE PATH REQUIRED AT INTERSECTIONS AND CURB RETURN DRIVEWAYS.
4. PEDESTRIAN LIGHTING REQUIRED ALONG PATHWAY.

3	APRIL 2020	SCOTT NEUMAN	All Dimensions Shown In Metres, Unless Otherwise Noted
2	JANUARY 2016	JAIME BOAN	
1	JANUARY 2004	KOK KUEN LI	
	Revision Date	Approved	Title PATHWAYS, NEXT-TO-ROAD MULTI-USE DETAIL
 <p>CITY OF SURREY the future lives here.</p>			<p>SUPPLEMENTARY STANDARD DRAWINGS</p> <p>Approved By : </p> <p>APRIL 2020 G.M. Engineering</p>
			DRAWING NUMBER SSD-R.21



NOTES:

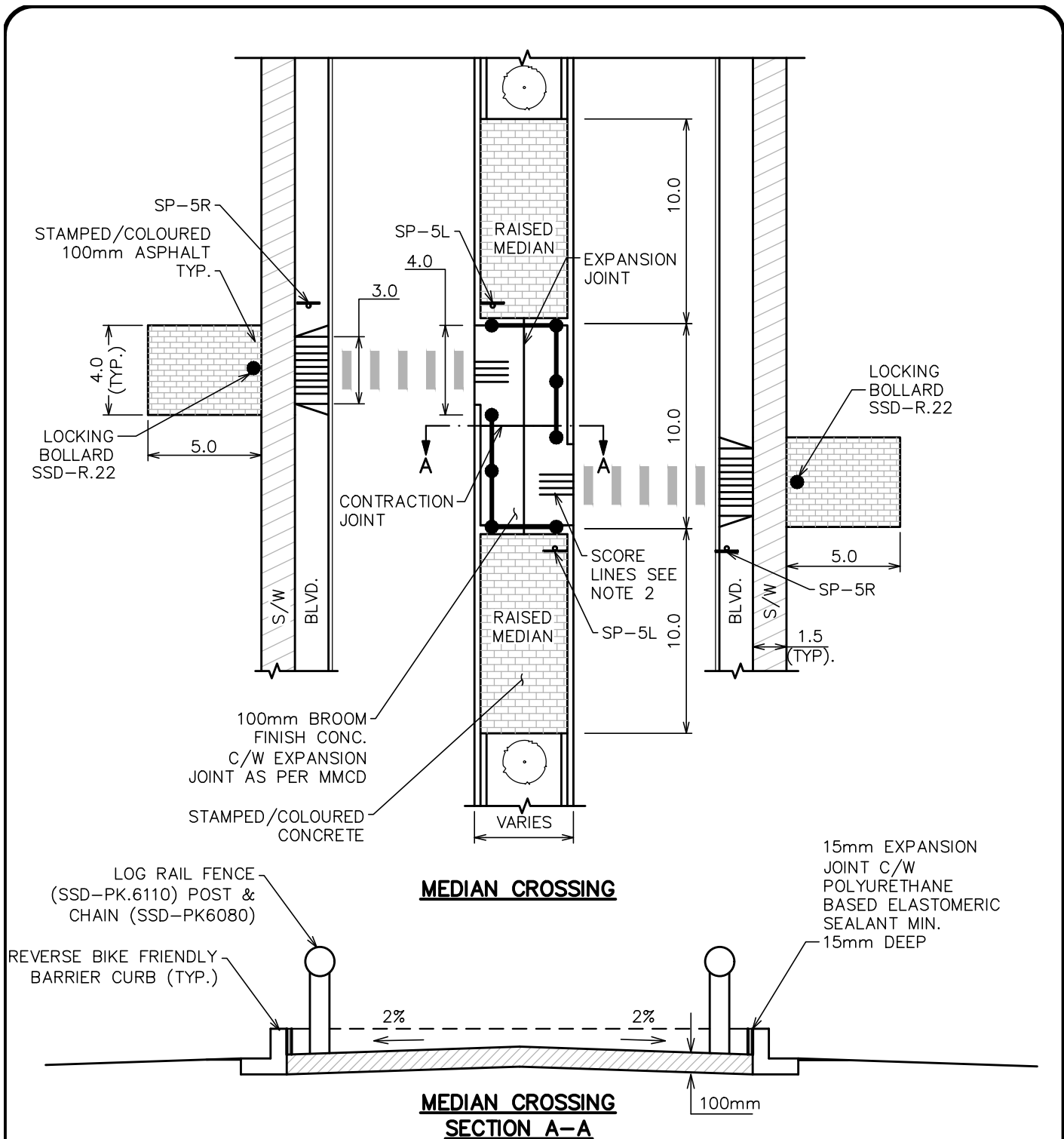

1. STRIPPING ZONE – STRIPPING DEPTH TO BE VARIABLE AND BASED ON ENGINEER’S RECOMMENDATIONS ON SITE. REPLACE WITH SELECT GRANULAR SUBBASE (75mm MINUS) TO 200mm DEPTH AND 75mm PIT-RUN GRAVEL BEYOND, COMPACTED TO 95% MODIFIED PROCTOR DENSITY.
2. DITCH (0.25m MIN. DEPTH TYP.) EXISTING TOPSOIL TO BE HYDROSEEDED.
3. GEOTEXTILE (NILEX No. 4545 OR EQUIVALENT)
4. MIL BLACK POLYETHYLENE SHEET.
5. EXPANSION & CONTRACTION JOINTS AS PER MMCD C3.

3	APRIL 2020	SCOTT NEUMAN	All Dimensions Shown In Metres, Unless Otherwise Noted
2	JULY 2016	JAIME BOAN	
1	JANUARY 2016	JAIME BOAN	
	Revision Date	Approved	Title PATHWAYS, MULTI-USE SECTION DETAILS
 <p style="text-align: center;">SUPPLEMENTARY STANDARD DRAWINGS</p>			Approved By :  APRIL 2020 G.M. Engineering
			DRAWING NUMBER SSD-R.21.1





NOTES:

1. DRAINAGE FEATURES IN THE MEDIAN AS REQUIRED.
2. SCORE LINES 40cm APART, USE 3/8" TROWEL, EDGE TO BE AS CLOSE AS FLUSH WITH BROOM FINISH (TYP.)

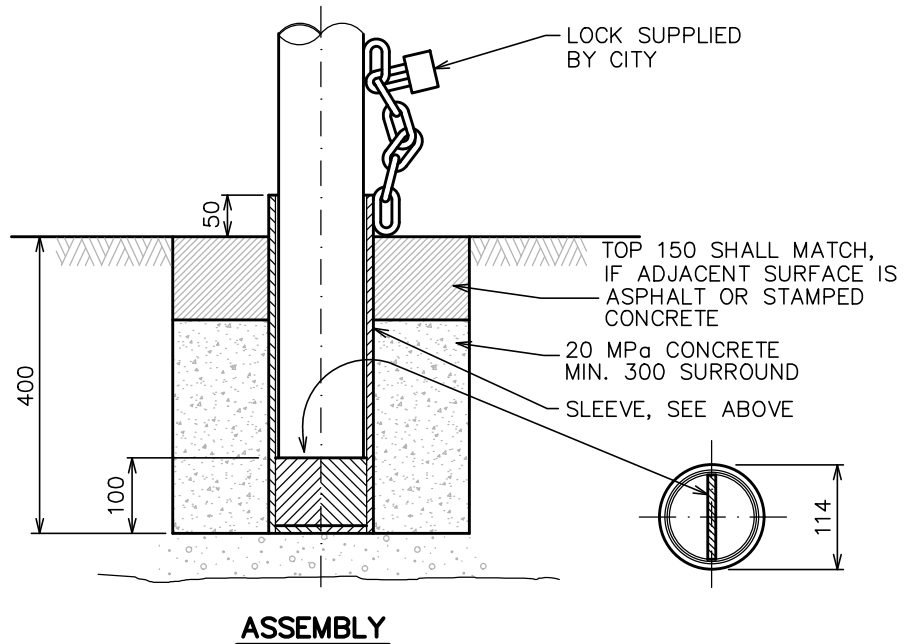
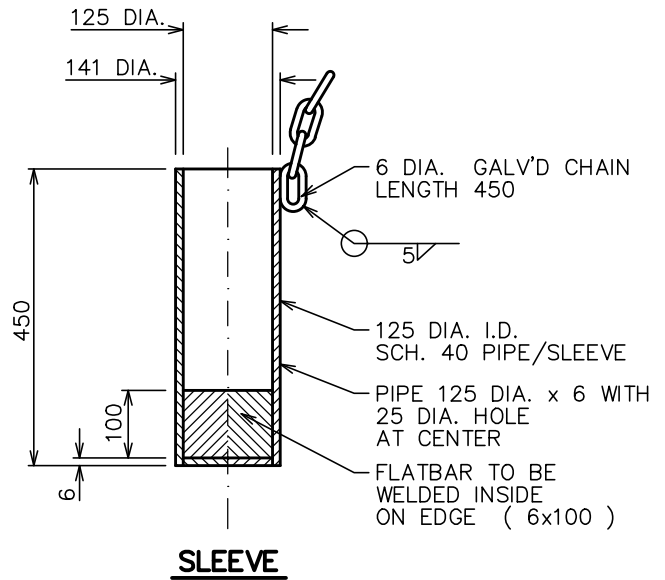
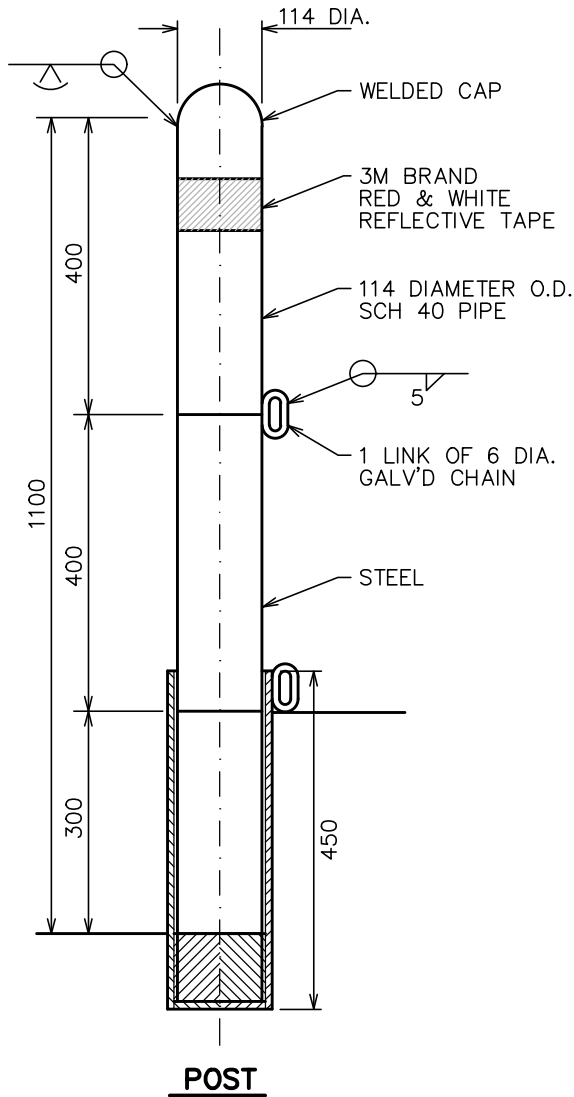
3	APRIL 2020	SCOTT NEUMAN	All Dimensions Shown In Metres, Unless Otherwise Noted
2	JANUARY 2016	JAIME BOAN	
1	MARCH 2004	KOK KUEN LI	
	Revision Date	Approved	Title PATHWAYS, MEDIAN MID BLOCK CROSSING DETAIL
 SUPPLEMENTARY STANDARD DRAWINGS			Approved By :  APRIL 2020 G.M. Engineering
			DRAWING NUMBER SSD-R.21.2



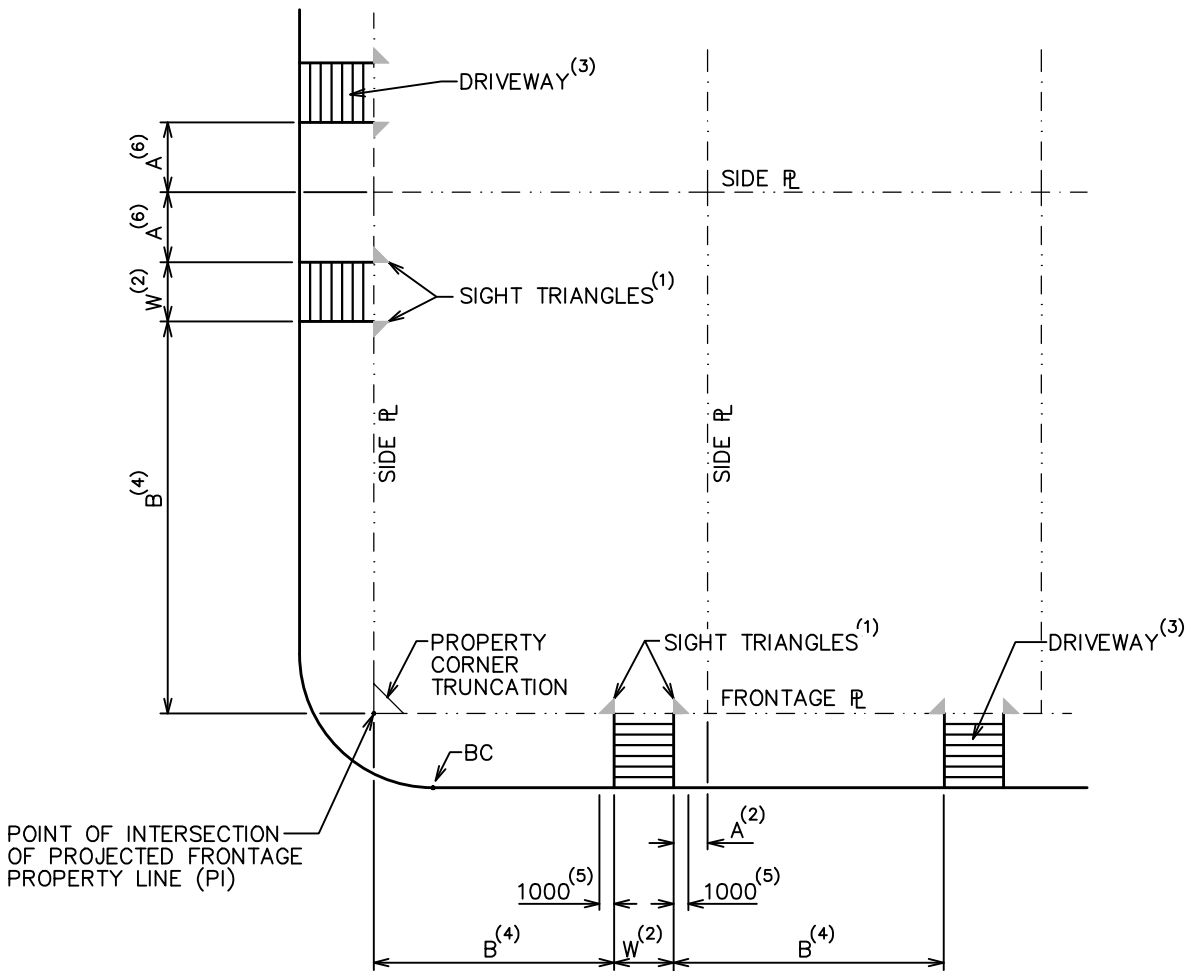

NOTE:
1. FINISH POWDER COATED WHITE.

3		All Dimensions Shown In Millimetres, Unless Otherwise Noted
2	APRIL 2020 SCOTT NEUMAN	
1	JANUARY 2016 JAIME BOAN	
	Revision Date Approved	Title PATHWAYS, LOCKING BOLLARD
 SUPPLEMENTARY STANDARD DRAWINGS		Approved By :  APRIL 2020 G.M. Engineering
		DRAWING NUMBER SSD-R.22



NOTES:

1. SIGHT TRIANGLE:
 - 1.0m X 1.0m FOR SINGLE RESIDENTIAL ZONES.
 - USE TAC GEOMETRIC DESIGN GUIDE FOR CANADIAN ROADS, THE LATEST EDITION.
 - OBSTRUCTION TO SIGHT (EG. LANDSCAPE, FENCES, SIGNS, ETC.) SHALL NOT BE HIGHER THAN 0.5m WITHIN THE SIGHT TRIANGLE.
2. FOR DIMENSION OF 'W' AND 'A', SEE TABLE ON FOR SSD-R24.
3. CORNER LOTS IN SINGLE FAMILY ZONE, DRIVEWAYS SHALL BE LOCATED NEAR SIDE PROPERTY LINE AND AWAY FROM INTERSECTION.
4. 'B' SHALL BE MIN. 9.0m FOR LOCAL ROADS, 25.0m FOR COLLECTOR ROADS, AND 50.0m FOR ARTERIAL ROADS. DRIVEWAY SPACING MAY BE REDUCED SUBJECT TO THE APPROVAL OF THE CITY OF SURREY.
5. THE FLARE IS NOT REQUIRED FOR ROLLOVER CURBS. FLARE IS NOT REQUIRED WHERE GRASS/LANDSCAPING ABUTS A SINGLE FAMILY RESIDENTIAL DRIVEWAY. FLARE NOT PERMITTED WITH PAIRED RESIDENTIAL DRIVEWAYS EXCEPT WHERE SIDEWALK ABUTS THE CURB TO MATCH EXISTING STANDARD.
6. FOR SINGLE FAMILY RESIDENTIAL ZONE DRIVEWAYS, THE SPACING 'B' MAY BE REDUCED TO THE MIN. 'A' ON EACH SIDE OF THE PROPERTY LINE BETWEEN DRIVEWAYS, TO ALLOW FOR PAIRED DRIVEWAYS.

3	APRIL 2020	SCOTT NEUMAN	All Dimensions Shown In Millimetres, Unless Otherwise Noted
2	JANUARY 2016	JAIME BOAN	
1	MARCH 2002		
	Revision Date	Approved	Title DRIVEWAYS, LOCATIONS & SPACING
 SUPPLEMENTARY STANDARD DRAWINGS			Approved By :  APRIL 2020 G.M. Engineering
			DRAWING NUMBER SSD-R.23

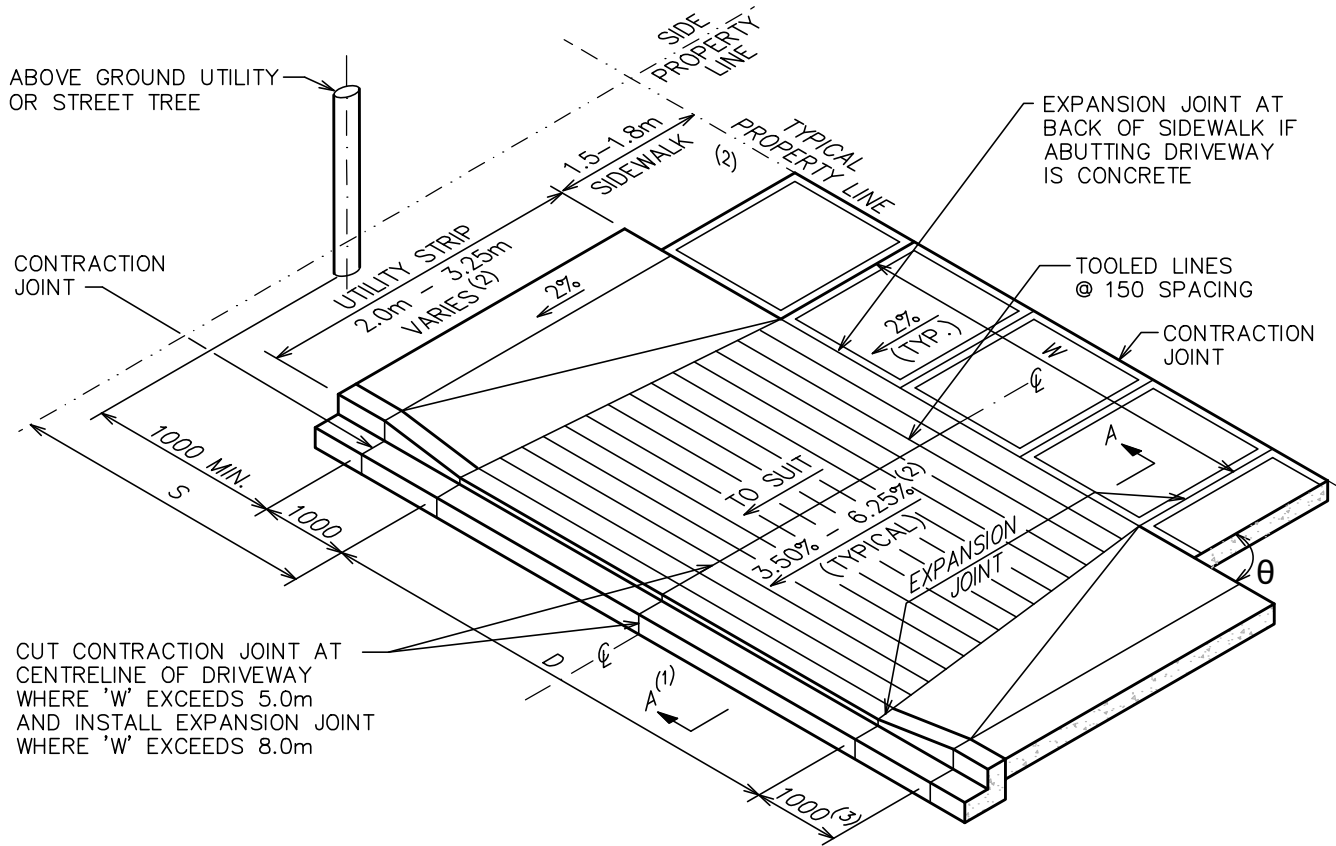



CUT CONTRACTION JOINT AT CENTRELINE OF DRIVEWAY WHERE 'W' EXCEEDS 5.0m AND INSTALL EXPANSION JOINT WHERE 'W' EXCEEDS 8.0m

ZONE	OPERATION	W		S	θ - MIN. ANGLE BTWN. THE FRONTAGE PROP. LINE AND THE EDGE OF DRIVEWAY (DEG.)	D
		MIN. (m)	STD. (m)			
SINGLE FAMILY RESIDENTIAL	N/A	4.5	6.0	1.4	90	6.0 LOCAL/COLLECTOR 7.2 ARTERIAL

NOTES:

1. FOR SECTION A-A REFER TO SSD-R.24.3
2. FOR UTILITY STRIP LESS THAN 2.0m, SIDEWALK SLOPE MUST REMAIN AT 2%
3. FLARE IS NOT PERMITTED FOR SINGLE FAMILY RESIDENTIAL UNLESS DIRECTED BY CITY OF SURREY.

4	APRIL 2020	SCOTT NEUMAN	All Dimensions Shown In Millimetres, Unless Otherwise Noted
3	JANUARY 2016	JAIME BOAN	
2	MARCH 2004	KOK KUEN LI	
	Revision Date	Approved	
			Title DRIVEWAYS, SINGLE FAMILY RESIDENTIAL LETDOWN
 <p>SUPPLEMENTARY STANDARD DRAWINGS</p>			Approved By : 
			APRIL 2020 G.M. Engineering
			DRAWING NUMBER SSD-R.24

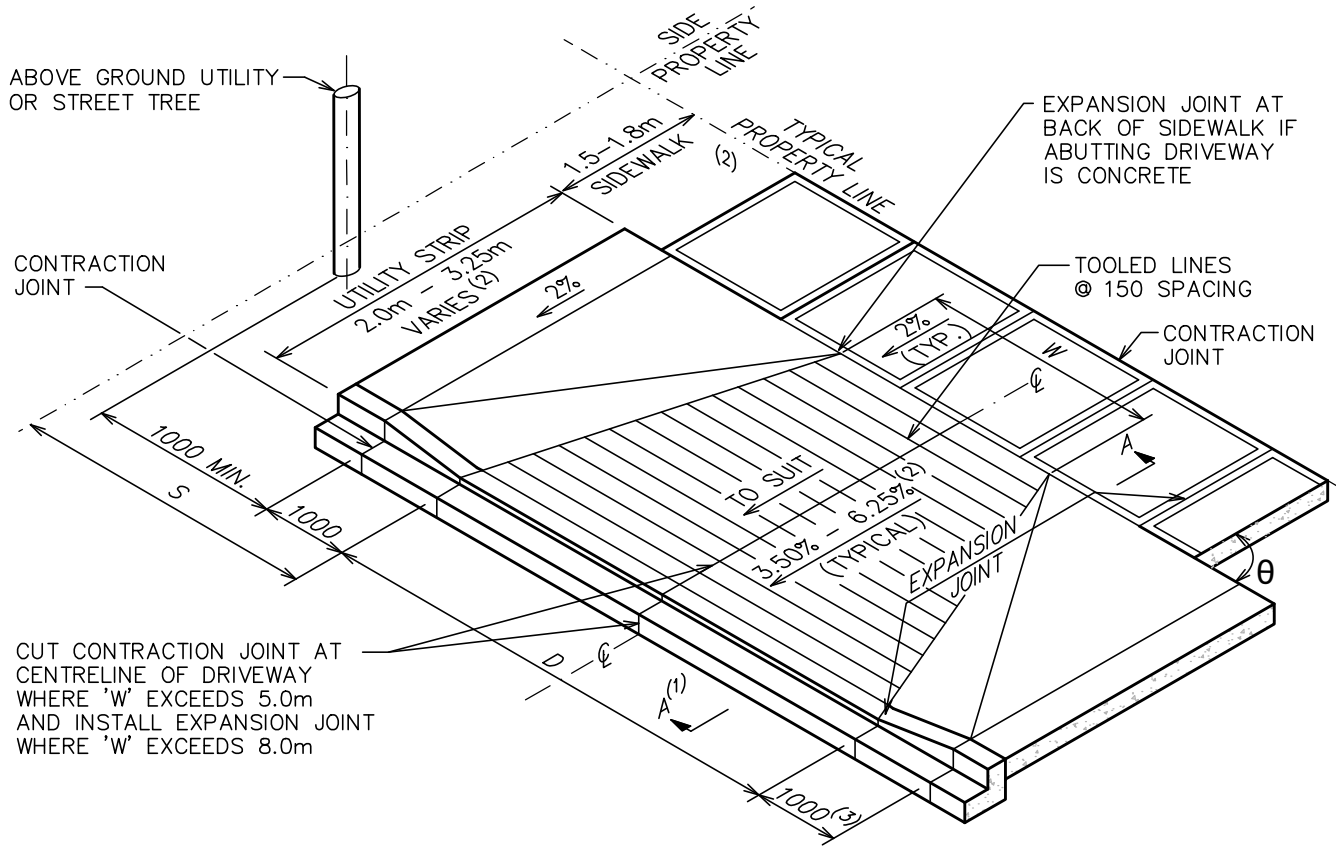

ZONE	OPERATION	W		S MIN. DISTANCE FROM SIDE PROPERTY LINE (m)	θ - MIN. ANGLE BTWN. THE FRONTAGE PROP. LINE AND THE EDGE OF DRIVEWAY (DEG.)	D
		MIN. (m)	STD. (m)			
MULTI FAMILY RESIDENTIAL	TWO WAY	N/A	7.3	2.0	90	9.7
	ONE WAY	N/A	4.5	2.0	45	
LANE	RESIDENTIAL	N/A	7.3	2.0	90	9.7
	COMMERCIAL	N/A	9.3	2.0	45	
COMMERCIAL	TWO WAY	7.3	9.0	2.0	90	11.4
	ONE WAY	N/A	4.5	2.0	45	
INDUSTRIAL	TWO WAY	9.0	11.0	2.0	90	13.4
	ONE WAY	N/A	5.0	2.0	30	

NOTES:

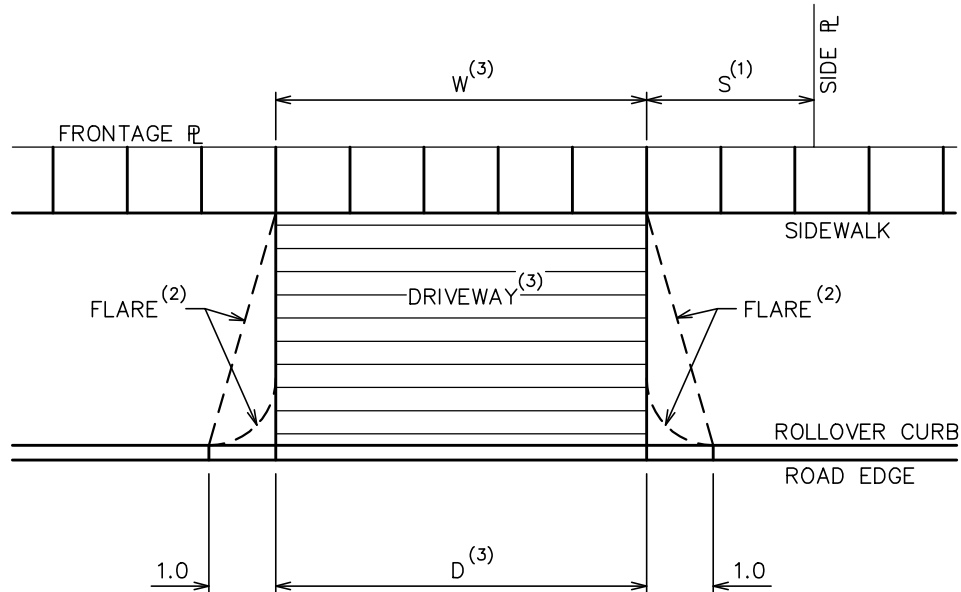

- FOR SECTION A-A REFER TO SSD-R.24.3
- FOR UTILITY STRIP LESS THAN 2.0m, SIDEWALK SLOPE MUST REMAIN AT 2%
- FLARE IS NOT PERMITTED FOR SINGLE FAMILY RESIDENTIAL UNLESS DIRECTED BY CITY OF SURREY.

3	APRIL 2020	SCOTT NEUMAN	All Dimensions Shown In Millimetres, Unless Otherwise Noted
2	JANUARY 2016	JAIME BOAN	
1	MARCH 2004	KOK KUEN LI	
	Revision Date	Approved	Title DRIVEWAYS, MULTI-FAMILY/COMMERCIAL/INDUSTRIAL LETDOWN
			Approved By :
SUPPLEMENTARY STANDARD DRAWINGS			DRAWING NUMBER SSD-R.24.1
APRIL 2020			G.M. Engineering



NOTES:

1. SEE TABLES ON SSD-R.24 AND SSD-R.24.1 FOR MINIMUM DISTANCE FROM SIDE PROPERTY LINE.
2. FLARE IS NOT PERMITTED FOR SINGLE FAMILY ZONES ON LOCAL OR COLLECTOR ROADS.
3. SEE TABLES ON SSD-R.24 AND SSD-R.24.1 FOR WIDTH OF DRIVEWAY.

3		All Dimensions Shown In Metres, Unless Otherwise Noted
2	APRIL 2020 SCOTT NEUMAN	
1	JANUARY 2016 JAIME BOAN	
	Revision Date Approved	Title DRIVEWAYS, CROSSING FOR ROLLOVER CURBS DETAILS
 SUPPLEMENTARY STANDARD DRAWINGS		Approved By :  APRIL 2020 G.M. Engineering
		DRAWING NUMBER SSD-R.24.2

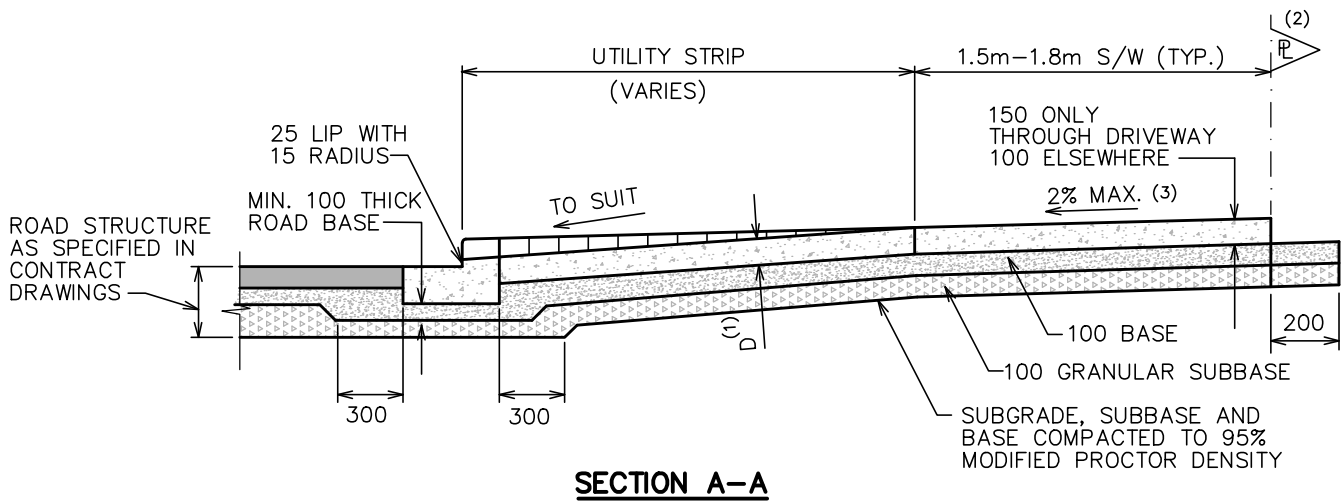

NOTES:

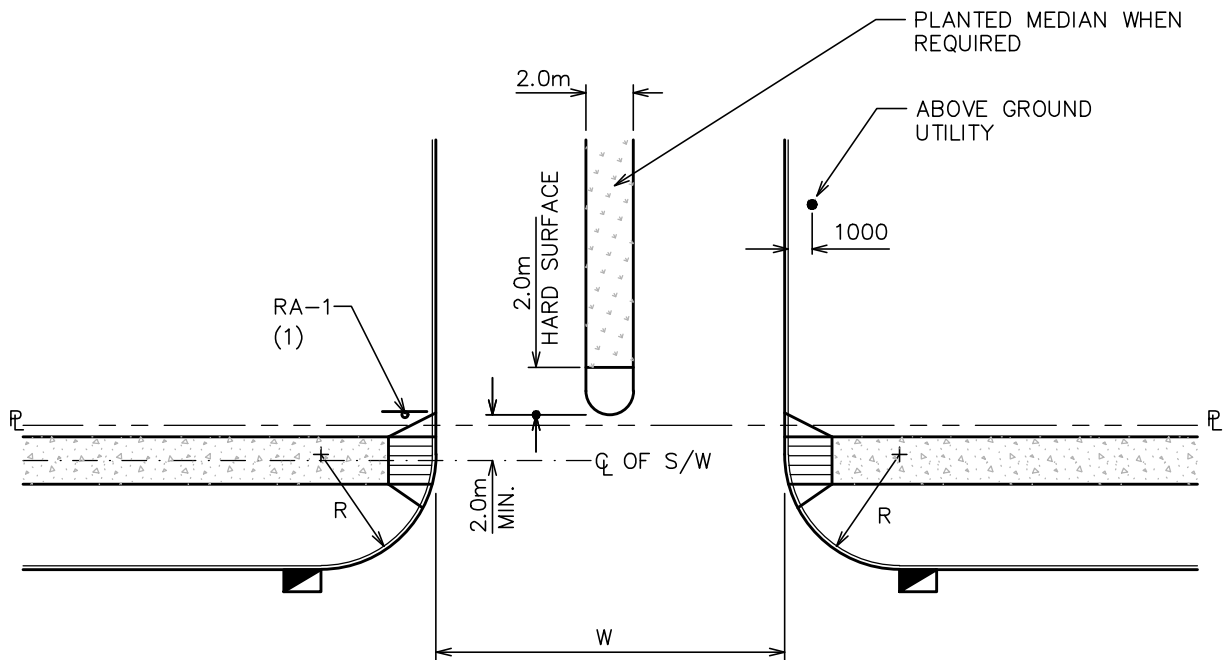

1. "D"=200 EXCEPT FOR SINGLE FAMILY RESIDENTIAL WHERE "D"=150.
2. WHERE PL IS FURTHER BACK FROM SIDEWALK GRADE TO SUIT TOWARD DRIVEWAY, ENSURE POSITIVE DRAINAGE AWAY FROM PROPERTY.
3. IF SIDEWALK ADJACENT TO CURB, LETDOWN GRADE MAY VARY FROM 2.0%

3	APRIL 2020	SCOTT NEUMAN	All Dimensions Shown In Millimetres, Unless Otherwise Noted
2	JANUARY 2016	JAIME BOAN	
1	MAY 2008	JAIME BOAN	Title DRIVEWAY LETDOWNS, CROSS SECTION
	Revision Date	Approved	
CITY OF SURREY <small>the future lives here.</small>			Approved By : APRIL 2020 G.M. Engineering
			DRAWING NUMBER SSD-R.24.3



ZONE	DRIVEWAY TYPE	W		R	
		MIN. (m)	MAX. (m)	MIN.	MAX.
COMMERCIAL, MULTI-FAMILY	TWO WAY	7.3	9.0 (EXCLUDING MEDIAN)	7.0	9.0
	ONE WAY	4.5	5.5		
INDUSTRIAL ZONE	TWO WAY	7.3	11.0 (EXCLUDING MEDIAN)	9.0	12.0
	ONE WAY	4.5	6.0		

NOTES: 1) SIGN TO BE INSTALLED AND MAINTAINED BY PROPERTY OWNER

3		All Dimensions Shown In Millimetres, Unless Otherwise Noted
2	APRIL 2020 SCOTT NEUMAN	
1	JANUARY 2016 JAIME BOAN	
	Revision Date Approved	Title DRIVEWAYS, CURB RETURN CROSSING
 SUPPLEMENTARY STANDARD DRAWINGS		Approved By :  APRIL 2020 G.M. Engineering
		DRAWING NUMBER SSD-R.25

AREA TO BE CONCRETE FOR PEDESTRIAN CONTROL BUTTON, IF REQUIRED

NOTES: (1) STANDARD RAMP LENGTH: 2.0m AT CENTRE OF RAMP. RECOMMENDED RAMP SLOPE: 7.0% ± 1.0%. MAX. SLOPE 8.0% (1:12) WHERE TOPOGRAPHY PERMITS. ADJUST LENGTH OF RAMP AS REQUIRED WHEN SITE CONDITIONS DO NOT PERMIT TYPICAL LAYOUT. CONTACT CITY ENGINEER FOR APPROVAL OF DESIGN.
 (2) IF DIFFERENT BLVD WIDTHS, USE NARROWER BLVD STD. LETDOWN DRAWINGS.

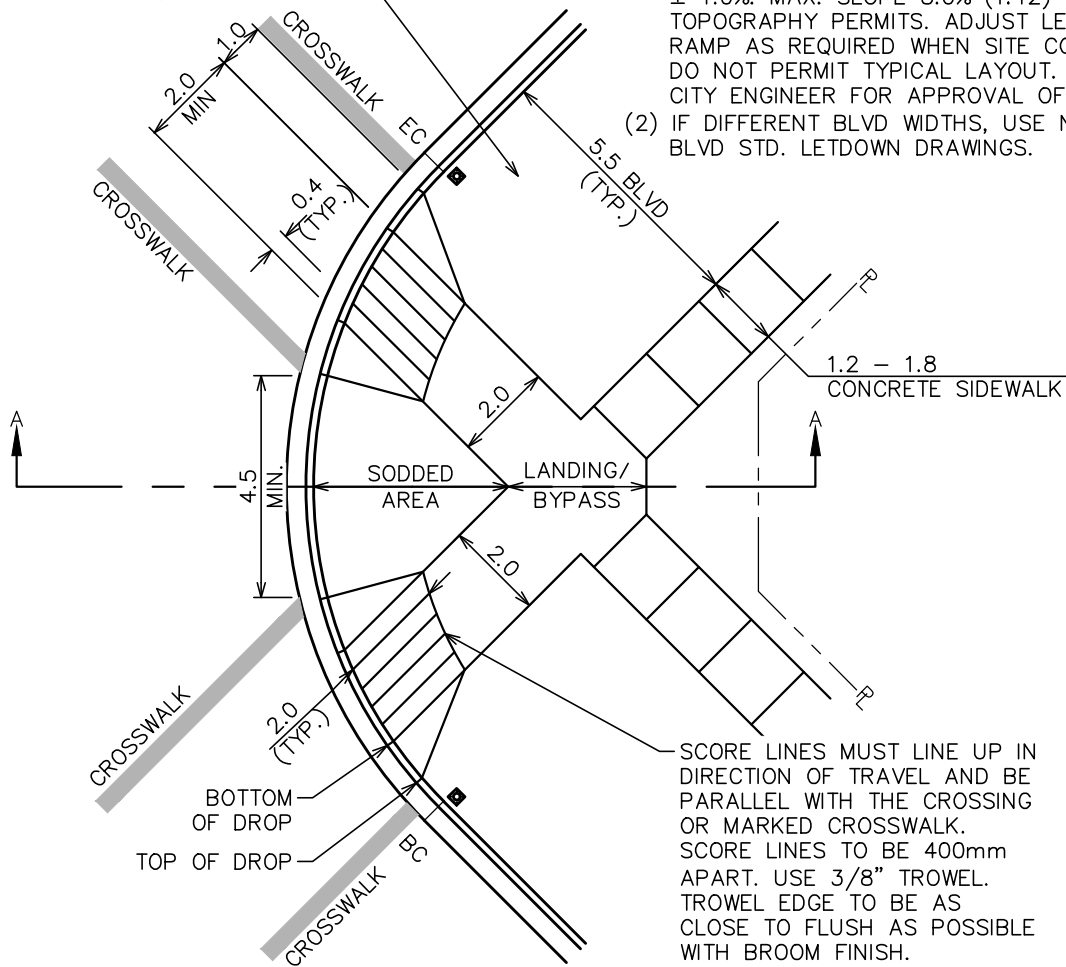

SPLIT LETDOWN

RAMP SHALL BE UNIFORM THICKNESS OF 100mm FROM TOP OF LIP TO TOP OF SIDEWALK

TRANSITION FROM CURB TO RAMP SHALL BE FLUSH

BARRIER CURB & GUTTER

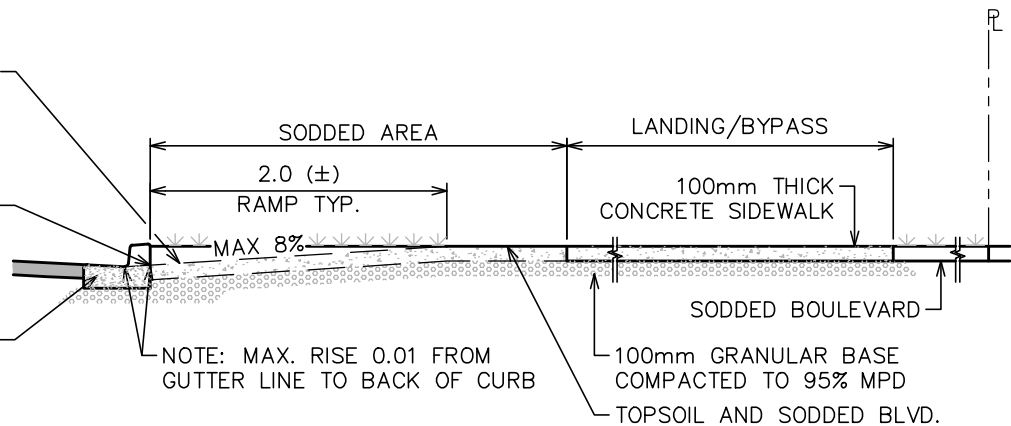

SECTION A-A CURB RAMP

3		
2	APRIL 2020	SCOTT NEUMAN
1	JANUARY 2016	JAIME BOAN
	Revision Date	Approved

All Dimensions Shown In Metres, Unless Otherwise Noted

Title **SPLIT LETDOWN AT INTERSECTION. BOULEVARD GREATER THAN 4.50m**

SUPPLEMENTARY STANDARD DRAWINGS

Approved By : *[Signature]*
 APRIL 2020 G.M. Engineering

DRAWING NUMBER **SSD-R.26**

CONCRETE AREA FOR PEDESTRIAN CONTROL BUTTON, IF REQUIRED

NOTE: STANDARD RAMP LENGTH: 2.0m AT CENTRE OF RAMP. RECOMMENDED RAMP SLOPE: 7.1% ± 1.2%. MAX. SLOPE 8.3% (1:12) WHERE TOPOGRAPHY PERMITS. ADJUST LENGTH OF RAMP AS REQUIRED WHEN SITE CONDITIONS DO NOT PERMIT TYPICAL LAYOUT. CONTACT CITY ENGINEER FOR APPROVAL OF DESIGN.

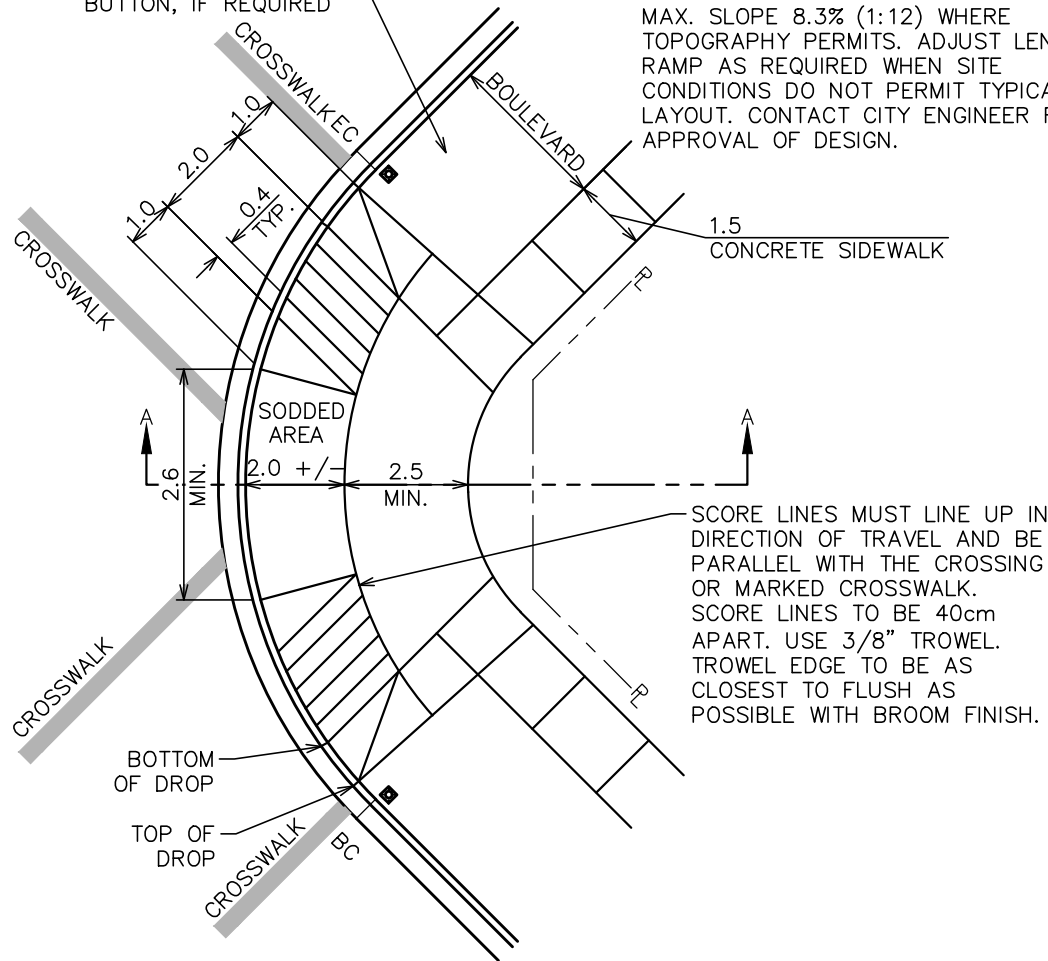

SINGLE RAMP

RAMP SHALL BE UNIFORM THICKNESS OF 100mm FROM TOP OF LIP TO TOP OF SIDEWALK

TRANSITION FROM CURB TO RAMP SHALL BE FLUSH

BARRIER CURB & GUTTER

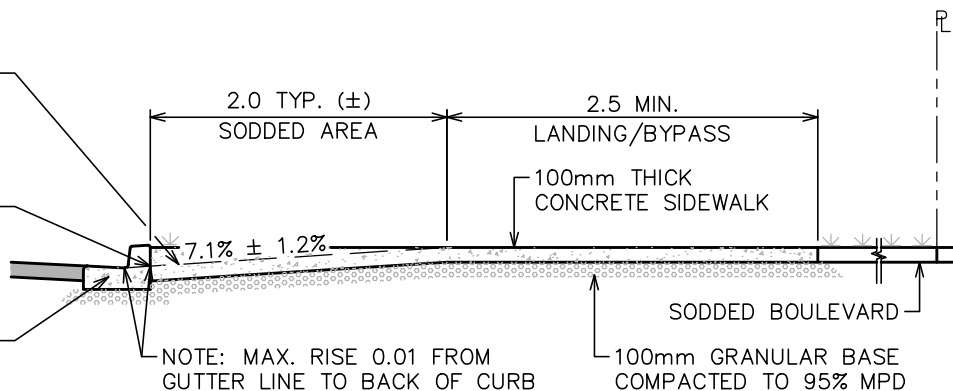

SECTION A-A CURB RAMP

3		
2	APRIL 2020	SCOTT NEUMAN
1	JANUARY 2016	JAIME BOAN
	Revision Date	Approved

All Dimensions Shown In Metres, Unless Otherwise Noted

Title **SPLIT LETDOWN AT INTERSECTION. BOULEVARD 3.00-4.49m**



Approved By : *[Signature]*
APRIL 2020 G.M. Engineering

DRAWING NUMBER **SSD-R.26.1**

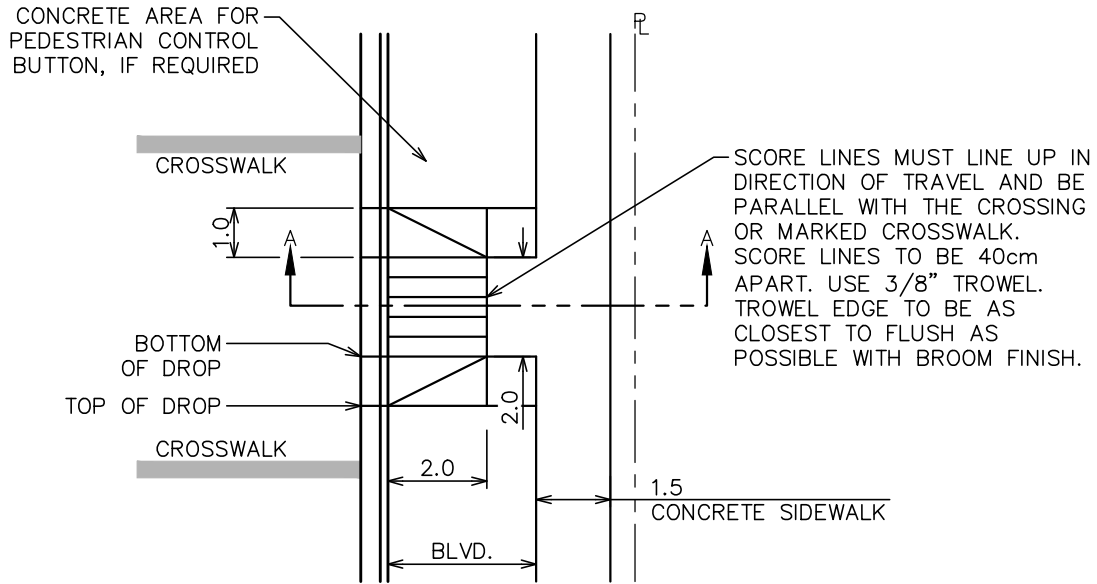

NOTE: STANDARD RAMP LENGTH: 2.0m AT CENTRE OF RAMP.
 RECOMMENDED RAMP SLOPE: 7.1% ± 1.2%.
 MAX. SLOPE 8.3% (1:12) WHERE TOPOGRAPHY PERMITS. ADJUST
 LENGTH OF RAMP AS REQUIRED WHEN SITE CONDITIONS DO NOT
 PERMIT TYPICAL LAYOUT. CONTACT CITY ENGINEER FOR APPROVAL
 OF DESIGN.

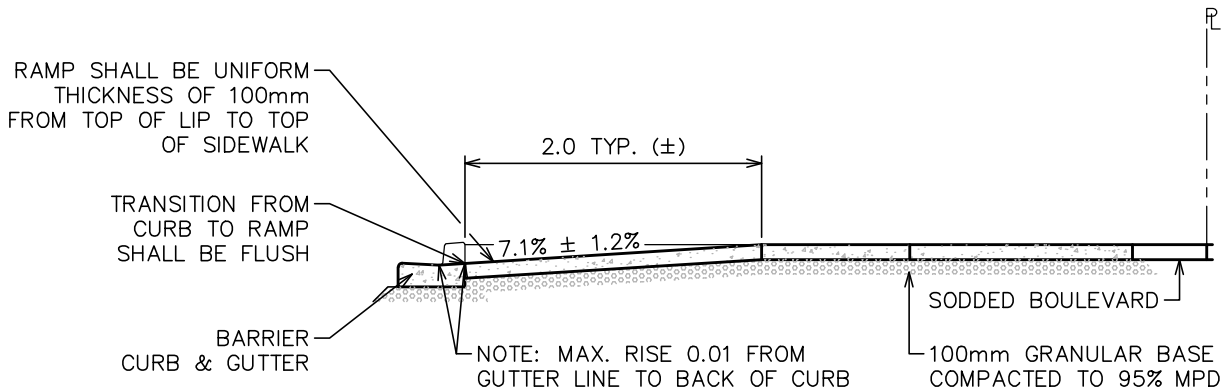

SINGLE RAMP



SECTION A-A CURB RAMP

3			All Dimensions Shown In Metres, Unless Otherwise Noted
2	APRIL 2020	SCOTT NEUMAN	
1	JANUARY 2016	JAIME BOAN	
	Revision Date	Approved	Title SINGLE RAMP LETDOWN WITH PARALLEL SCORING
 <p>CITY OF SURREY the future lives here.</p>			Approved By :  APRIL 2020 G.M. Engineering
SUPPLEMENTARY STANDARD DRAWINGS			DRAWING NUMBER SSD-R.26.2

CONCRETE AREA FOR PEDESTRIAN CONTROL BUTTON, IF REQUIRED

NOTE: STANDARD RAMP LENGTH: 2.0m AT CENTRE OF RAMP. RECOMMENDED RAMP SLOPE: 7.1% ± 1.2%. MAX. SLOPE 8.3% (1:12) WHERE TOPOGRAPHY PERMITS. ADJUST LENGTH OF RAMP AS REQUIRED WHEN SITE CONDITIONS DO NOT PERMIT TYPICAL LAYOUT. CONTACT CITY ENGINEER FOR APPROVAL OF DESIGN.

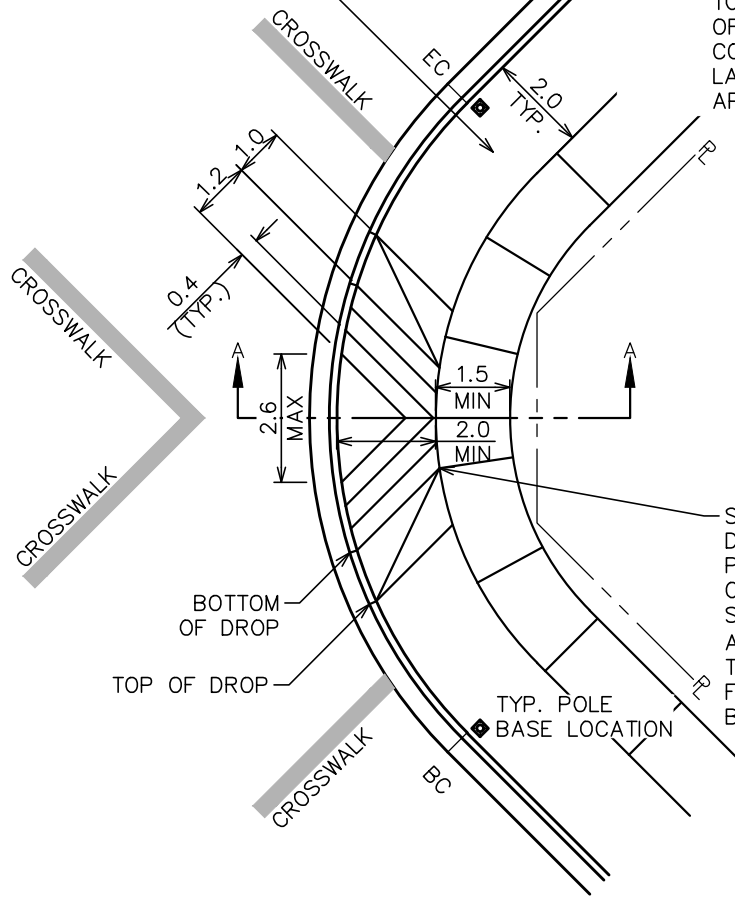

SCORE LINES MUST LINE UP IN DIRECTION OF TRAVEL AND BE PARALLEL WITH THE CROSSING OR MARKED CROSSWALK. SCORE LINES TO BE 40cm APART. USE 3/8" TROWEL. TROWEL EDGE TO BE AS FLUSH AS POSSIBLE WITH BROOM FINISH.

SINGLE RAMP

RAMP SHALL BE UNIFORM THICKNESS OF 100mm FROM TOP OF LIP TO TOP OF SIDEWALK

TRANSITION FROM CURB TO RAMP SHALL BE FLUSH

BARRIER CURB & GUTTER

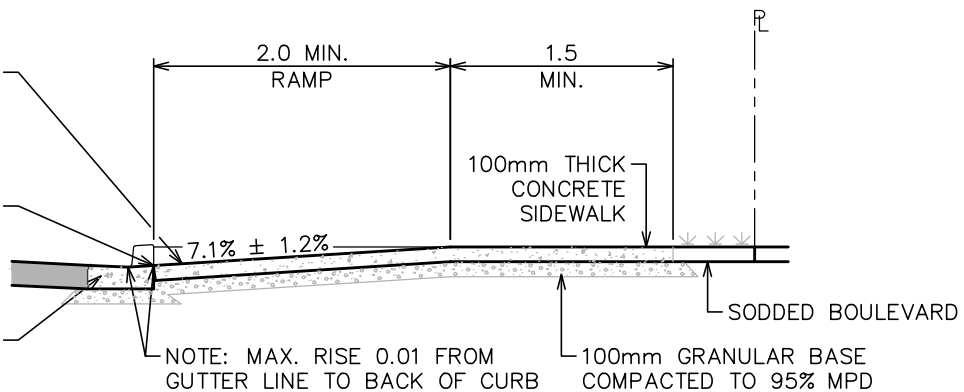

SECTION A-A CURB RAMP

3		
2	APRIL 2020	SCOTT NEUMAN
1	JANUARY 2016	JAIME BOAN
	Revision Date	Approved

All Dimensions Shown In Metres, Unless Otherwise Noted

Title **SINGLE LETDOWN AT INTERSECTION. BOULEVARD LESS THAN 2.99m**



Approved By : *[Signature]*
APRIL 2020 G.M. Engineering

DRAWING NUMBER **SSD-R.26.3**

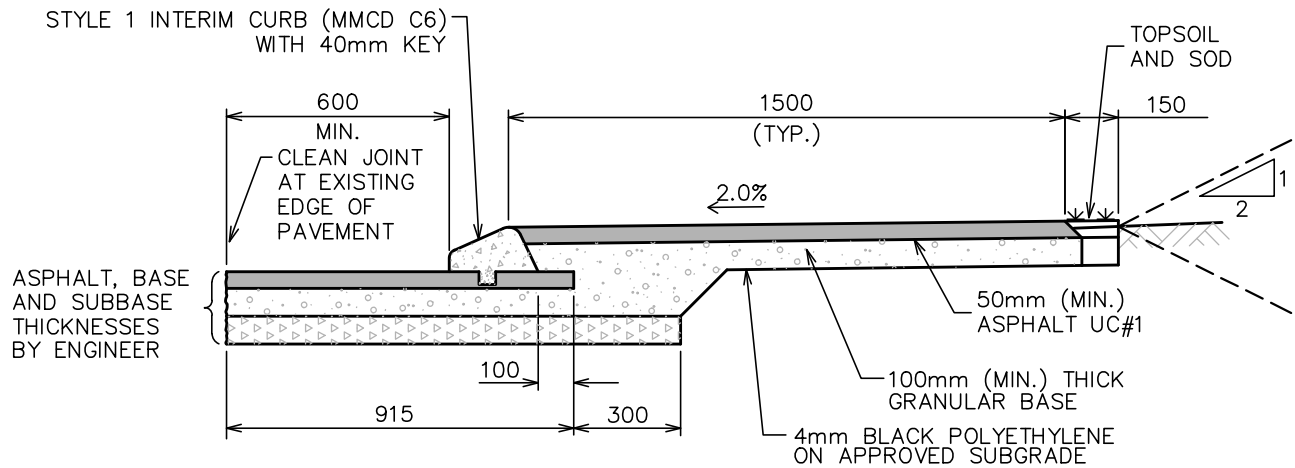

ELEVATED ASPHALT SIDEWALK

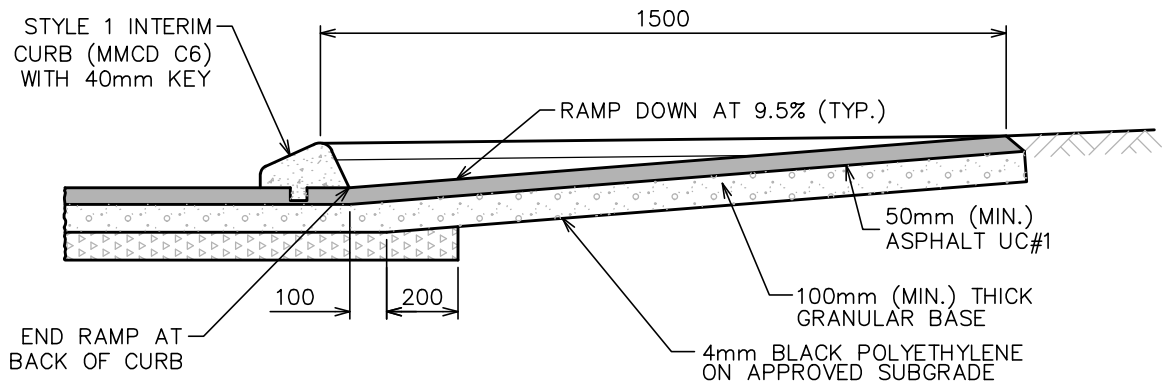

**ASPHALT SIDEWALK AT
WHEELCHAIR RAMP**

3			All Dimensions Shown In Millimetres, Unless Otherwise Noted
2	APRIL 2020	SCOTT NEUMAN	
1	JANUARY 2016	JAIME BOAN	Title SIDEWALKS, INTERIM ASPHALT
	Revision Date	Approved	
			Approved By :
SUPPLEMENTARY STANDARD DRAWINGS			APRIL 2020 G.M. Engineering
			DRAWING NUMBER SSD-R.27

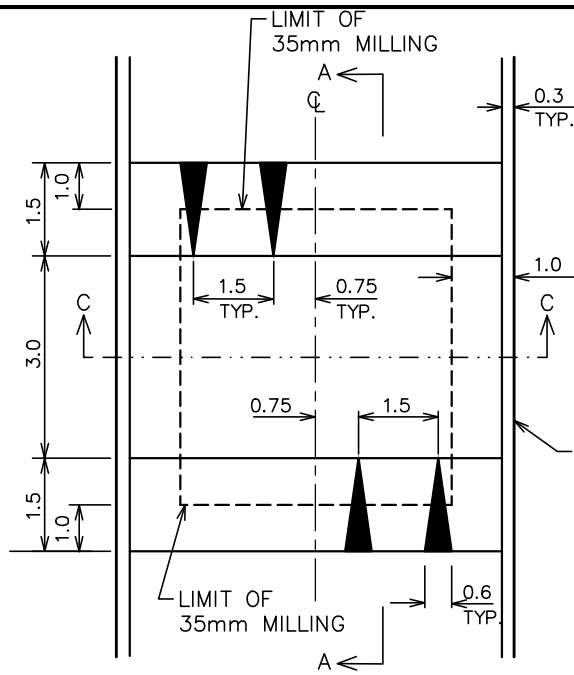

SPEED TABLE⁽¹⁾

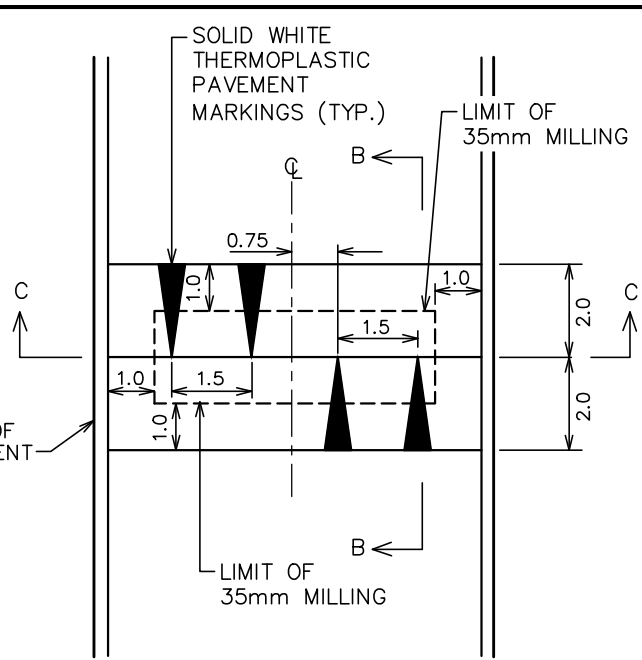

SPEED HUMP⁽²⁾

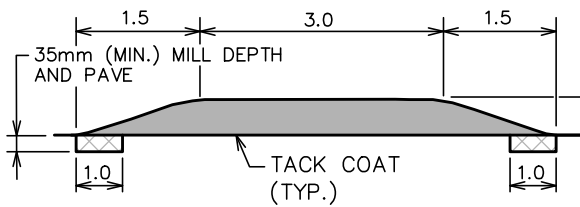

**SPEED TABLE
SECTION A-A**

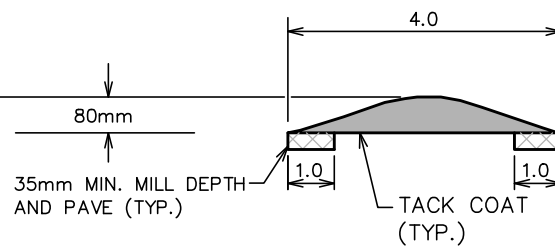

**SPEED HUMP
SECTION B-B**

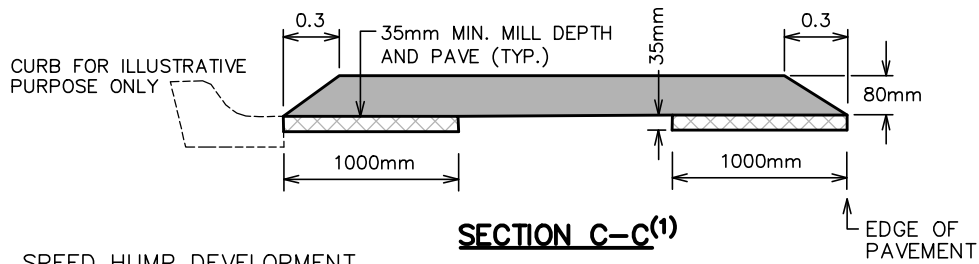

SECTION C-C⁽¹⁾

SINUSOIDAL SPEED HUMP DEVELOPMENT

DISTANCE(m)	0.000	0.125	0.250	0.375	0.500	0.625	0.750	0.875	1.000	1.125	1.250	1.375	1.500	1.625	1.750	1.875	2.000
FINISHED HEIGHT(mm)	0	1	3	7	12	18	25	32	40	48	55	62	68	73	77	79	80

- NOTES: (1) USE SSD-R.28.1 SECTION A-A, FOR USE OF SPEED TABLE AS RAISED CROSSWALK.
 (2) SINGLE ARROW PER DIRECTION ONLY FOR SPEED HUMPS IN LANES.
 (3) SPEED HUMP TABLE TO BE SURVEYED, TO ENSURE DEVELOPMENT.

3			All Dimensions Shown In Metres, Unless Otherwise Noted
2	APRIL 2020	SCOTT NEUMAN	
1	JANUARY 2016	JAIME BOAN	
	Revision Date	Approved	Title
			TRAFFIC CALMING, SPEED HUMP AND TABLE
			Approved By :
			APRIL 2020
			G.M. Engineering
			DRAWING NUMBER
			SSD-R.28



SUPPLEMENTARY
STANDARD
DRAWINGS

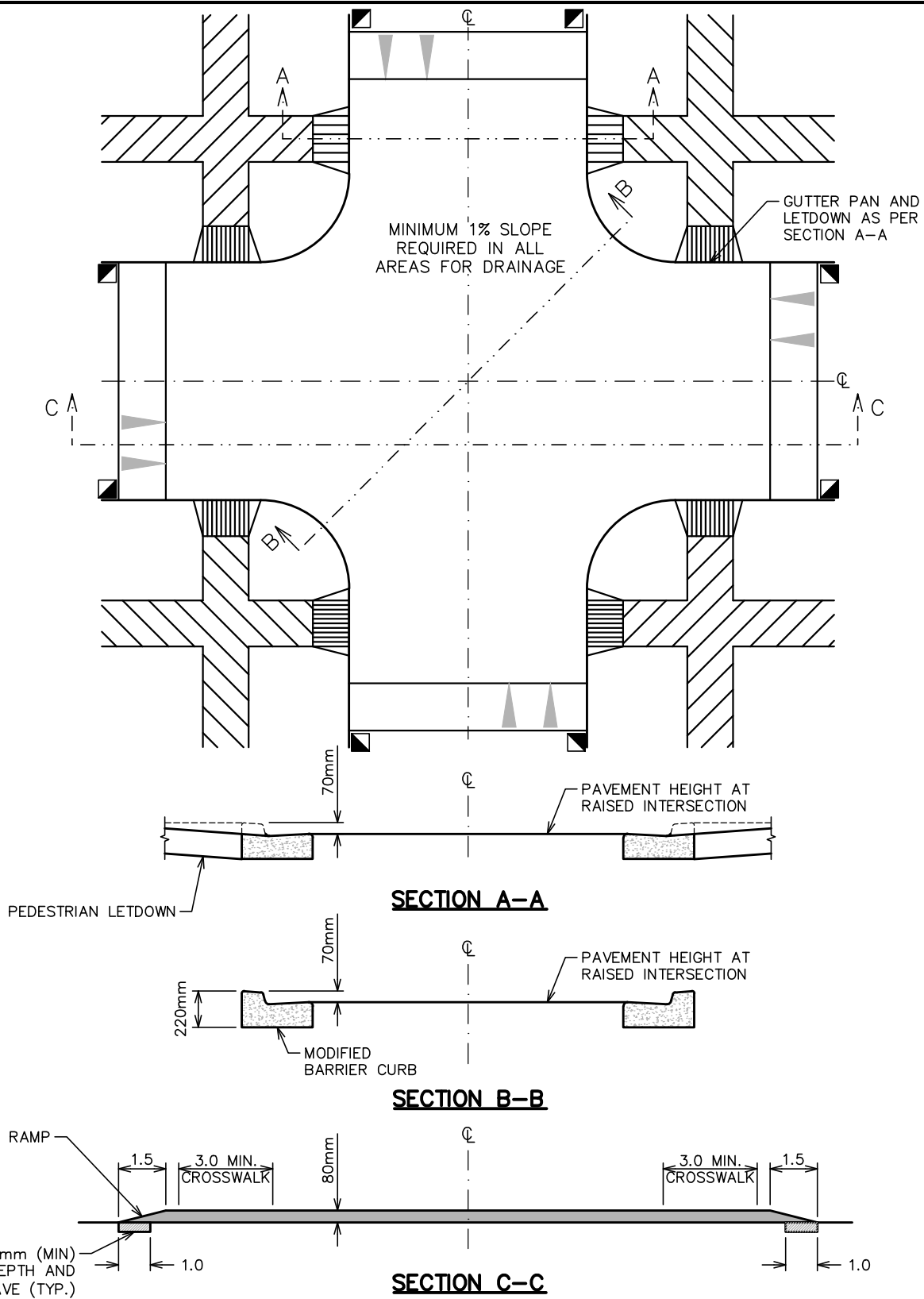

3		
2	APRIL 2020	SCOTT NEUMAN
1	JANUARY 2016	JAIME BOAN
	Revision Date	Approved

All Dimensions Shown In Metres, Unless Otherwise Noted

Title **TRAFFIC CALMING, RAISED INTERSECTION DETAILS**

SUPPLEMENTARY STANDARD DRAWINGS

Approved By :

APRIL 2020 G.M. Engineering

DRAWING NUMBER
SSD-R.28.1

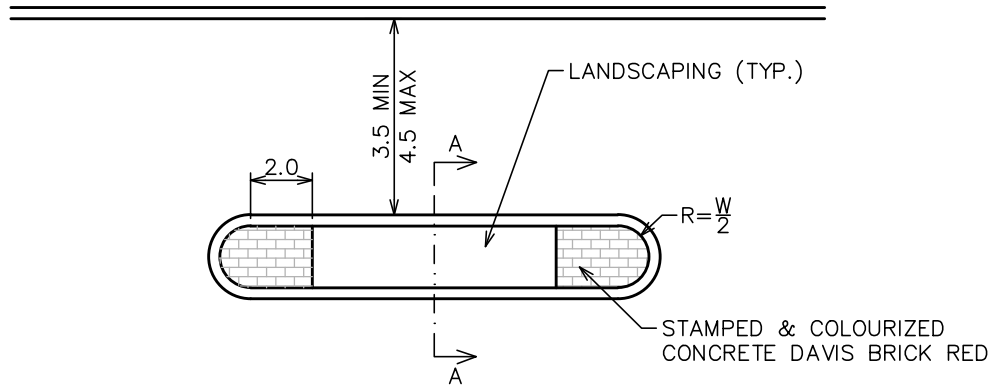

MEDIAN ISLAND

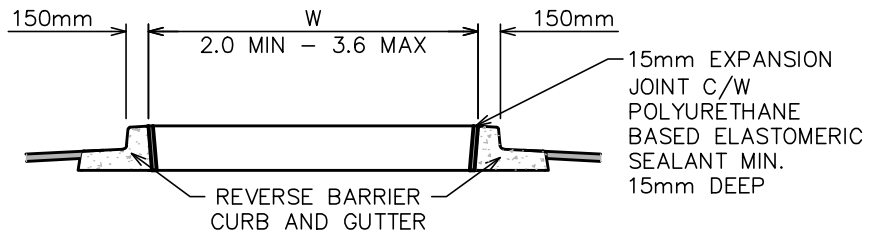

SECTION A-A

- NOTES: (1) THE MAXIMUM LENGTH OF THE MEDIAN ISLAND IS AFFECTED BY ADJACENT DRIVEWAY AND INTERSECTION LOCATIONS.
 (2) ADDITIONAL STOPPING PROHIBITED SIGNS (RB-55) MAY BE REQUIRED.

3			All Dimensions Shown In Metres, Unless Otherwise Noted
2	APRIL 2020	SCOTT NEUMAN	
1	JANUARY 2016	JAIME BOAN	
	Revision Date	Approved	Title TRAFFIC CALMING, TYPICAL RAISED MEDIAN
		SUPPLEMENTARY STANDARD DRAWINGS	Approved By : APRIL 2020 G.M. Engineering
			DRAWING NUMBER SSD-R.28.2

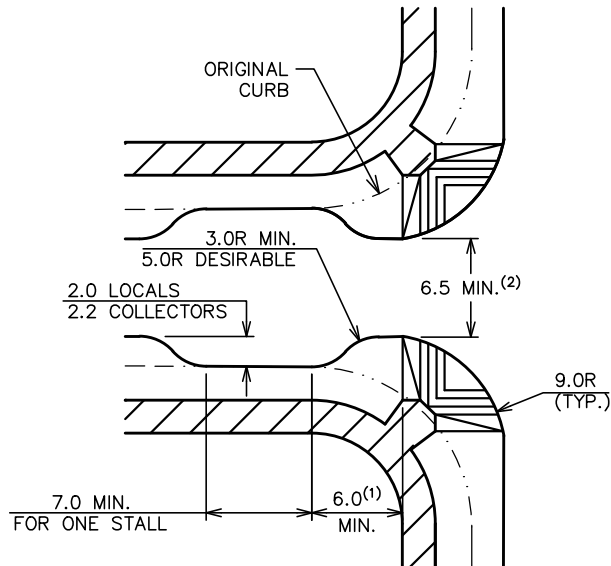

INTERSECTION CURB EXTENSION DETAILS

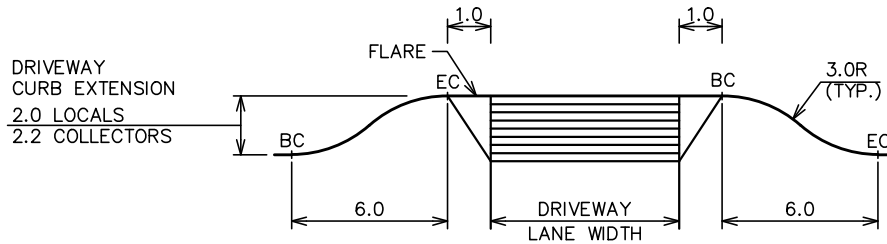

DRIVEWAY/LANE DETAIL

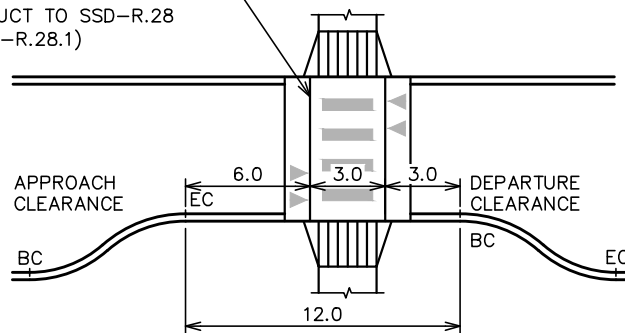

OPTIONAL RAISED CROSSWALK WITH RAISED CURB (CONSTRUCT TO SSD-R.28 AND SSD-R.28.1)



MIDBLOCK CROSSING DETAIL

NOTES:

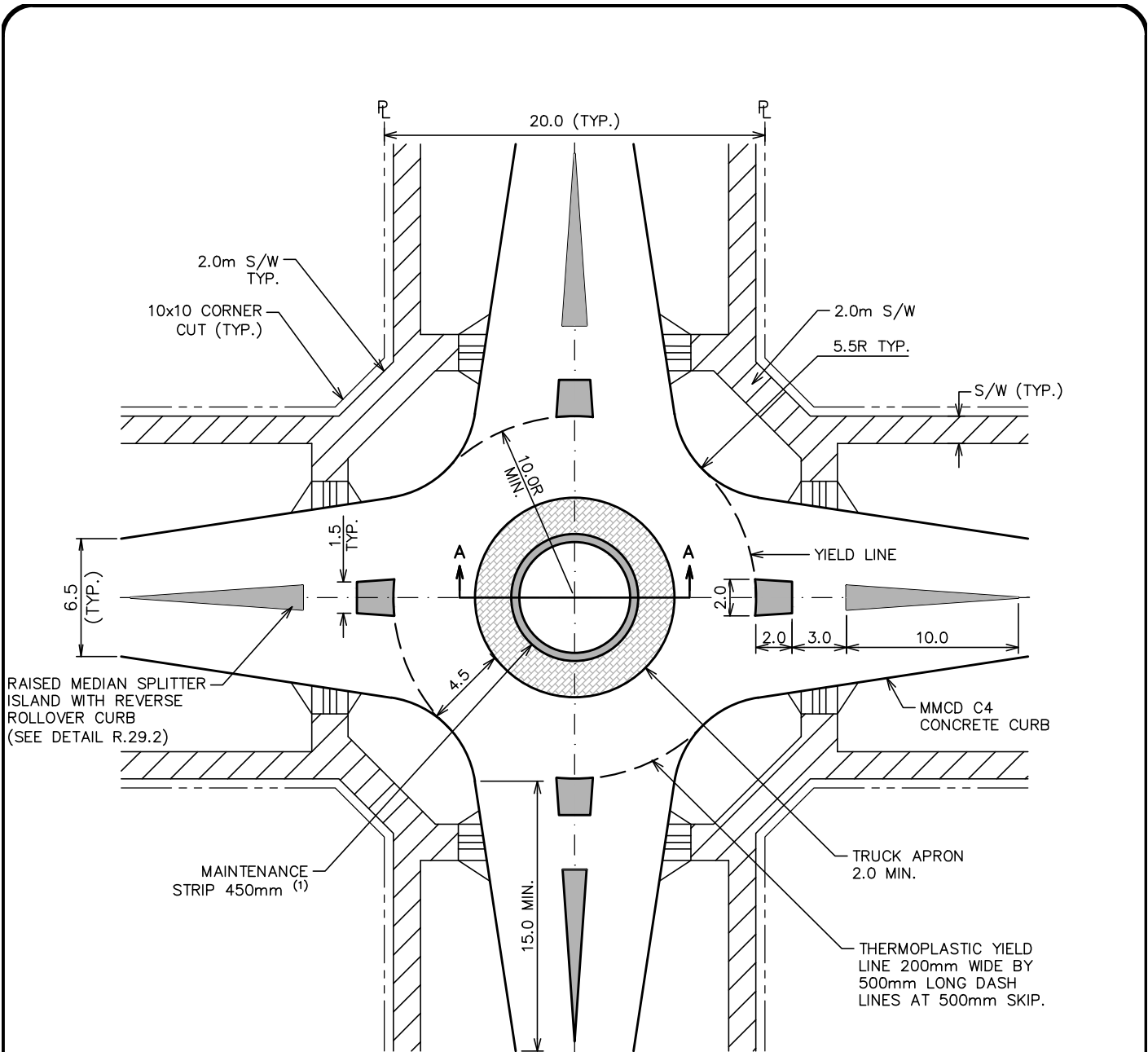

1. VARY AS REQUIRED TO MEET STOPPING SIGHT DISTANCE.
2. MINIMAL INCREASES TO 8.5m FOR LOCAL TO ARTERIAL INTERSECTIONS AND NO CURB EXTENSION ON THE LOCAL ROAD DEPARTURE SIDE.
3. HYDRANTS SHOULD GENERALLY BE LOCATED WITHIN CURB EXTENSIONS. CURB EXTENSIONS MAY REQUIRE LENGTHENING TO RESTRICT PARKING WITHIN 5m OF HYDRANT.

3			All Dimensions Shown In Metres, Unless Otherwise Noted	
2	APRIL 2020	SCOTT NEUMAN		
1	JANUARY 2016	JAIME BOAN	Title	TRAFFIC CALMING, CURB EXTENSIONS AND ON-STREET PARKING BAY
	Revision Date	Approved	Approved By :	
		SUPPLEMENTARY STANDARD DRAWINGS		DRAWING NUMBER SSD-R.28.3
		APRIL 2020	G.M. Engineering	



NOTES:

1. MINIMUM 2.0m LANDSCAPE ISLAND.
2. FOR SECTION A-A, REFER TO SSD-R.29.1.
3. EXACT SPLITTER ISLANDS DIMENSION DETAILS TO BE DETERMINED BY ENGINEER AND APPROVED BY CITY. SEE R.29.2 FOR TYPICAL SECTION.

3			All Dimensions Shown In Metres, Unless Otherwise Noted
2	APRIL 2020	SCOTT NEUMAN	Title TRAFFIC CALMING, TRAFFIC CIRCLE
1	JANUARY 2016	JAIME BOAN	
	Revision Date	Approved	
			Approved By :  APRIL 2020 G.M. Engineering
SUPPLEMENTARY STANDARD DRAWINGS			DRAWING NUMBER SSD-R.29

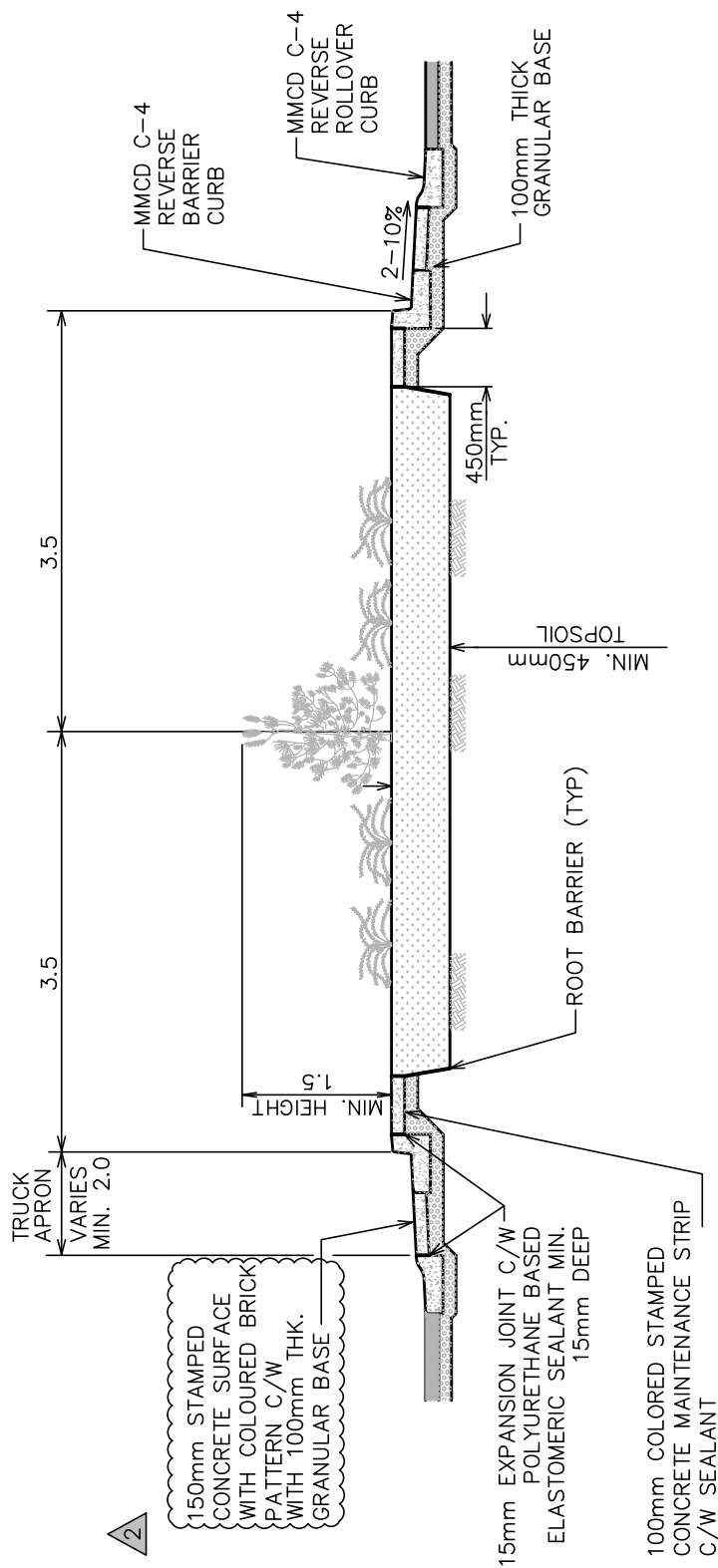

SECTION A-A

NOTES: (1) TRAFFIC CONTROL ISLAND LANDSCAPING TO BE DESIGNED BY CITY OF SURREY-PARKS, RECREATION AND CULTURE.

3			All Dimensions Shown In Metres, Unless Otherwise Noted
2	APRIL 2020	SCOTT NEUMAN	
1	JANUARY 2016	JAIME BOAN	Title TRAFFIC CONTROL, CENTRE ISLAND DETAIL
	Revision Date	Approved	
			Approved By :
SUPPLEMENTARY STANDARD DRAWINGS			DRAWING NUMBER SSD-R.29.1
			APRIL 2020 G.M. Engineering

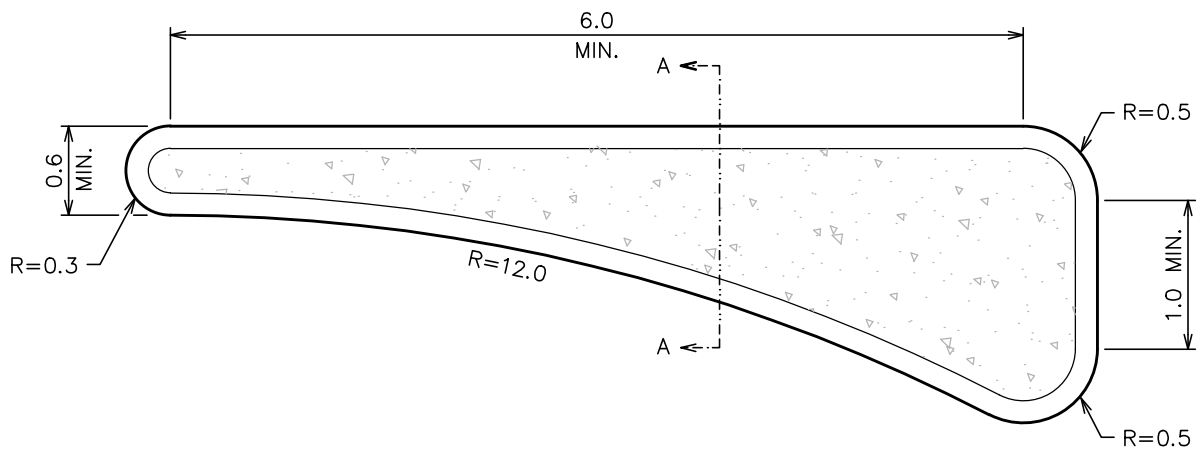

**TYPICAL ROUNDABOUT
SPLITTER**

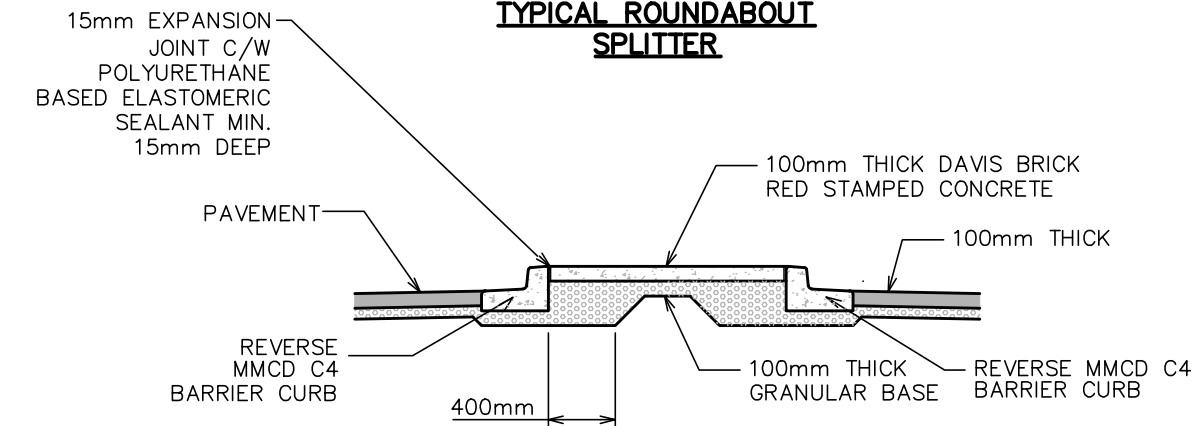

CROSS SECTION A-A

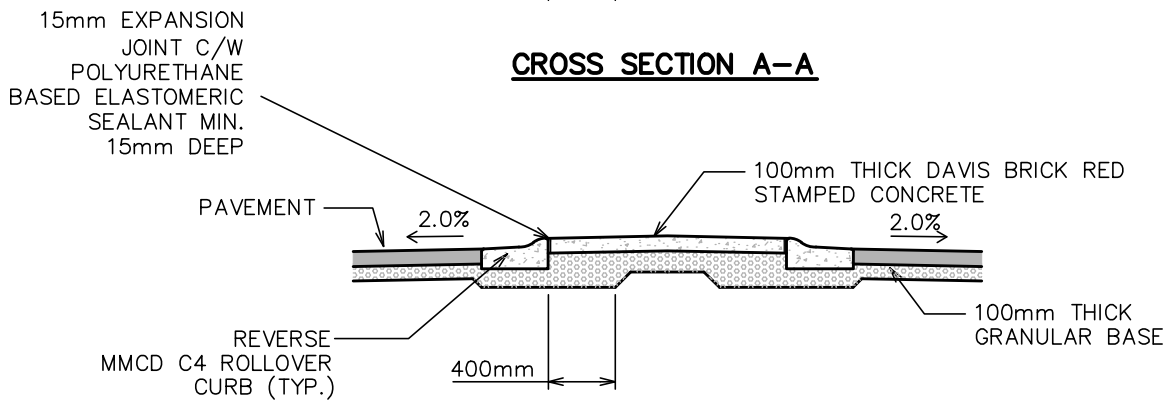

**ALTERNATE
MOUNTABLE SPLITTER ISLAND**

3			All Dimensions Shown In Metres, Unless Otherwise Noted
2	APRIL 2020	SCOTT NEUMAN	
1	JANUARY 2016	JAIME BOAN	
	Revision Date	Approved	Title TRAFFIC CONTROL, SPLITTER ISLAND DETAILS
			Approved By :
SUPPLEMENTARY STANDARD DRAWINGS			DRAWING NUMBER SSD-R.29.2
			APRIL 2020 G.M. Engineering

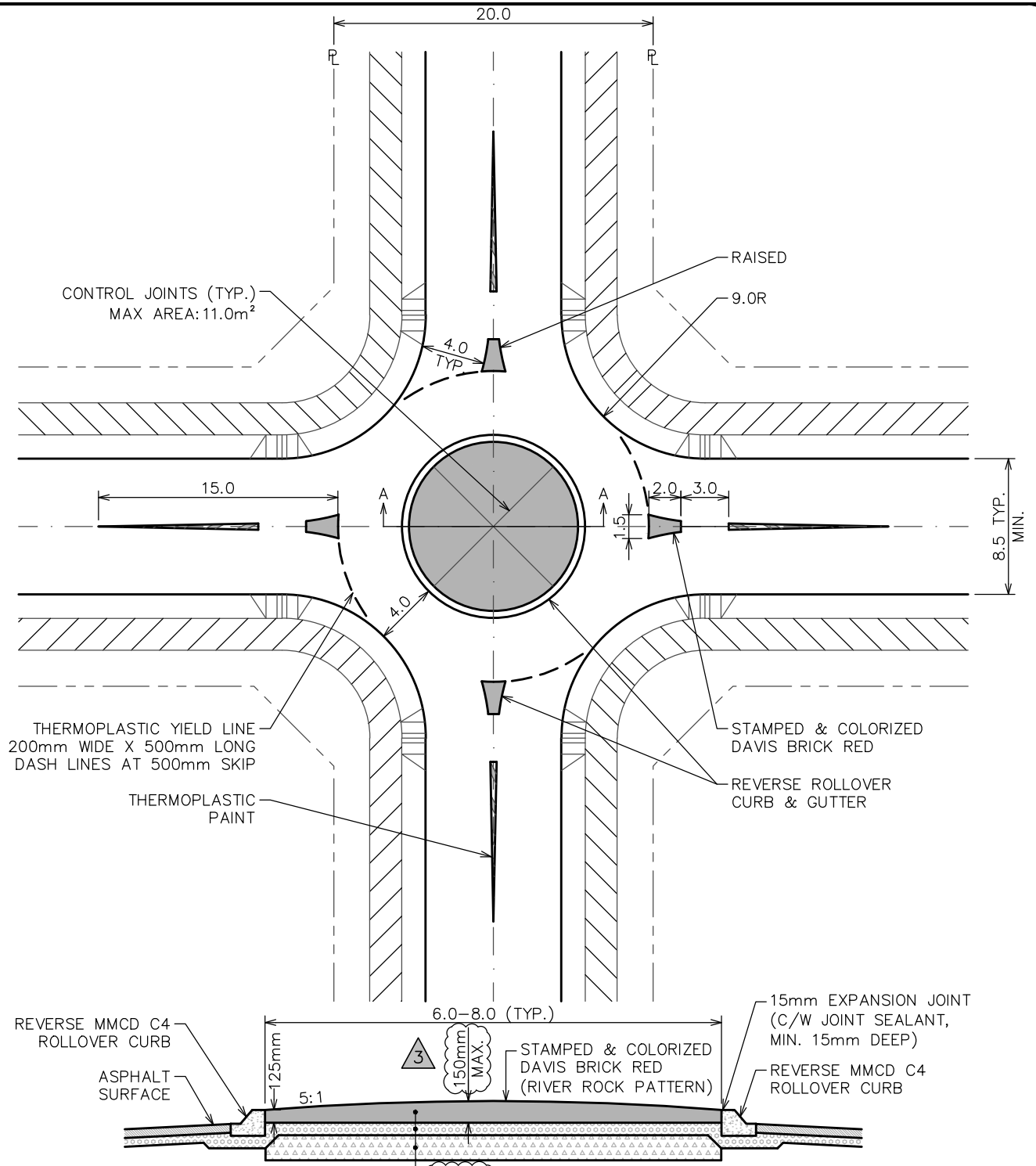

NOTES:

1. EXACT SPLITTER ISLAND DIMENSIONS
DETAILS TO BE DETERMINED BY
ENGINEER AND APPROVED BY CITY.
SEE R.29.2 FOR TYPICAL SECTION

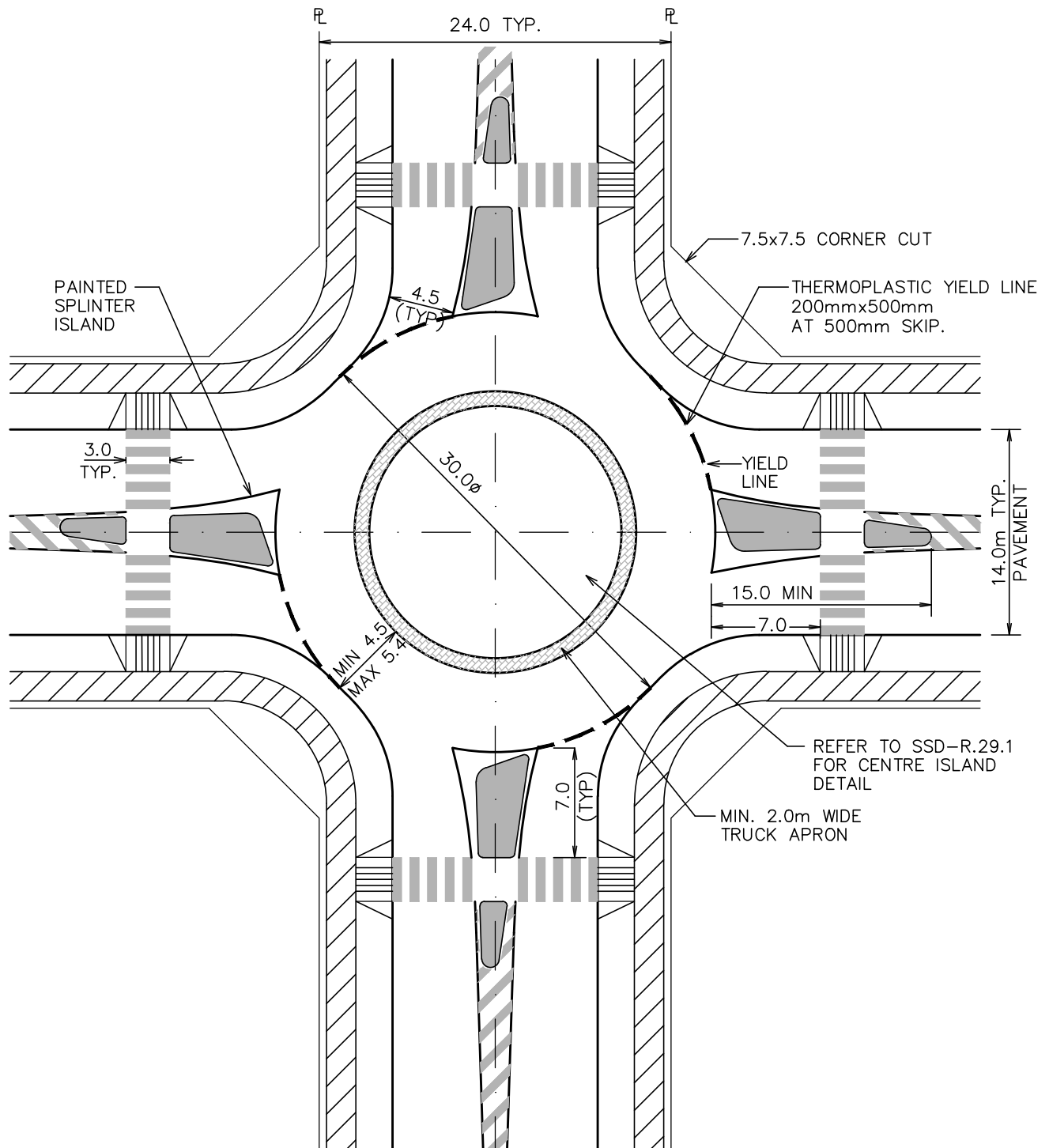

SECTION A-A

3	APRIL 2020	SCOTT NEUMAN	All Dimensions Shown In Metres, Unless Otherwise Noted
	JANUARY 2016	JAIME BOAN	
	JANUARY 2004	KOK KUEN LI	
	Revision Date	Approved	Title TRAFFIC CONTROL, TRAFFIC BUTTON
		SUPPLEMENTARY STANDARD DRAWINGS	Approved By : APRIL 2020 G.M. Engineering
			DRAWING NUMBER SSD-R.30





NOTES:

1. LANE WIDTH'S TO BE DESIGNED VERIFIED BY CITY OF SURREY.
2. YIELD LINE MARKING TO BE IN THERMOPLASTIC.
3. EXACT SPLITTER ISLANDS DIMENSION DETAILS TO BE DETERMINED BY ENGINEER AND APPROVED BY CITY SEE R.29.2 FOR TYPICAL.

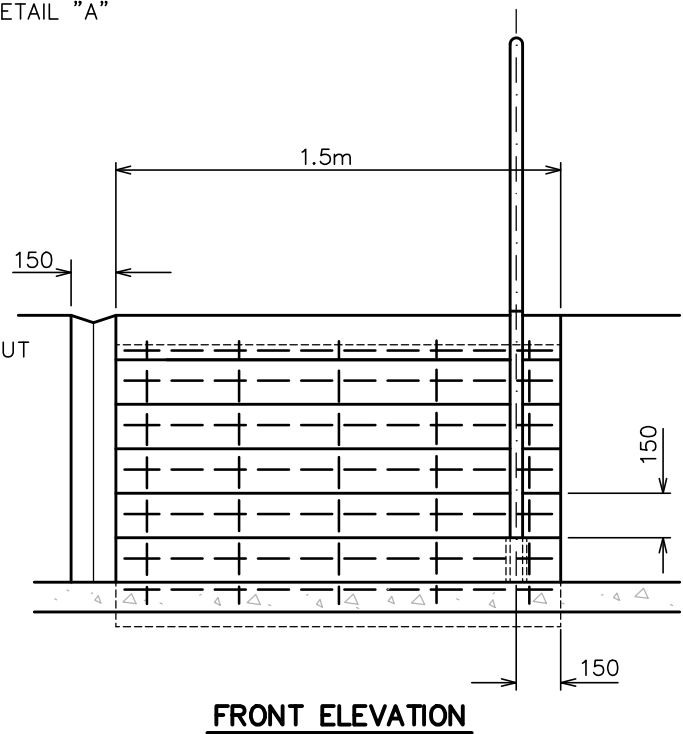
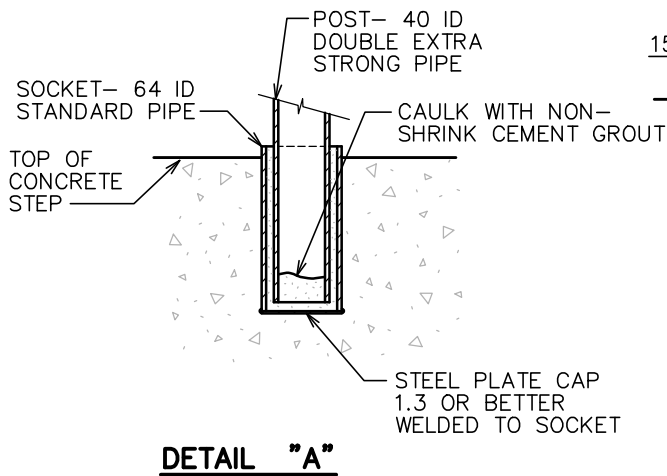
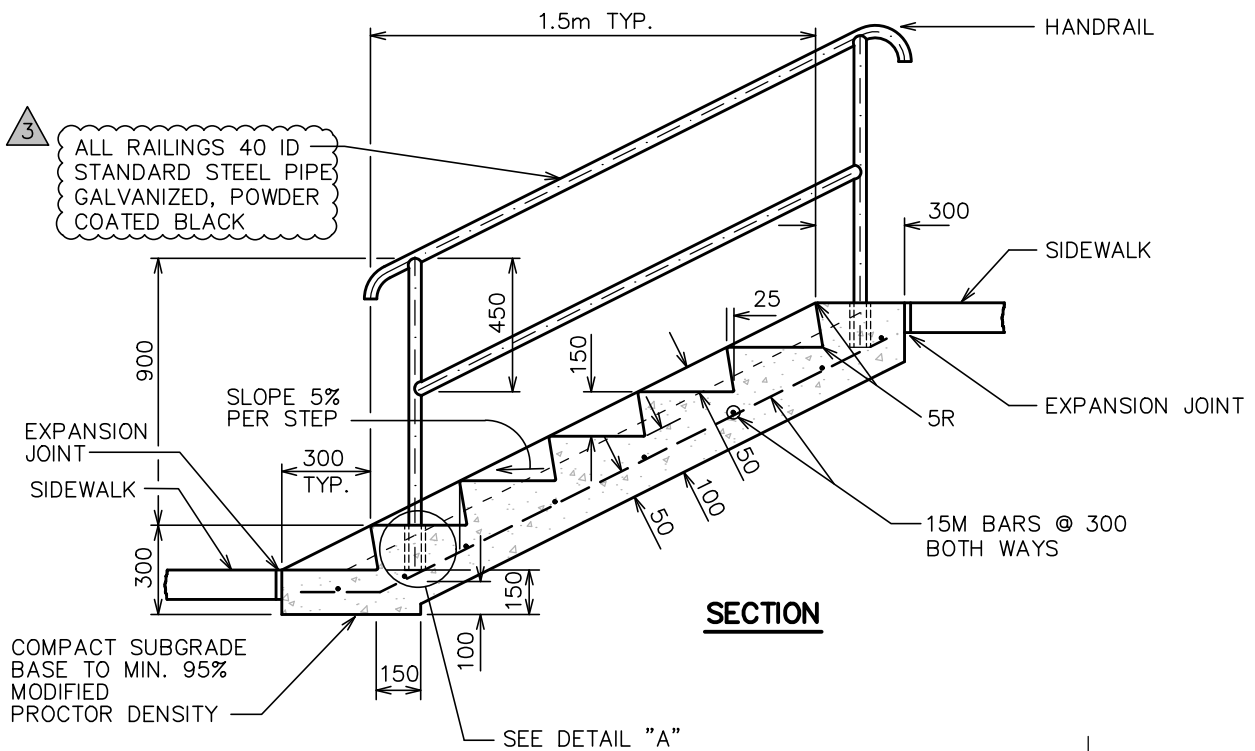
3	APRIL 2020	SCOTT NEUMAN	All Dimensions Shown In Metres, Unless Otherwise Noted
2	JANUARY 2016	JAIME BOAN	
1	JANUARY 2004	KOK KUEN LI	
	Revision Date	Approved	Title TRAFFIC CONTROL, ROUNDBOUT
 <p>SUPPLEMENTARY STANDARD DRAWINGS</p>			Approved By :  APRIL 2020 G.M. Engineering
			DRAWING NUMBER SSD-R.31



NOTE: (1) LARGER STAIRS TO BE DESIGNED BY AN ENGINEER.

3	APRIL 2020	SCOTT NEUMAN	All Dimensions Shown In Millimetres, Unless Otherwise Noted
2	JANUARY 2016	JAIME BOAN	
1	February 2002		
	Revision Date	Approved	Title CONCRETE STEPS WITHOUT FOOTING - WITH BICYCLE RAMP
 <p>CITY OF SURREY the future lives here.</p>			SUPPLEMENTARY STANDARD DRAWINGS
Approved By : 			DRAWING NUMBER
APRIL 2020			SSD-R.32
G.M. Engineering			

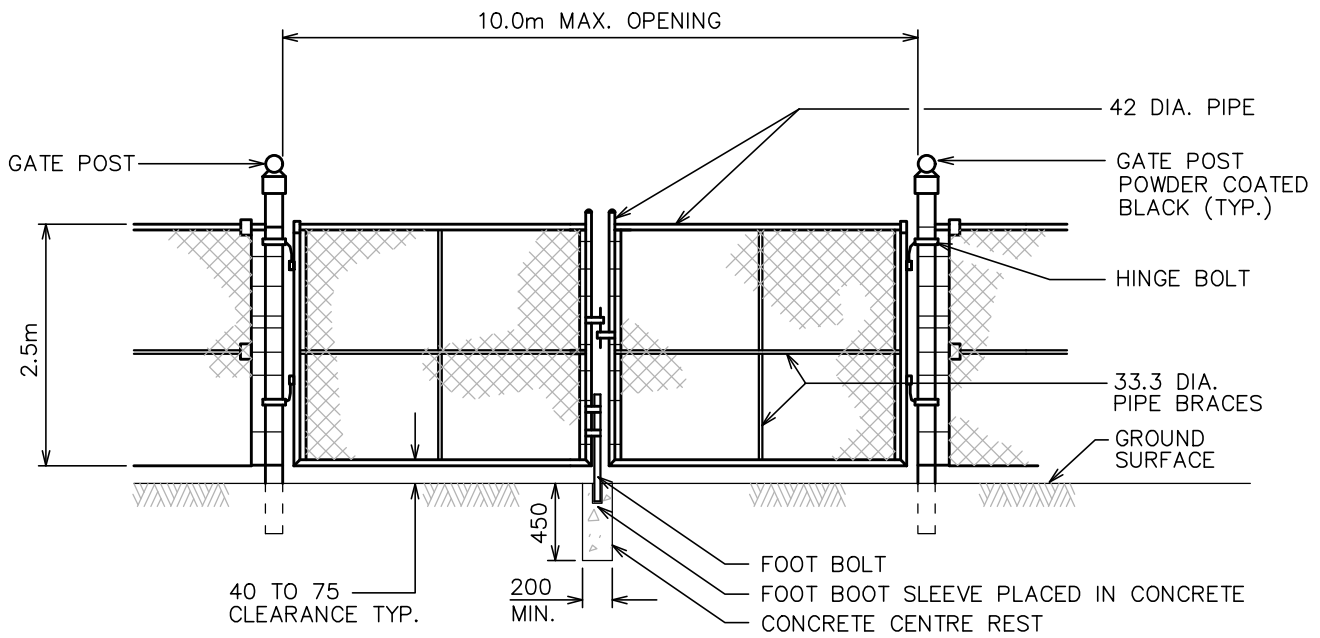

SECURITY DOUBLE GATE

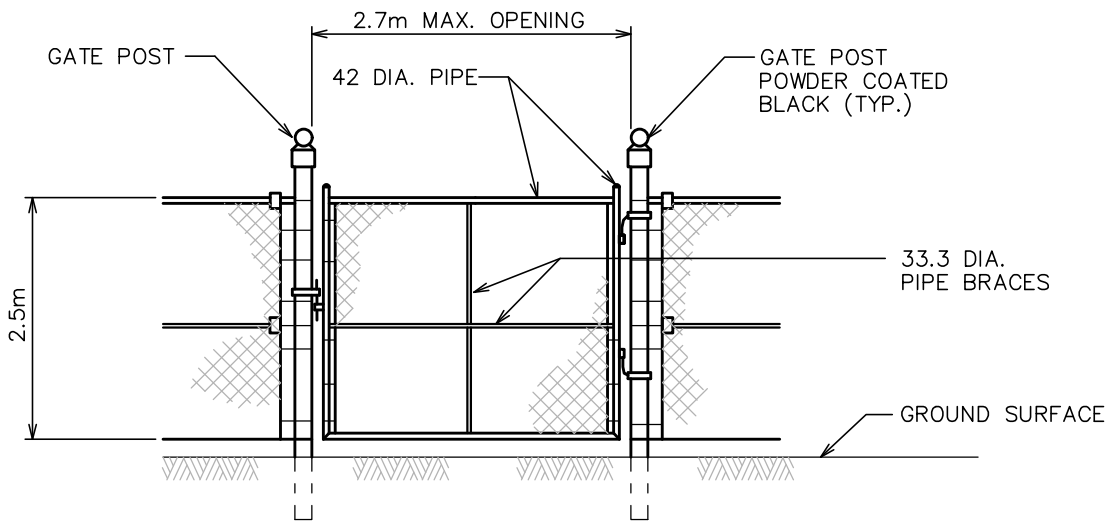

SECURITY SINGLE GATE

NOTES:

1. GATE PANELS UP TO 1.8m WIDE REQUIRE HORIZONTAL BRACE ONLY.
2. GATE PANELS OVER 1.8m WIDE REQUIRE HORIZONTAL AND VERTICAL BRACES.
3. CHAIN LINK FENCE FABRIC: 6ga. 50mm BLACK VINYL COVERED WIRE MESH

3			All Dimensions Shown In Millimetres, Unless Otherwise Noted
2	APRIL 2020	SCOTT NEUMAN	
1	JANUARY 2016	JAIME BOAN	
	Revision Date	Approved	Title SECURITY CHAIN-LINK FENCE – GATES
			Approved By :
			SUPPLEMENTARY STANDARD DRAWINGS APRIL 2020 G.M. Engineering
			DRAWING NUMBER SSD-R.33

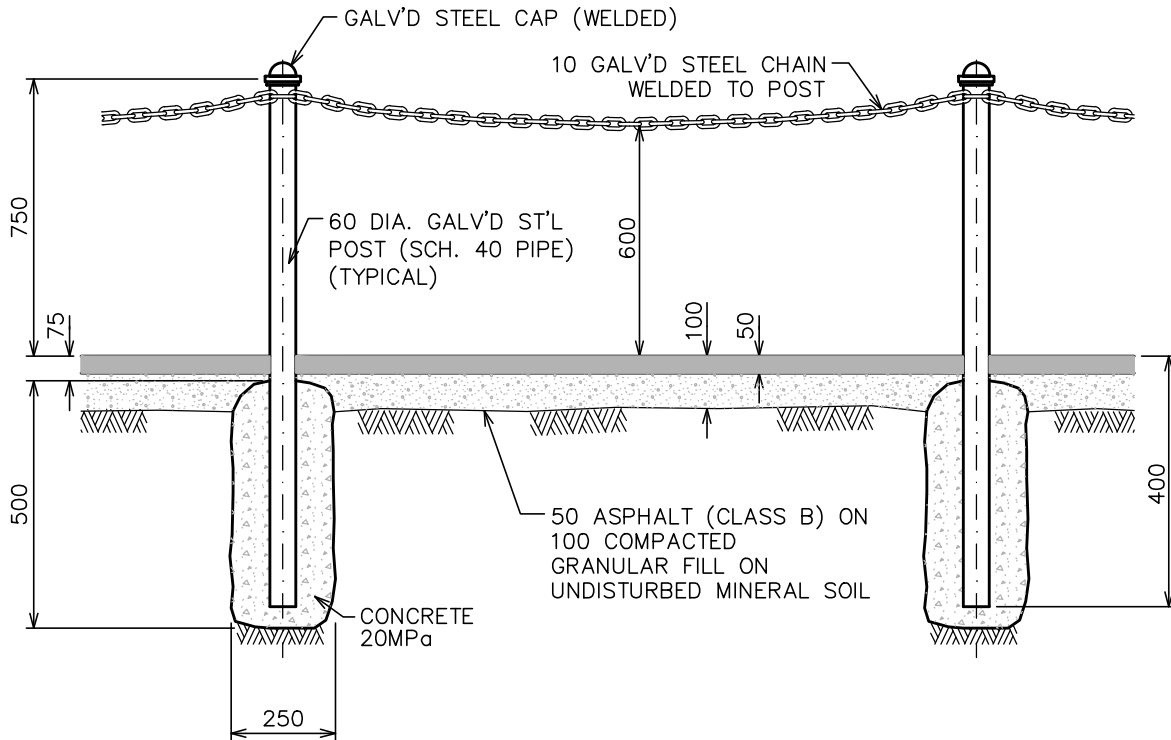
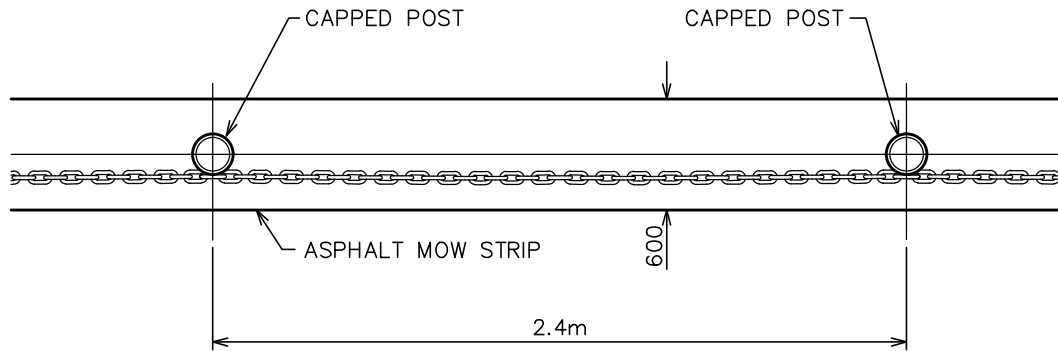

NOTES:

1. WELDS TO BE PAINTED WITH ZINC-RICH PAINT.
2. PARKING LOTS – PEDESTRIAN OPENINGS MUST BE PROVIDED EVERY 15.25m AND MUST BE 1.0m IN WIDTH.

3			All Dimensions Shown In Millimetres, Unless Otherwise Noted	
2	APRIL 2020	SCOTT NEUMAN		
1	JANUARY 2016	JAIME BOAN	Title	DECORATIVE FENCE
	Revision Date	Approved		
			Approved By :	
			APRIL 2020	
			DRAWING NUMBER	SSD-R.34

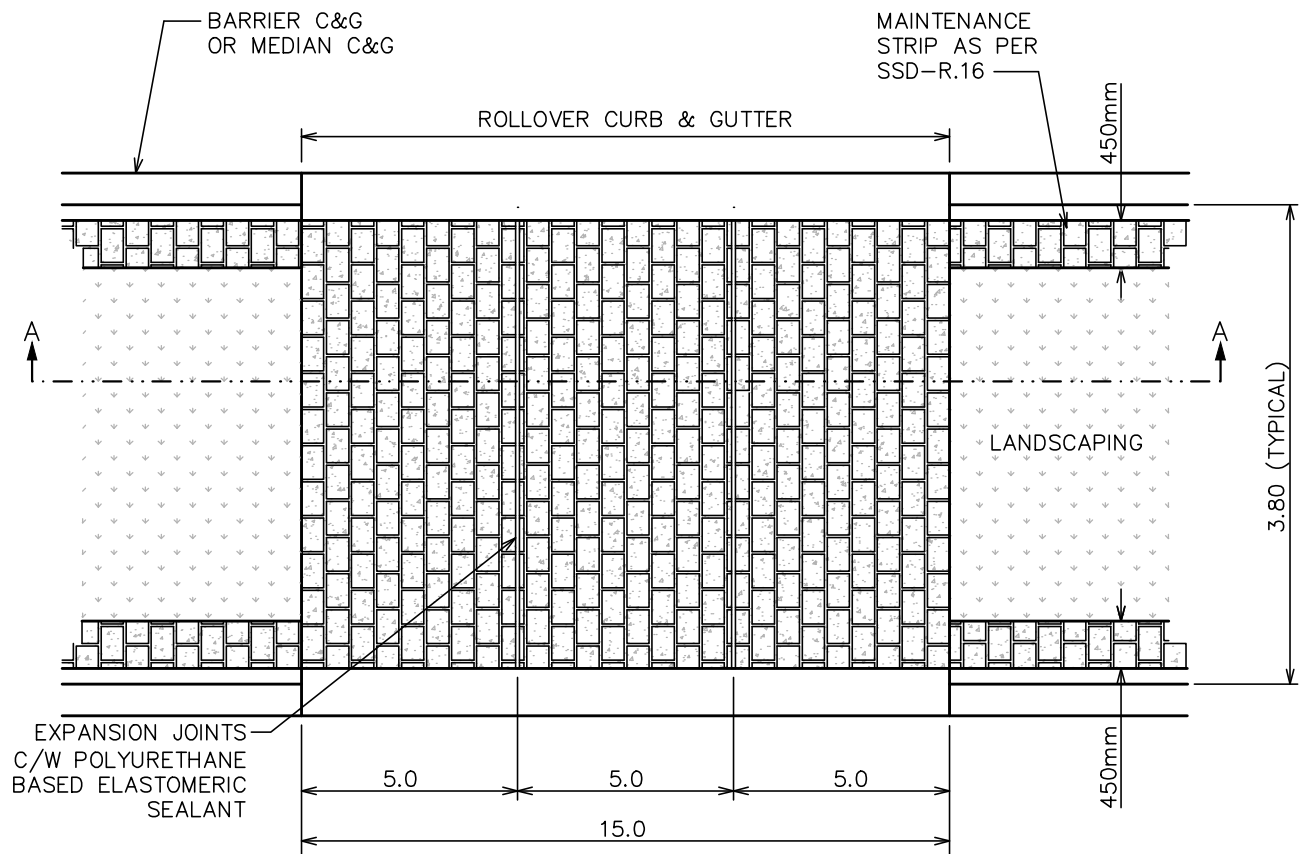

PLAN VIEW

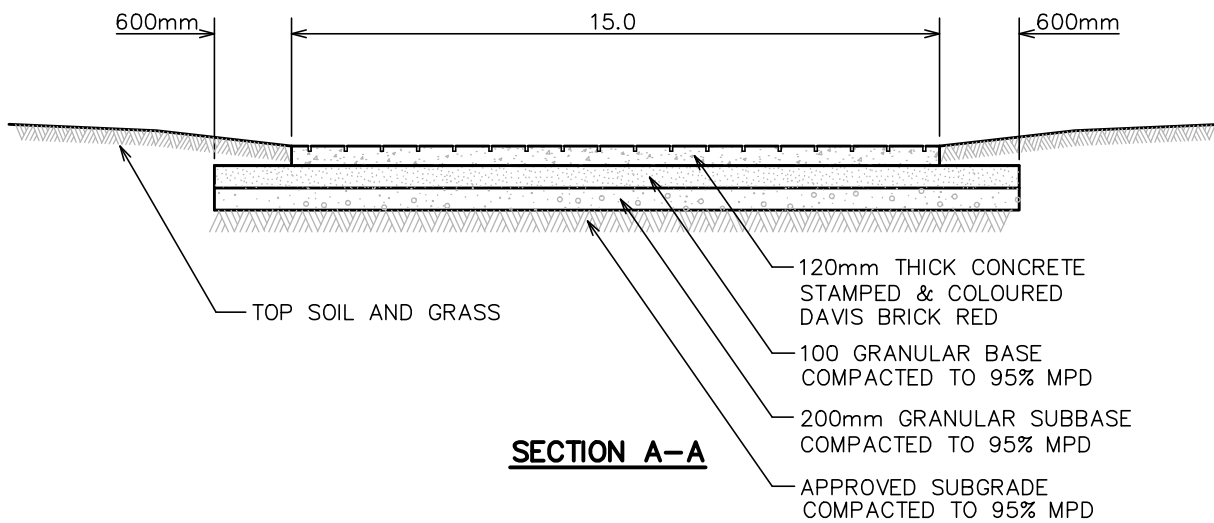

SECTION A-A

3		
2	APRIL 2020	SCOTT NEUMAN
1	JANUARY 2016	JAIME BOAN
	Revision Date	Approved

All Dimensions Shown In Metres,
Unless Otherwise Noted

Title **RAISED MEDIAN,
MAINTENANCE PAD**

SUPPLEMENTARY
STANDARD
DRAWINGS

Approved By : 
APRIL 2020 G.M. Engineering

DRAWING NUMBER
SSD-R.35

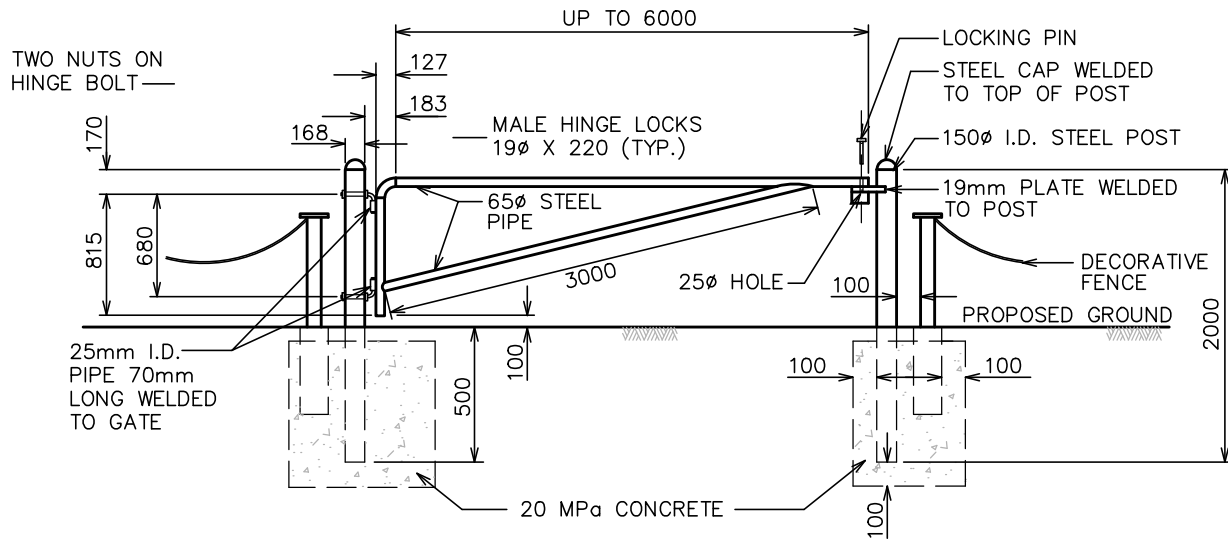

GATE DETAILS

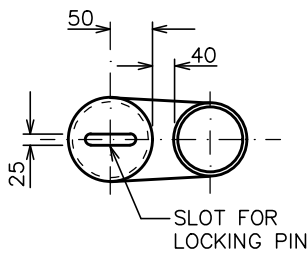

SECTION B-B

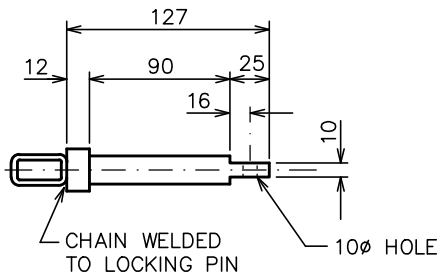
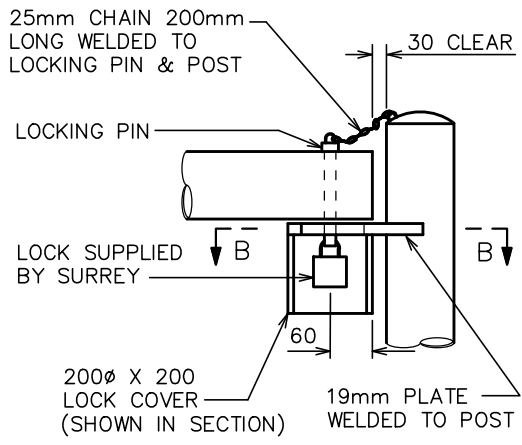

SIDE VIEW

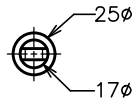

END VIEW

GATE LOCKING PIN DETAIL

NOTES:

1. ALL GATE COMPONENTS TO HAVE PRIME COAT AND TWO COATS OF WHITE ENAMEL PAINT.
2. ALL STEEL TO BE A MINIMUM OF A36 GRADE.

3			All Dimensions Shown In Millimetres, Unless Otherwise Noted
2	APRIL 2020	SCOTT NEUMAN	
1	JANUARY 2016	JAIME BOAN	
	Revision Date	Approved	SWING GATE DETAILS
			Approved By :
			APRIL 2020
SUPPLEMENTARY STANDARD DRAWINGS			DRAWING NUMBER SSD-R.36

BASE TYPE SHALL BE IMPRINTED IN CONCRETE WITH A 25mm HIGH LETTER. LOCATE IMPRINT SO IT IS VISIBLE AFTER POLE INSTALLATION.

305 (ANCHOR BOLT CIRCLE)

CONCRETE SHALL HAVE ATTAINED A COMPRESSIVE STRENGTH OF 30MPa PRIOR TO POLE INSTALLATION.

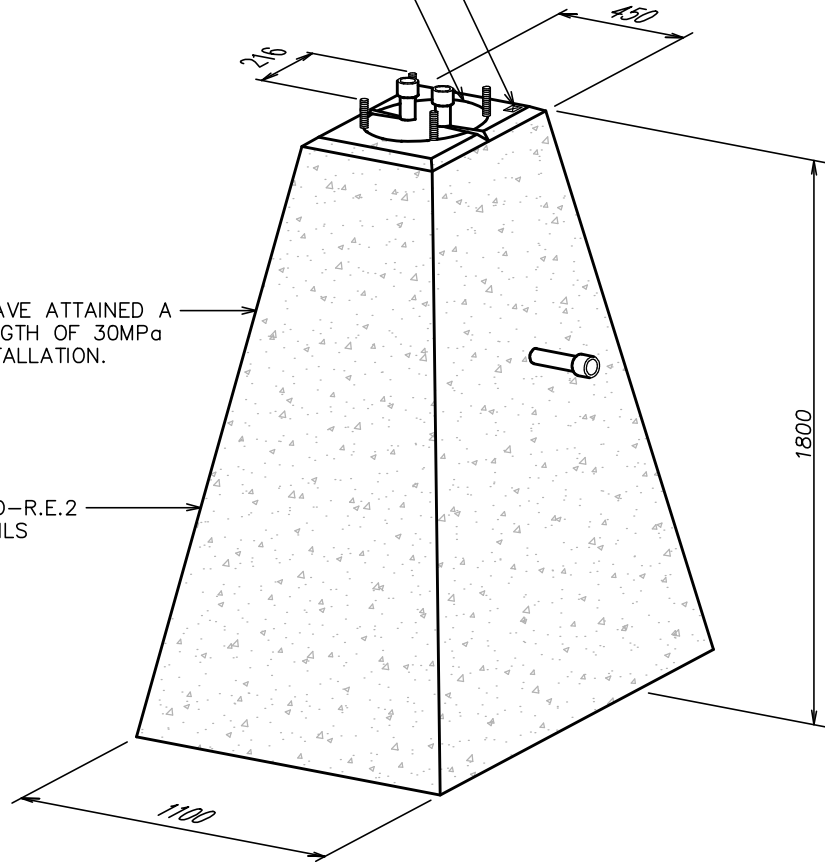

SEE DRAWING SSD-R.E.2 FOR REBAR DETAILS

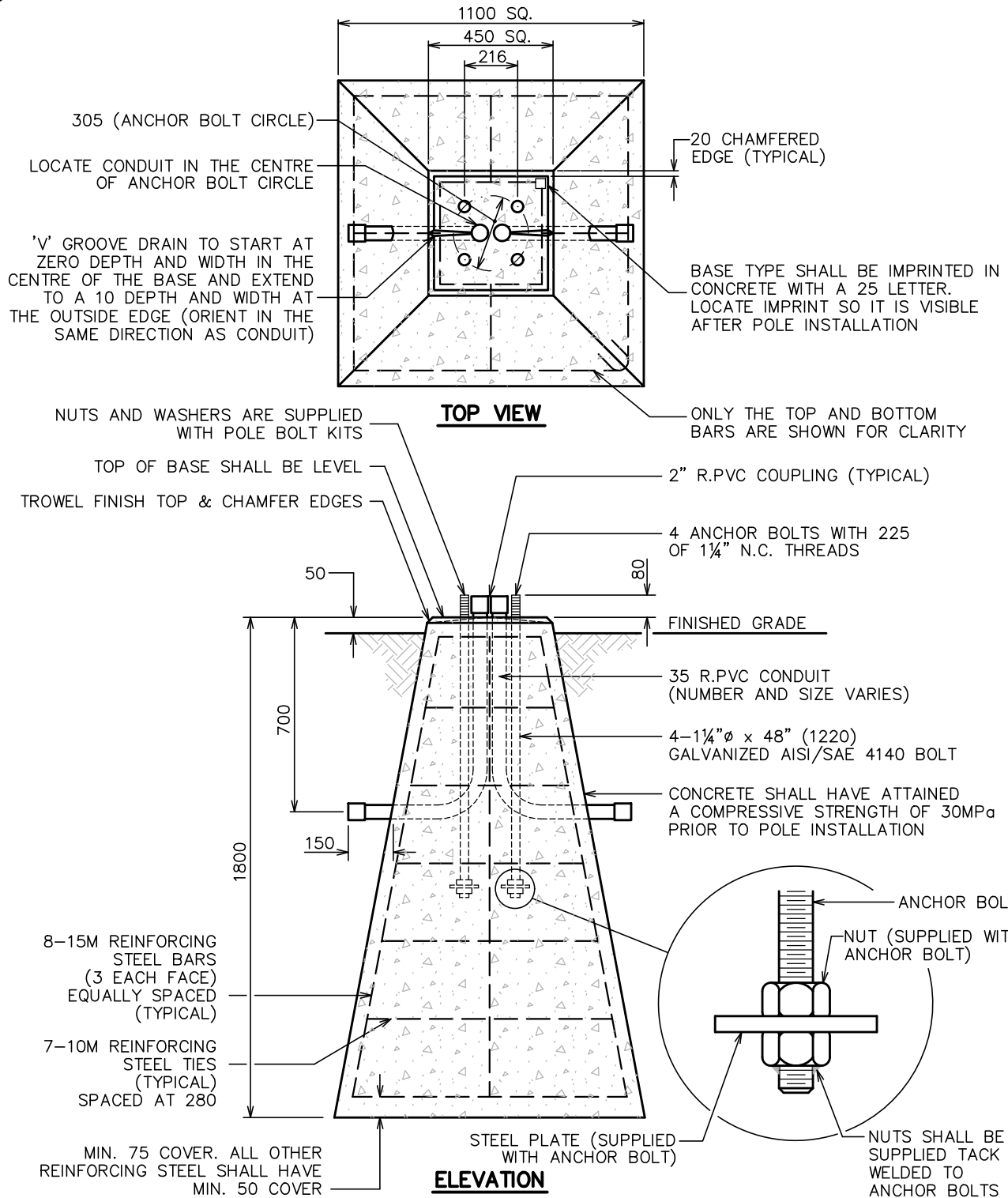

PRECAST CONCRETE BASES

3			All Dimensions Shown In Millimetres, Unless Otherwise Noted
2	APRIL 2020	SCOTT NEUMAN	
1	JANUARY 2016	JAMIE BOAN	
	Revision Date	Approved	Title TYPE D2 CONCRETE BASE FOR 13.5m DAVIT POLE PRECAST
			Approved By :  APRIL 2020 G.M. Engineering
SUPPLEMENTARY STANDARD DRAWINGS			DRAWING NUMBER SSD-R.E.1



3			All Dimensions Shown In Millimetres, Unless Otherwise Noted
2	APRIL 2020	SCOTT NEUMAN	
1	JANUARY 2016	JAMIE BOAN	Title PRECAST TYPE D2 CONCRETE BASE FOR 13.5m DAVIT POLE
	Revision Date	Approved	
 CITY OF SURREY the future lives here.			Approved By :  APRIL 2020 G.M. Engineering
SUPPLEMENTARY STANDARD DRAWINGS			DRAWING NUMBER SSD-R.E.2

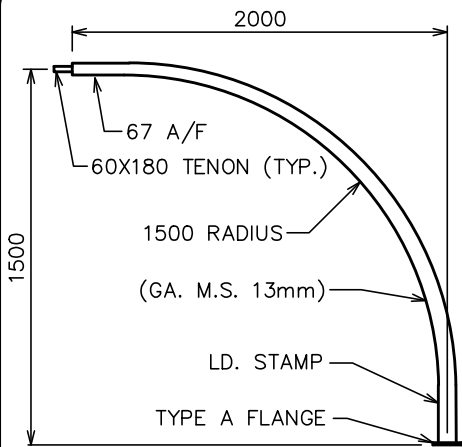

SPECIAL TYPE 2A ARM

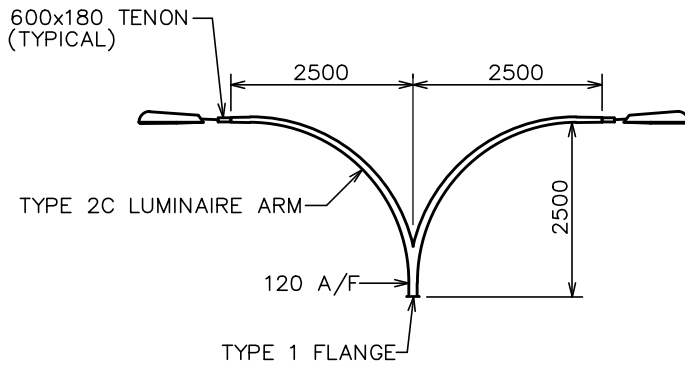
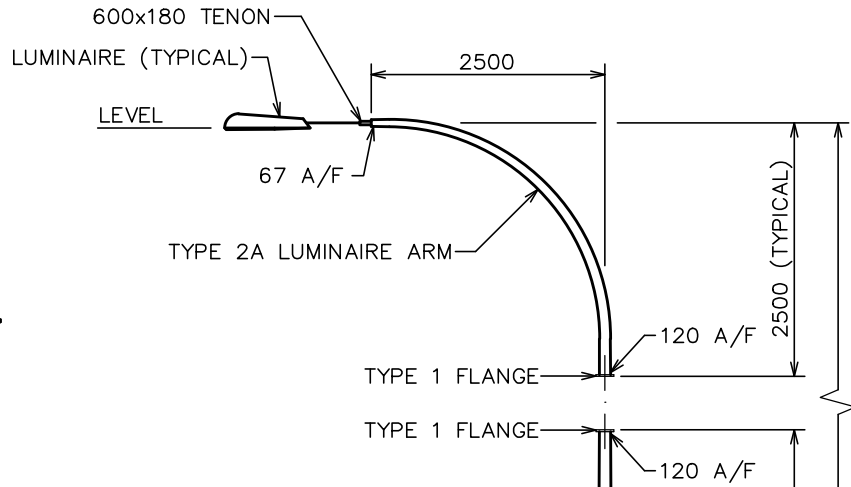

TYPE 2 (11.0m) SHAFT

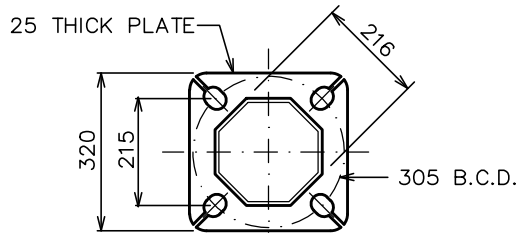

POLE BASE PLATE

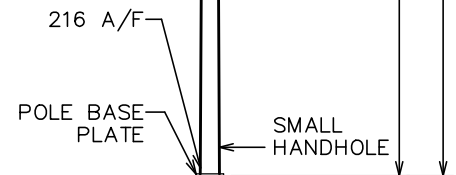

ELEVATION

3		
2	APRIL 2020	SCOTT NEUMAN
1	JANUARY 2016	JAMIE BOAN
	Revision Date	Approved

All Dimensions Shown In Millimetres,
Unless Otherwise Noted

Title **TYPE 2 SHAFT INSTALLATION DETAILS
FOR 13.5m DAVIT POLE**



SUPPLEMENTARY
STANDARD
DRAWINGS

Approved By :

APRIL 2020

G.M. Engineering

DRAWING NUMBER

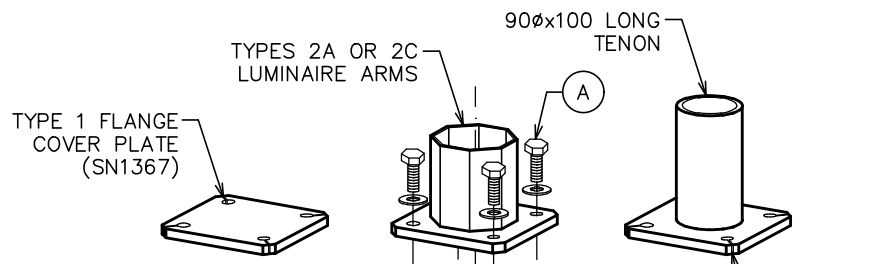

SSD-R.E.3



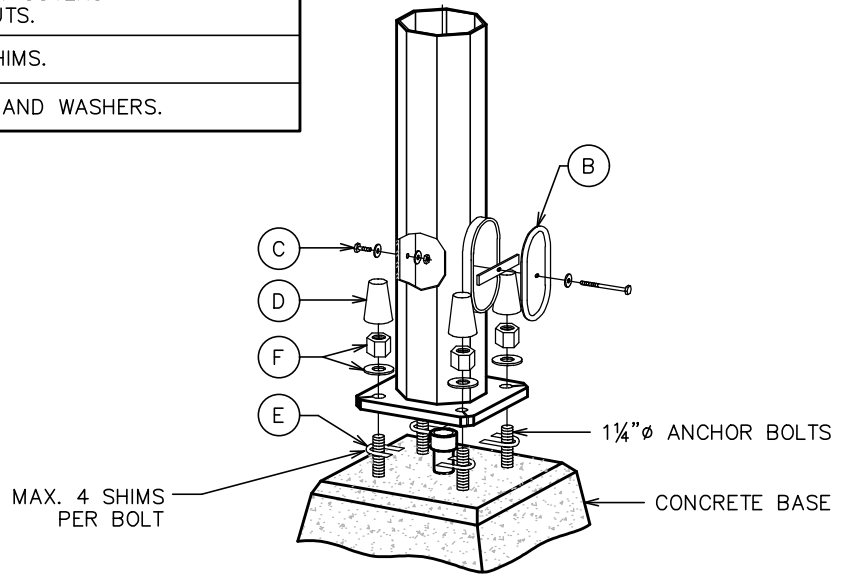
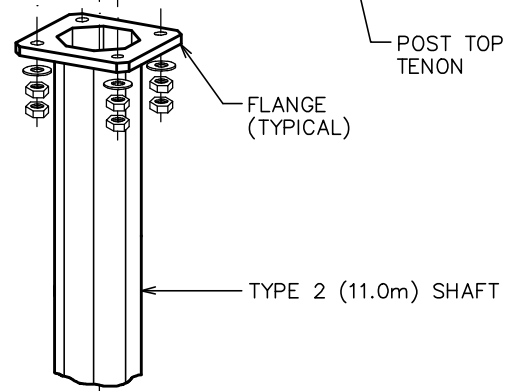

TYPE 2 (11.0m) SHAFT BOLT KIT		
ITEM	QUANTITY	DESCRIPTION
A	4	5/8"Ø x 3" LONG BOLT, 2 NUTS AND 2 WASHERS.
B	1	SMALL HANDHOLE COVER WITH 3/8"Ø x 3 1/2" LONG BOLT, WASHER & BACKER BAR.
C	1	3/8"Ø x 1 1/4" LONG BONDING BOLT WITH 1 NUT AND 2 WASHERS.
D	4	PLASTIC NUT COVERS FOR 1 1/4" NUTS.
E	4	LEVELING SHIMS.
F	4	1 1/4"Ø NUTS AND WASHERS.

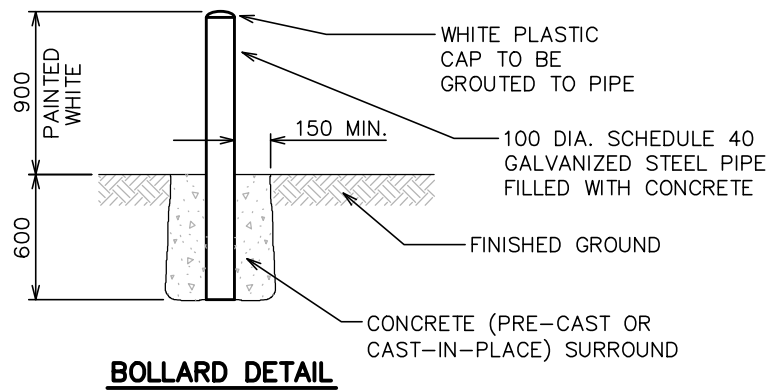
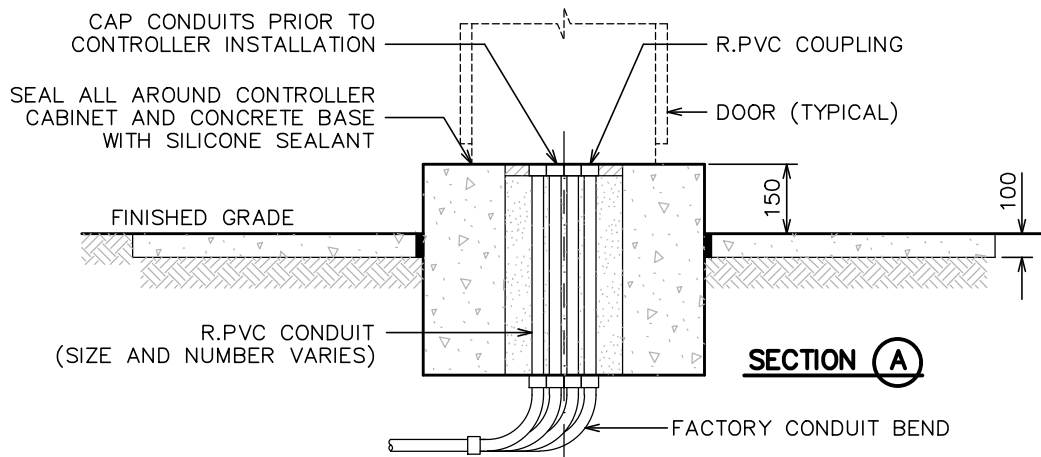
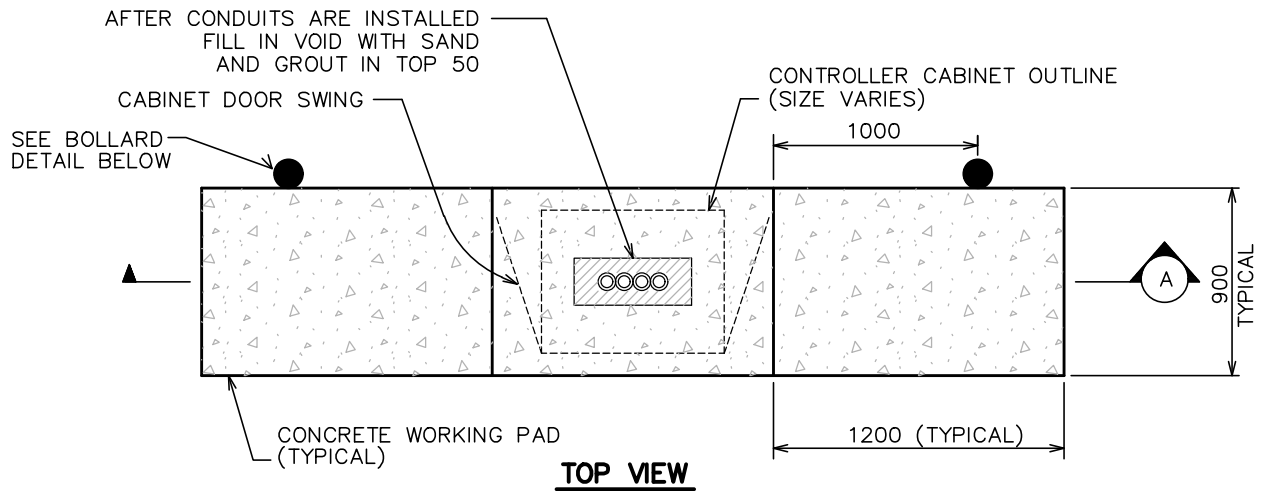

POLE ASSEMBLY DETAIL

3			All Dimensions Shown In Millimetres, Unless Otherwise Noted
2	APRIL 2020	SCOTT NEUMAN	
1	JANUARY 2016	JAMIE BOAN	Title TYPE 2 SHAFT POLE ASSEMBLY FOR 13.5m DAVIT POLE
	Revision Date	Approved	
 SUPPLEMENTARY STANDARD DRAWINGS			Approved By :  APRIL 2020 G.M. Engineering
			DRAWING NUMBER SSD-R.E.4



3			All Dimensions Shown In Millimetres, Unless Otherwise Noted
2	APRIL 2020	SCOTT NEUMAN	
1	JANUARY 2016	JAMIE BOAN	Title MODEL 332 TRAFFIC SIGNAL CABINET INSTALLATION
	Revision Date	Approved	
 <p>CITY OF SURREY the future lives here.</p>			Approved By :  APRIL 2020 G.M. Engineering
SUPPLEMENTARY STANDARD DRAWINGS			DRAWING NUMBER SSD-R.E.5

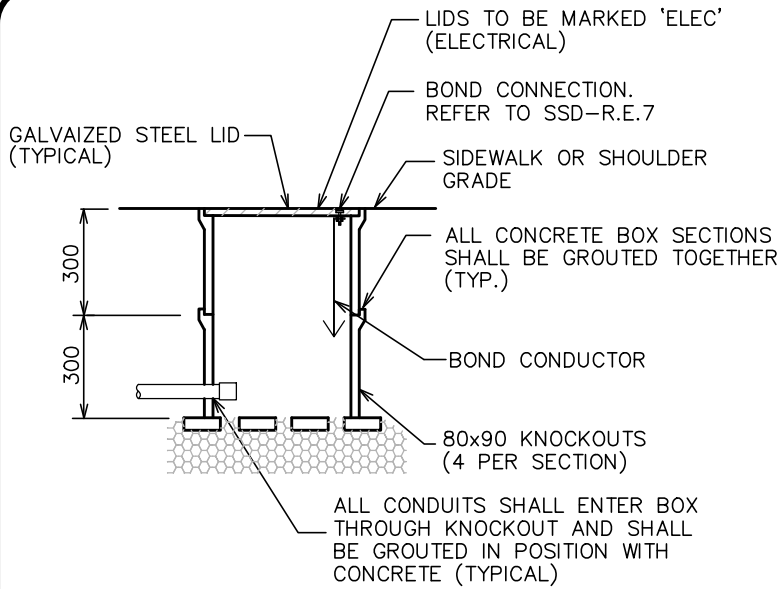

TYPE 1 J.B.
(305x510 I.D.)

CONCRETE WALL SHALL BE 150mm UNIFORM THICKNESS ALL AROUND JUNCTION BOX

CONCRETE BRICKS PLACED FLAT TO ALLOW FOR DRAINAGE, NO MORTAR REQUIRED. (TYPICAL)

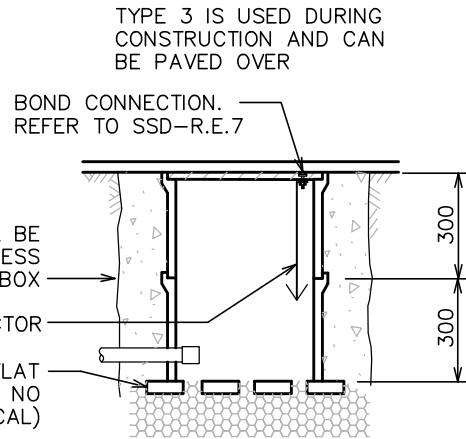

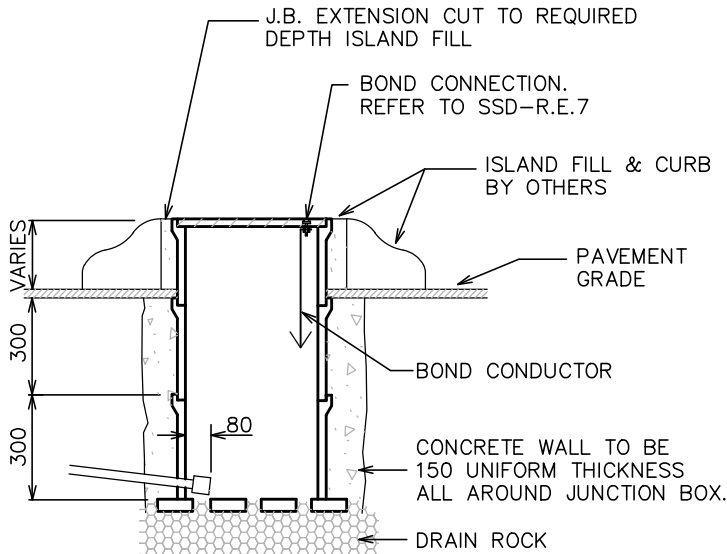

TYPE 3 J.B.
(305x510 I.D.)



TYPE 2 J.B.
(305x510 I.D.)

NOTE: (1) TYPES 1, 2, AND 3 JUNCTION BOXES SHALL BE NO.37 (OR APPROVED EQUAL).

3		All Dimensions Shown In Millimetres, Unless Otherwise Noted
2	APRIL 2020 SCOTT NEUMAN	
1	JANUARY 2016 JAMIE BOAN	
	Revision Date Approved	Title TYPE 1, 2, AND 3 JUNCTION BOX DETAILS CONCRETE
 SUPPLEMENTARY STANDARD DRAWINGS		Approved By :  APRIL 2020 G.M. Engineering
		DRAWING NUMBER SSD-R.E.6

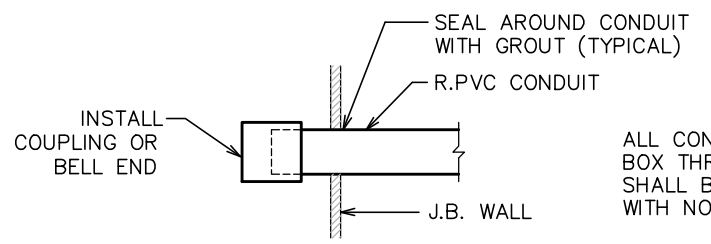
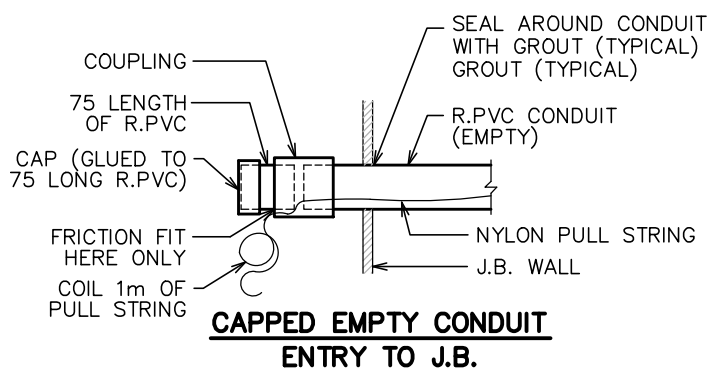

NOTE: ALL CONDUITS TO DRAIN TO J.B.

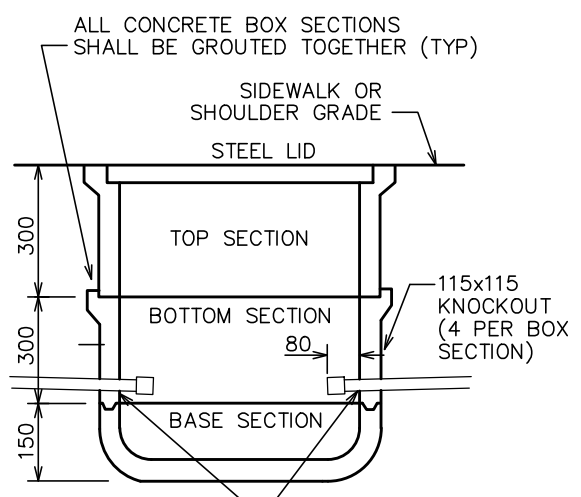

ALL CONDUITS SHALL ENTER BOX THROUGH KNOCKOUT AND SHALL BE GROUTED IN POSITION WITH NON-SHRINK GROUT (TYP.)

NOTE: TYPE 5 J.B. SHALL BE NO.66 (OR APPROVED EQUAL)

TYPE 5 JUNCTION BOX
(430x760 I.D.)

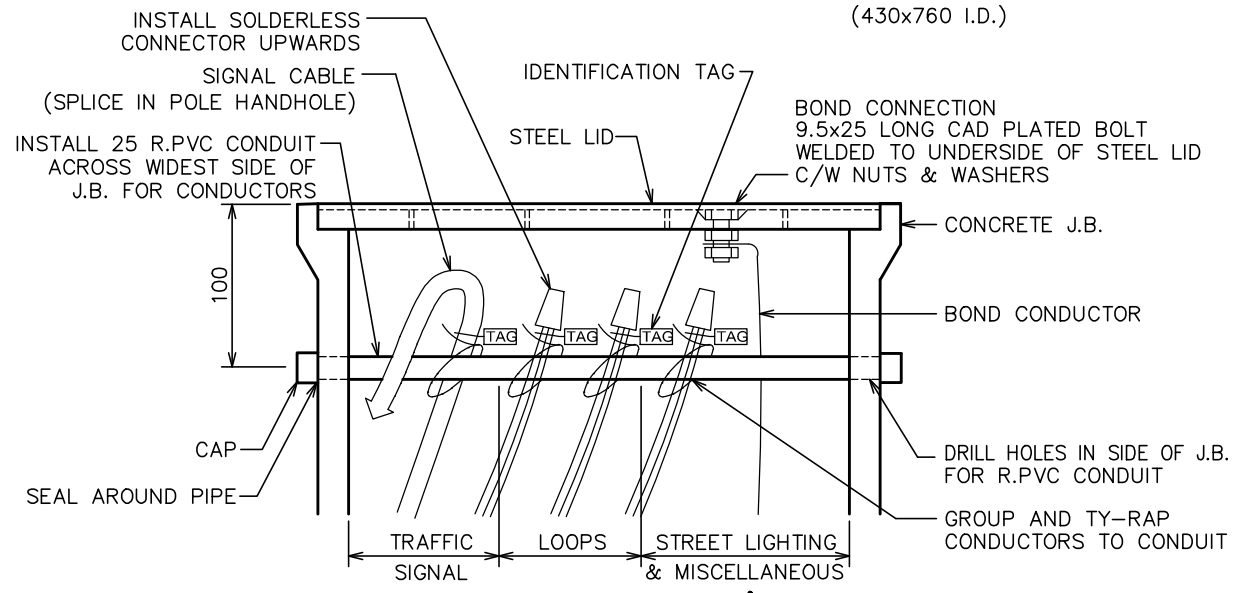

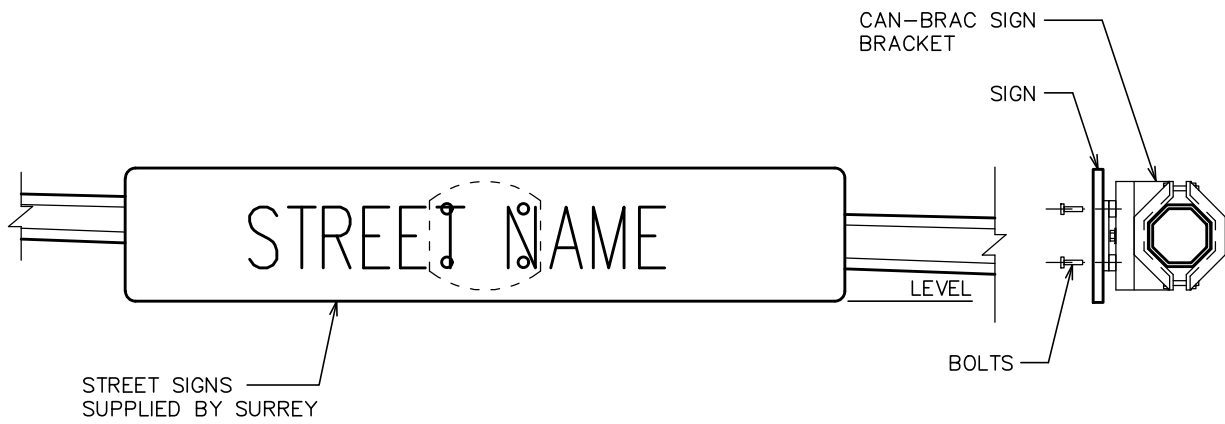

- NOTES: (1) LEAVE 1.0m OF SLACK FOR ALL CONDUCTORS IN JUNCTION BOX.
 (2) GROUP AND BUNDLE ALL CONDUCTORS SEPARATELY AS FOLLOWS:
 - DETECTORS LOOP CABLES
 - SIGNAL CABLES
 - LIGHTING AND MISCELLANEOUS CONDUCTORS
 (3) IDENTIFICATION TAGS SHALL BE NEATLY MARKED WITH A BLACK INDELIBLE PEN.
 (4) OFFSET R.PVC CONDUIT BAR 100 FROM SIDE OF JUNCTION BOX.

3			All Dimensions Shown In Millimetres, Unless Otherwise Noted
2	APRIL 2020	SCOTT NEUMAN	
1	JANUARY 2016	JAMIE BOAN	Title TYPE 5 JUNCTION BOX DETAILS (CONCRETE)
	Revision Date	Approved	
			Approved By : APRIL 2020 G.M. Engineering
SUPPLEMENTARY STANDARD DRAWINGS			DRAWING NUMBER SSD-R.E.7



STREET NAME SIGN MOUNTING DETAIL

3			All Dimensions Shown In Millimetres, Unless Otherwise Noted
2	APRIL 2020	SCOTT NEUMAN	
1	JANUARY 2016	JAMIE BOAN	Title STREET NAME SIGN MOUNTING DETAILS
	Revision Date	Approved	
			Approved By :  APRIL 2020 G.M. Engineering
SUPPLEMENTARY STANDARD DRAWINGS			DRAWING NUMBER SSD-R.E.8

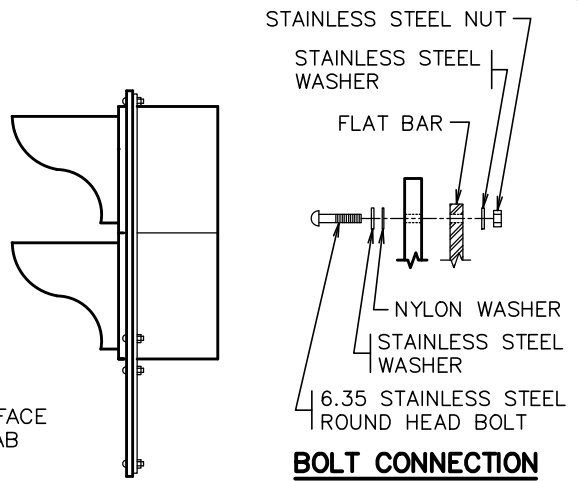
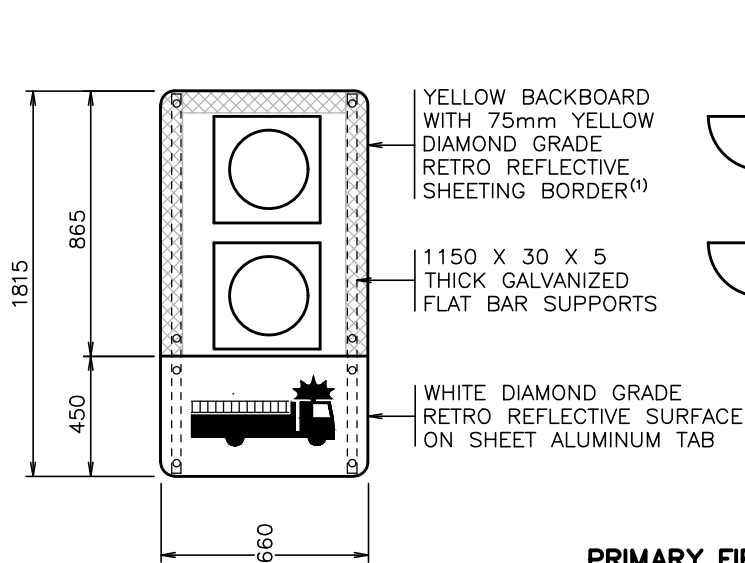

**BOLT CONNECTION
DETAIL**

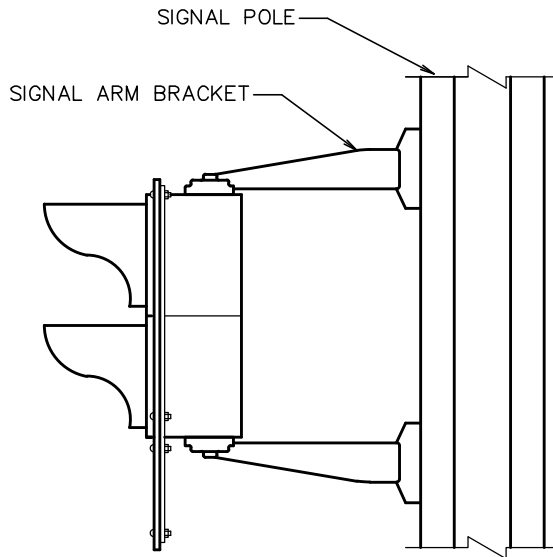
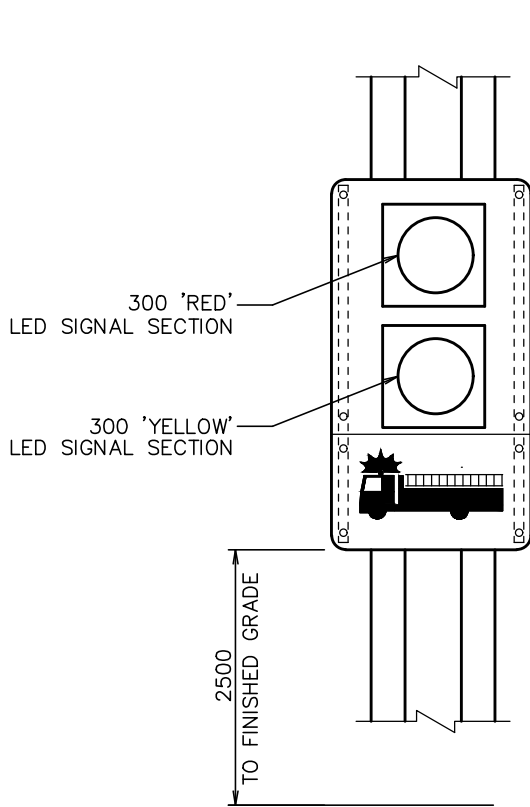

PRIMARY FIRE SIGNAL HEAD MOUNTING

SUPPLEMENTARY TAB SIGN
(ID-22SR OR ID-22SL) AS PER MUTCD





SECONDARY FIRE SIGNAL HEAD MOUNTING

NOTE: (1) SCOTCH LITE DIAMOND GRADE VIP REFLECTIVE, SERIES 3990

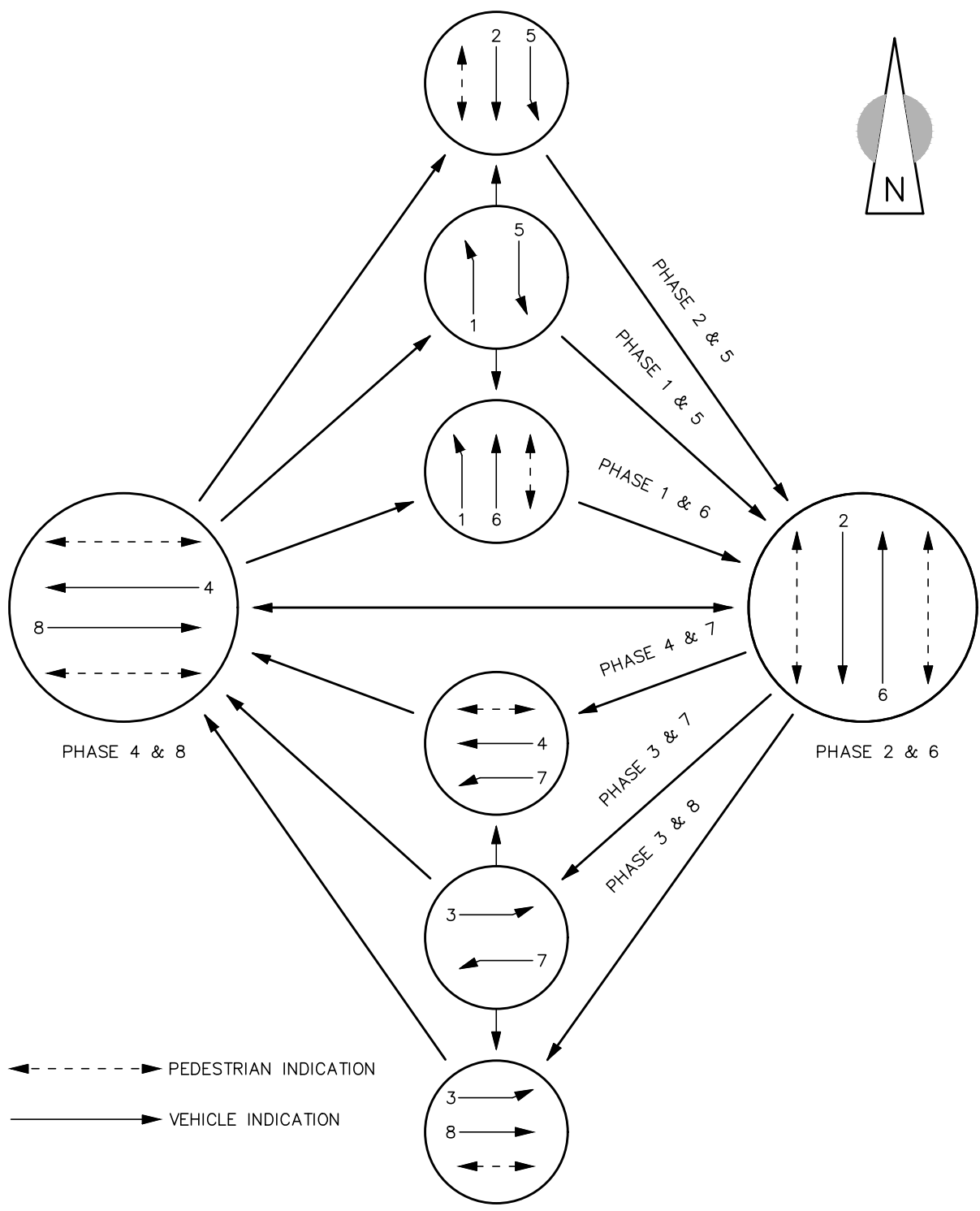
3			All Dimensions Shown In Millimetres, Unless Otherwise Noted
2	APRIL 2020	SCOTT NEUMAN	
1	JANUARY 2016	JAMIE BOAN	Title
	Revision Date	Approved	FIRE SIGNAL SIGNS
		SUPPLEMENTARY STANDARD DRAWINGS	Approved By : 
		APRIL 2020	G.M. Engineering
			DRAWING NUMBER SSD-R.E.9



3			All Dimensions Shown In Millimetres, Unless Otherwise Noted
2	APRIL 2020	SCOTT NEUMAN	
1	JANUARY 2016	JAMIE BOAN	Title PHASING DIAGRAM FOR 8-PHASE CONTROLLER
	Revision Date	Approved	
 CITY OF SURREY the future lives here.			Approved By :  APRIL 2020 G.M. Engineering
SUPPLEMENTARY STANDARD DRAWINGS			DRAWING NUMBER SSD-R.E.10

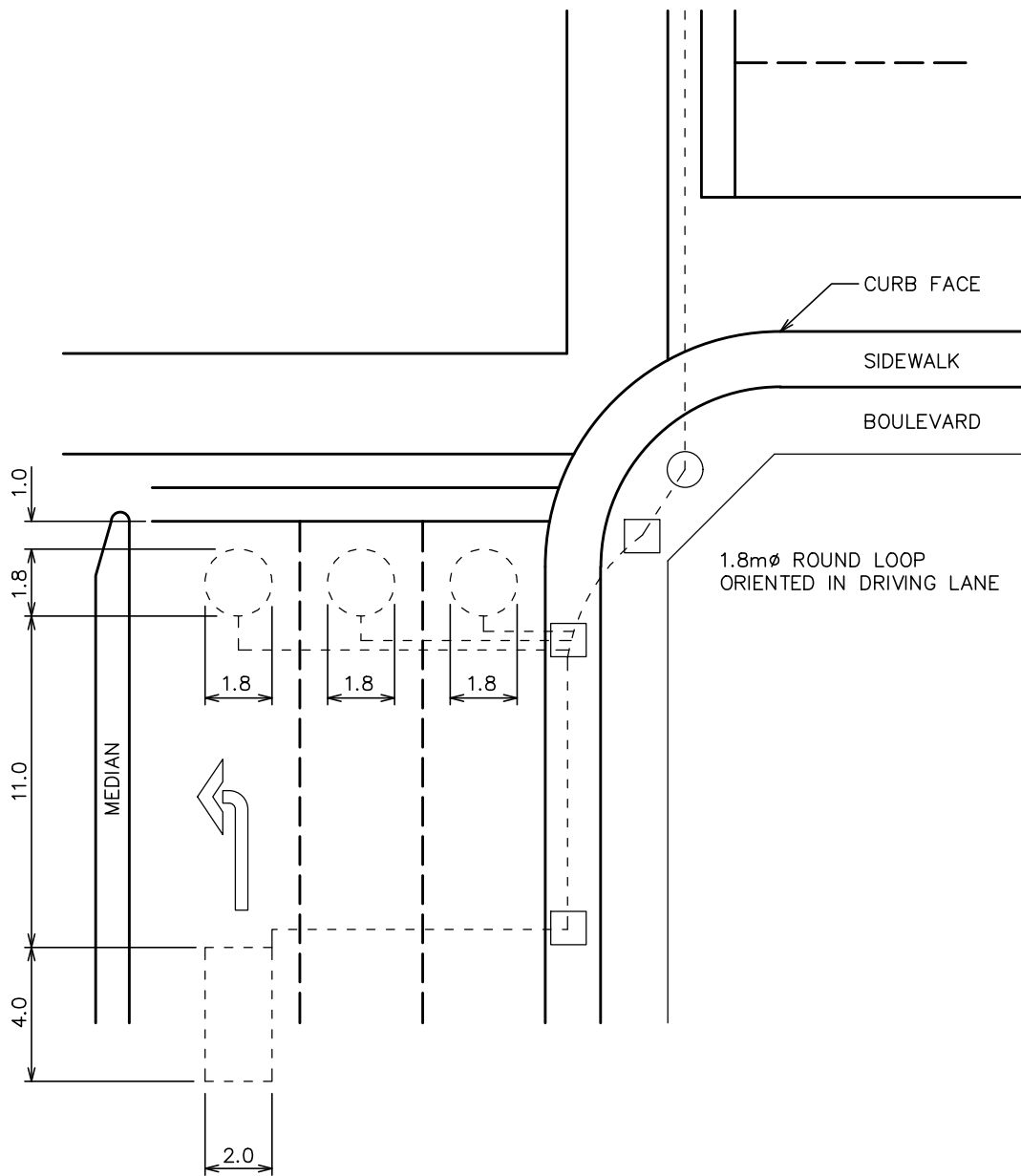

NOTES: (1) LOOPS SHALL BE LOCATED IN THE CENTRE OF EACH LANE UNLESS OTHERWISE NOTED ON CONTRACT DRAWINGS.

3			All Dimensions Shown In Metres, Unless Otherwise Noted
2	APRIL 2020	SCOTT NEUMAN	
1	JANUARY 2016	JAMIE BOAN	Title TYPICAL DETECTOR LOOP LOCATIONS
	Revision Date	Approved	
			Approved By : APRIL 2020 G.M. Engineering
SUPPLEMENTARY STANDARD DRAWINGS			DRAWING NUMBER SSD-R.E.12

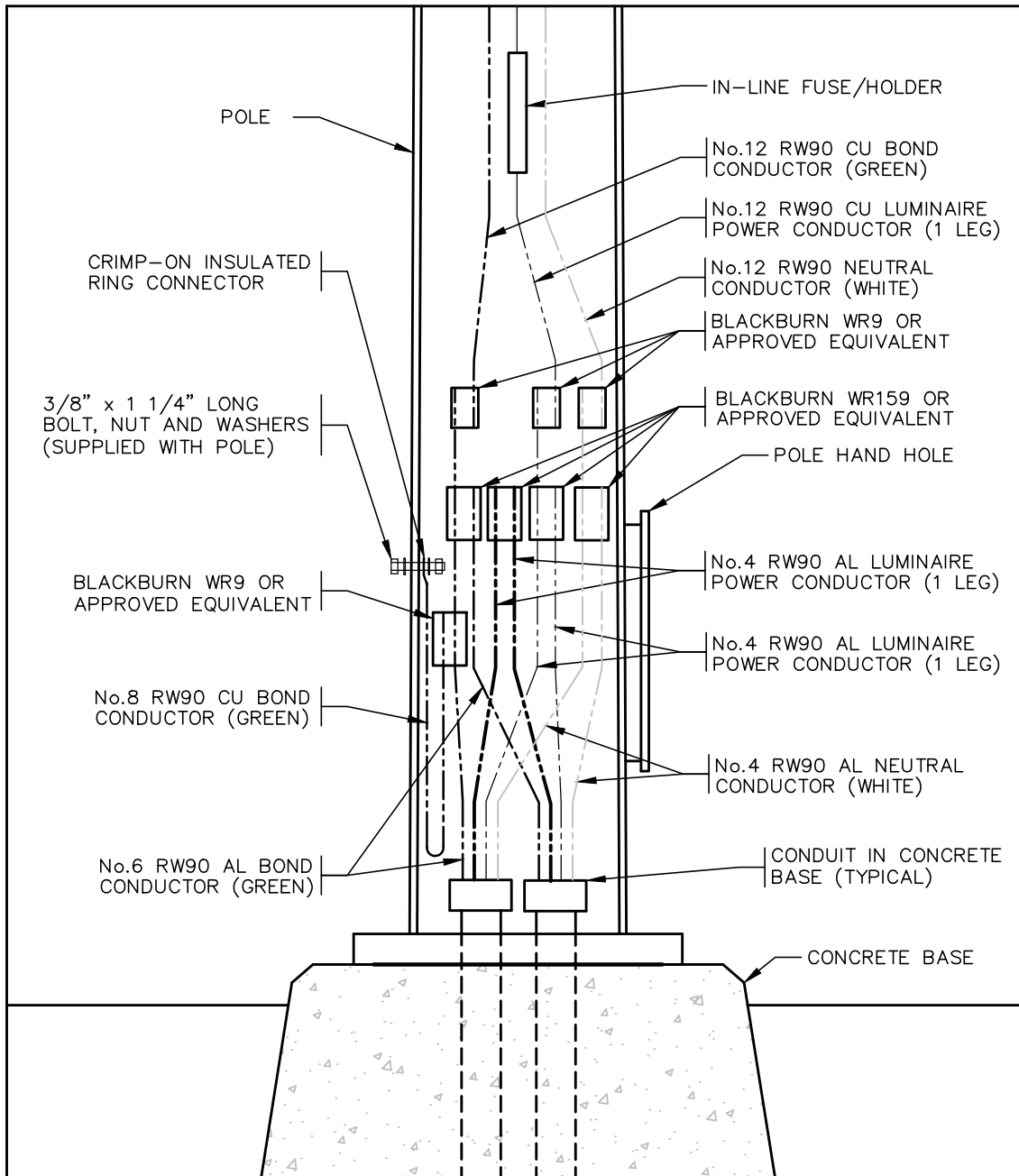

POLE ELEVATION/CROSS-SECTION

N.T.S.

LEGEND

- BOND CONDUCTOR
- POWER CONDUCTOR (1 LEG)
- POWER CONDUCTOR (1 LEG)
- NEUTRAL CONDUCTOR

3			All Dimensions Shown In Metres, Unless Otherwise Noted
2	APRIL 2020	SCOTT NEUMAN	
1	JANUARY 2016	JAMIE BOAN	Title LUMINAIRE WIRING IN POLE HAND HOLE
	Revision Date	Approved	
CITY OF SURREY <small>the future lives here.</small>			Approved By :
			 G.M. Engineering
			DRAWING NUMBER SSD-R.E.13
			APRIL 2020

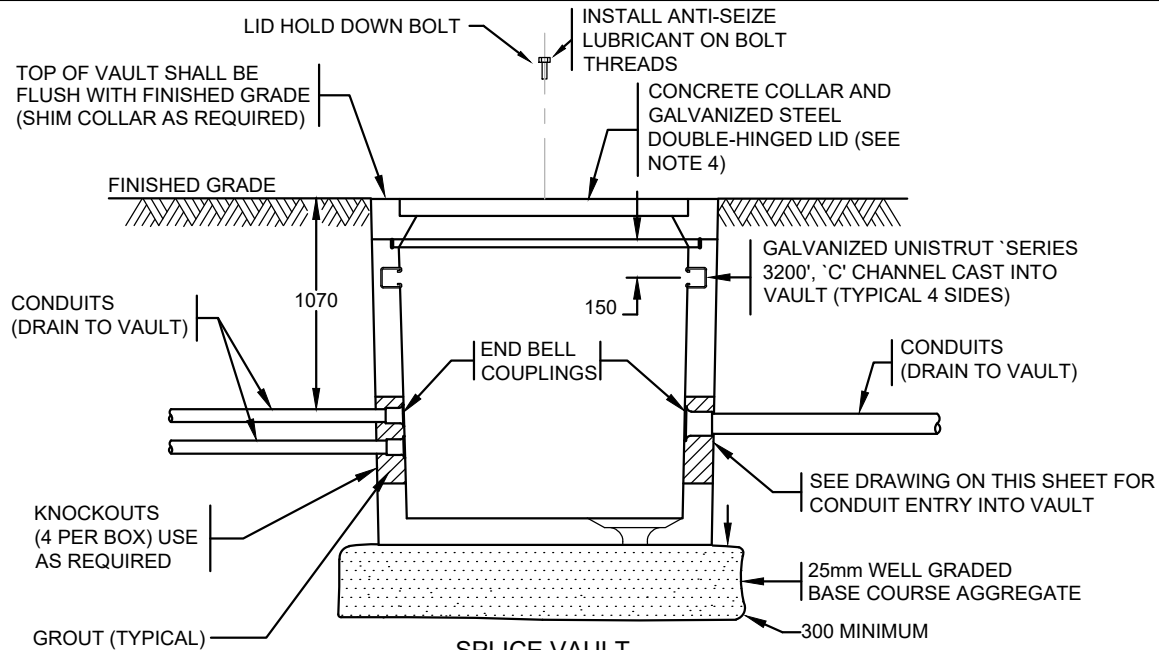

SPLICE VAULT

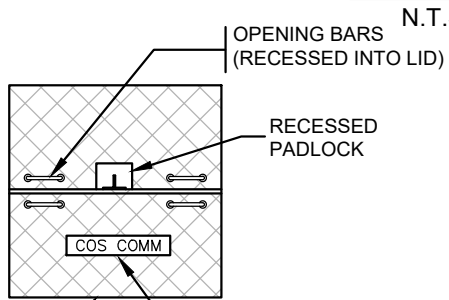

GALVANIZED LID DETAIL

FOR BOULEVARD INSTALLATION ONLY

NOTES

- FOR BOULEVARD INSTALLATIONS, VAULT SHALL BE PRE-CAST CONCRETE (1.2m OR 1.5m).
- VAULT LIDS SHALL BE SUPPLIED GALVANIZED.
- MANHOLE LID AND ROOF SLAB REQUIRED FOR INSTALLATIONS IN ROADWAYS AND SIDEWALKS ONLY.
- VAULTS SHALL BE C/W CONDUIT TERMINATOR STYLE CABLE RACK.
- REFER TO CONTRACT DRAWINGS, SECTION 34 41 13 FOR DETAILED SPECIFICATIONS.
- JUNCTION BOX SHALL BE DESIGNED FOR 5000kg STATIC LOADING.
- VAULTS SHALL BE PRE-CAST CONCRETE WITH MINIMUM COMPRESSIVE STRENGTH OF 35MPa AT 28 DAYS.
- ALL DIMENSIONS ARE IN MILLIMETERS UNLESS OTHERWISE NOTED.

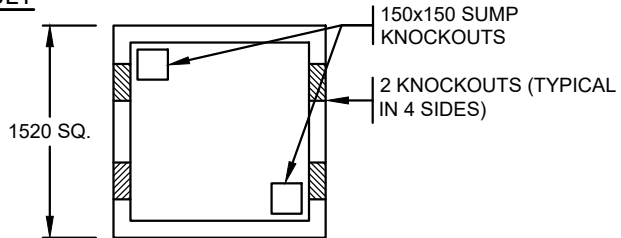

PLAN VIEW

KNOCKOUT & SUMP LOCATION
FOR INSTALLATION IN BOULEVARDS ONLY
N.T.S.

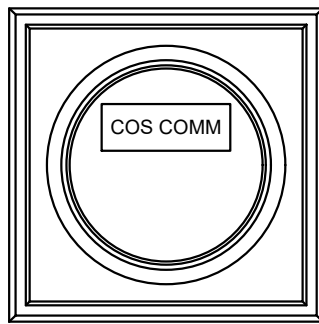

PLAN VIEW

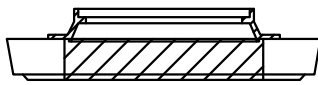

SIDE VIEW

900Ø MANHOLE LID DETAIL

FOR INSTALLATION IN ROADWAYS AND SIDEWALKS ONLY
N.T.S.

3		
2		
1	APRIL 2020	SCOTT NEUMAN
	Revision Date	Approved

All Dimensions Shown In Millimetres, Unless Otherwise Noted	
Title	COMMUNICATION CONDUIT VAULTS





SUPPLEMENTARY STANDARD DRAWINGS

Approved By : *[Signature]*
APRIL 2020 G.M. Engineering

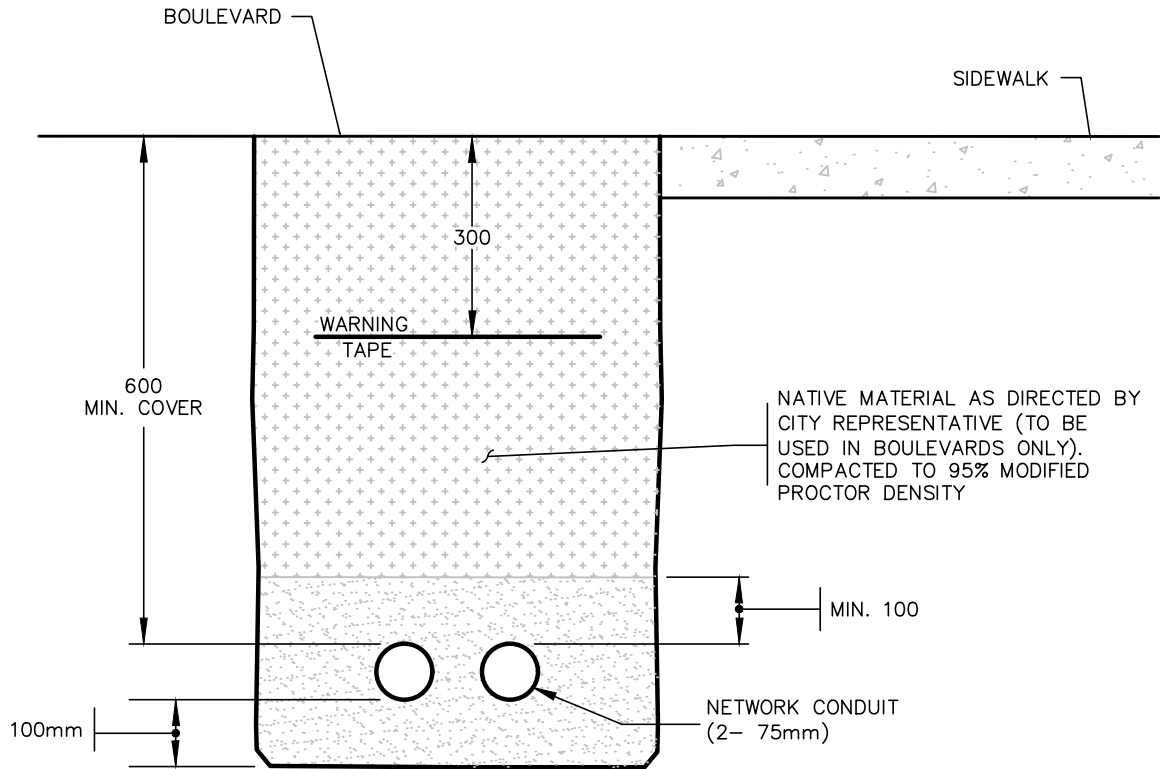
DRAWING NUMBER
SSD-E10.11



3			All Dimensions Shown In Millimetres, Unless Otherwise Noted
2			
1	APRIL 2020	VICTOR JHINGAN	Title COMMUNICATION CONDUIT UTILITY TRENCH
	Revision Date	Approved	
 <p>CITY OF SURREY the future lives here.</p>			Approved By :  APRIL 2020 G.M. Engineering
SUPPLEMENTARY STANDARD DRAWINGS			DRAWING NUMBER SSD-E10.12

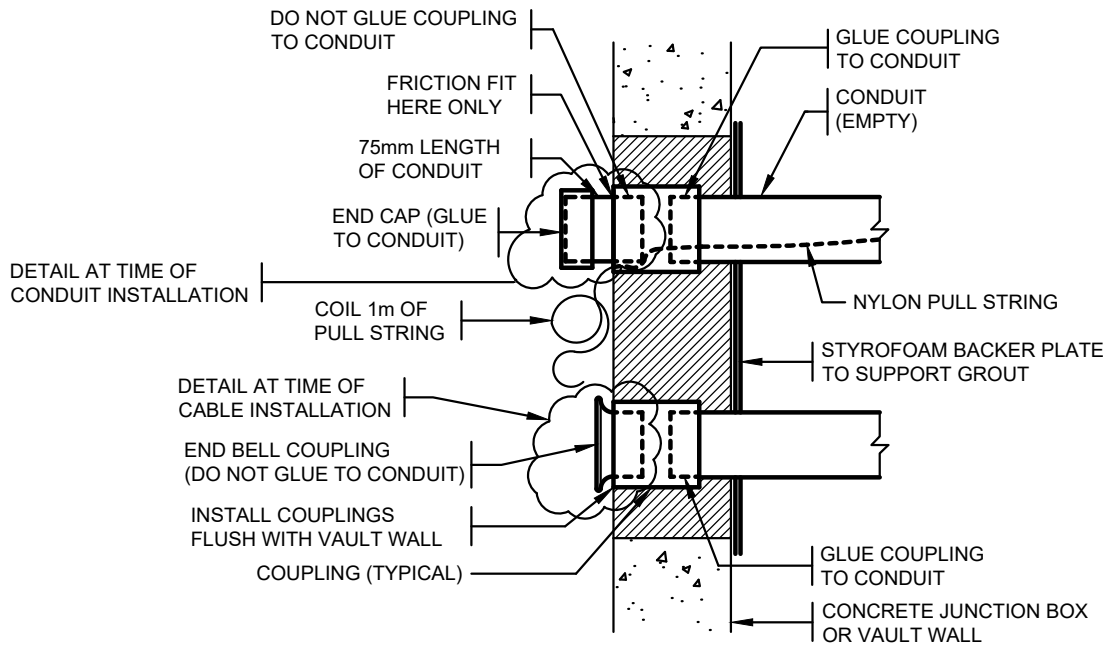

CONDUIT ENTRY INTO CONCRETE BOX/VAULT
N.T.S.

3			All Dimensions Shown In Millimetres, Unless Otherwise Noted
2			
1	APRIL 2020	VICTOR JHINGAN	Title
	Revision Date	Approved	COMMUNICATION CODUIT CONDUIT ENTRY DETAIL
		SUPPLEMENTARY STANDARD DRAWINGS	Approved By : APRIL 2020 G.M. Engineering
			DRAWING NUMBER SSD-E10.13

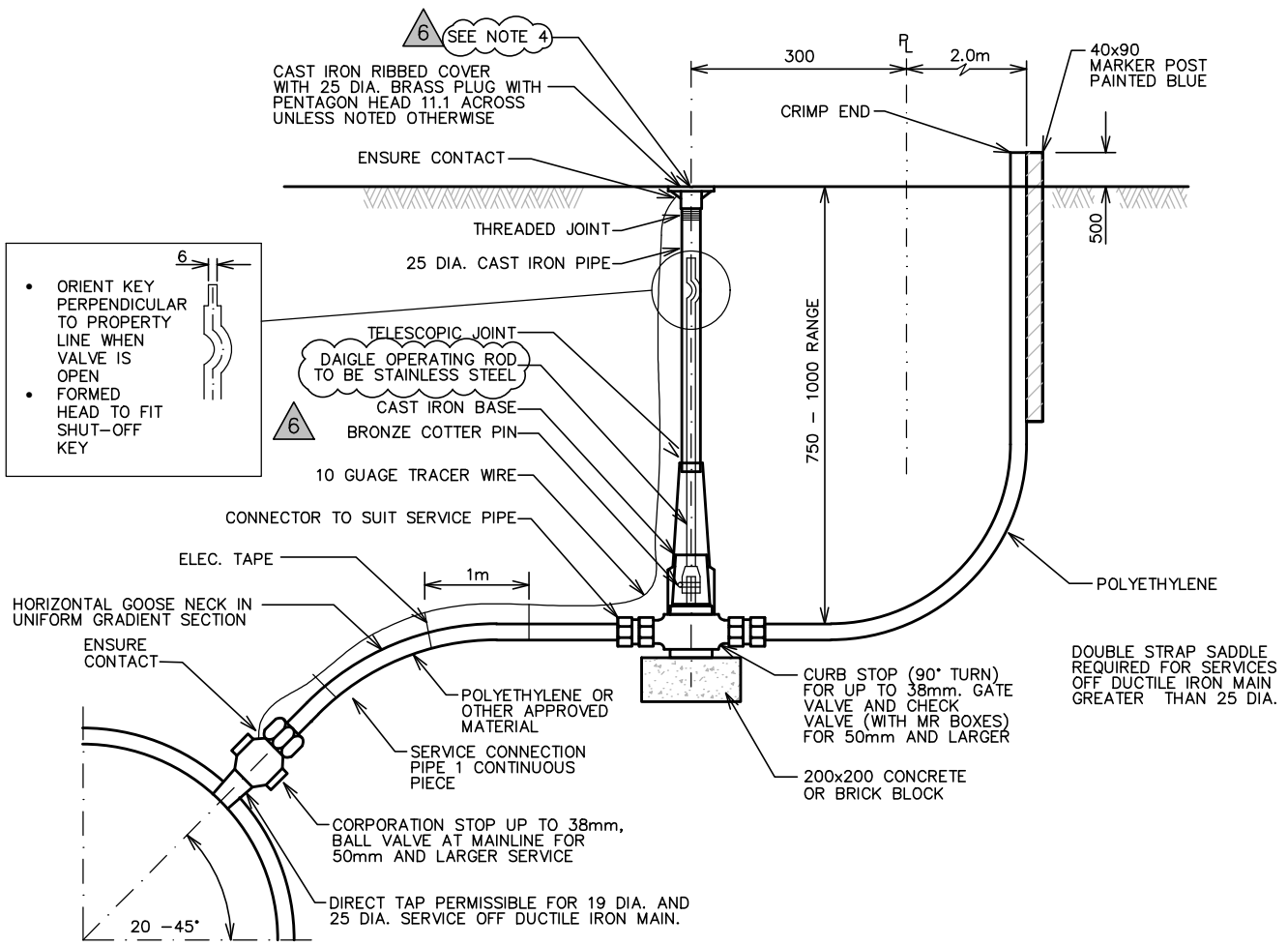

NOTES:

1. FOR ALL METER AND METER CHAMBER REQUIREMENTS, REFER TO "WATER METER AND SERVICE CONNECTION DESIGN CRITERIA MANUAL".
2. CONNECTIONS GREATER THAN 50 SHALL BE RESTRAINED TO THE CITY WATER MAIN.
3. ALL FITTINGS OVER 50 DIAMETER SHALL HAVE FLANGE OR HUB JOINTS.
4. WHEN CURB STOP INSTALLED IN DRIVEWAY PLACE IN CHAMBER. COVER MARKED 'WATER' SEE MMCD DRAWING S9 FOR TYPICAL DETAIL.
5. OPERATING ROD DIAMETERS
 - 14mm FOR 25mm OR SMALLER CURB STOPS
 - 19mm FOR 32mm TO 38mm CURB STOPS
6. TRACER WIRE SHALL BE ATTACHED TO CORP AND CURB STOPS WITH ANODE NUTS AND SECURED TO SERVICE PIPE @ 1m INCREMENTS USING ELECTRICAL TAPE, DO NOT COIL AROUND SERVICE PIPE.

6	APRIL 2020	KOK KUEN LI
5	JULY 2016	KOK KUEN LI
4	JANUARY 2016	KOK KUEN LI
	Revision Date	Approved

All Dimensions Shown In Millimeters,
Unless Otherwise Noted

Title **SINGLE FAMILY WATER SERVICE CONNECTION
19mm TO 50mm ONLY**



Approved By : *[Signature]*

APRIL 2020 G.M. Engineering

DRAWING NUMBER
SSD-W.1

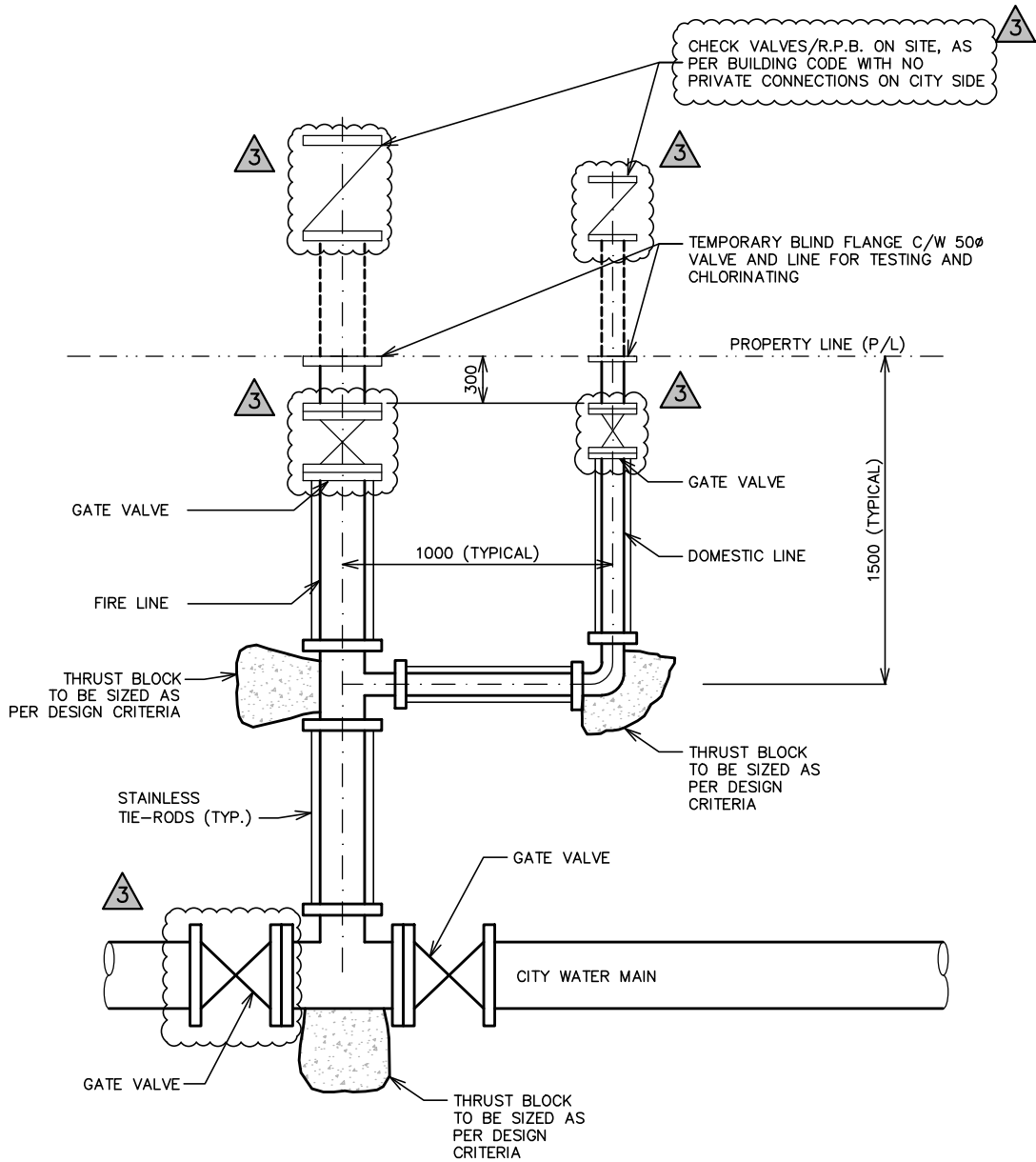

FIRELINE/DOMESTIC SERVICE CONNECTION

NOTES:

1. ALL CONNECTIONS TO BE CONTINUOUSLY RESTRAINED TO THE CITY WATER MAIN.

3	APRIL 2020	KOK KUEN LI
2	SEPTEMBER 2018	KOK KUEN LI
1	JANUARY 2016	KOK KUEN LI
	Revision Date	Approved

All Dimensions Shown In Millimeters, Unless Otherwise Noted	
Title	MULTI-FAMILY/INDUSTRIAL COMMERCIAL WATER SERVICE CONNECTION



CITY OF SURREY
 the future lives here.

SUPPLEMENTARY STANDARD DRAWINGS

Approved By : 

APRIL 2020 G.M. Engineering

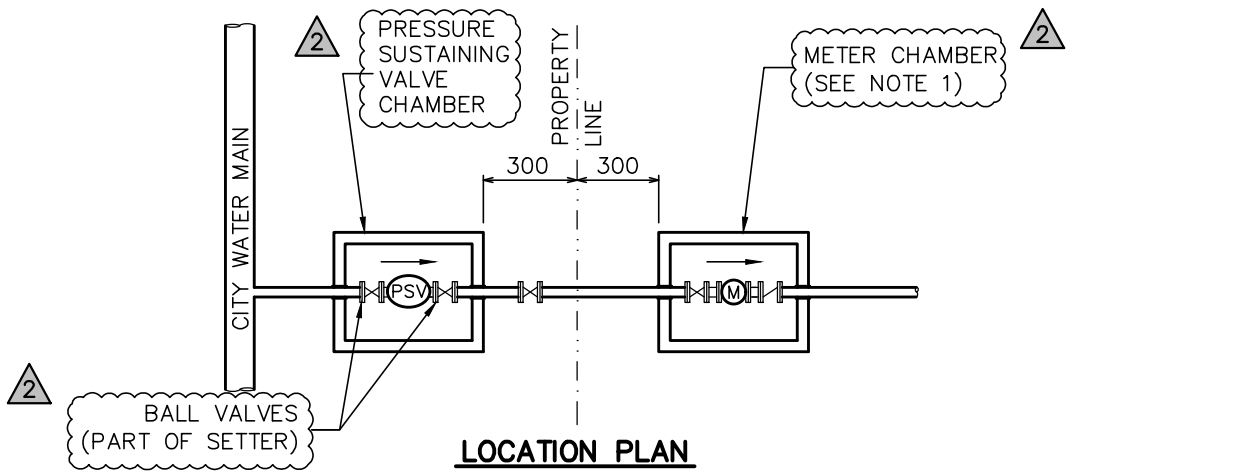
DRAWING NUMBER
SSD-W.2



LOCATION PLAN

100 STYROFOAM INSULATION CUT TO FIT METER BOX OPENING COVER PER WATER METER INSTALLATION & SPECIFICATIONS STD. (SEE NOTE 1)

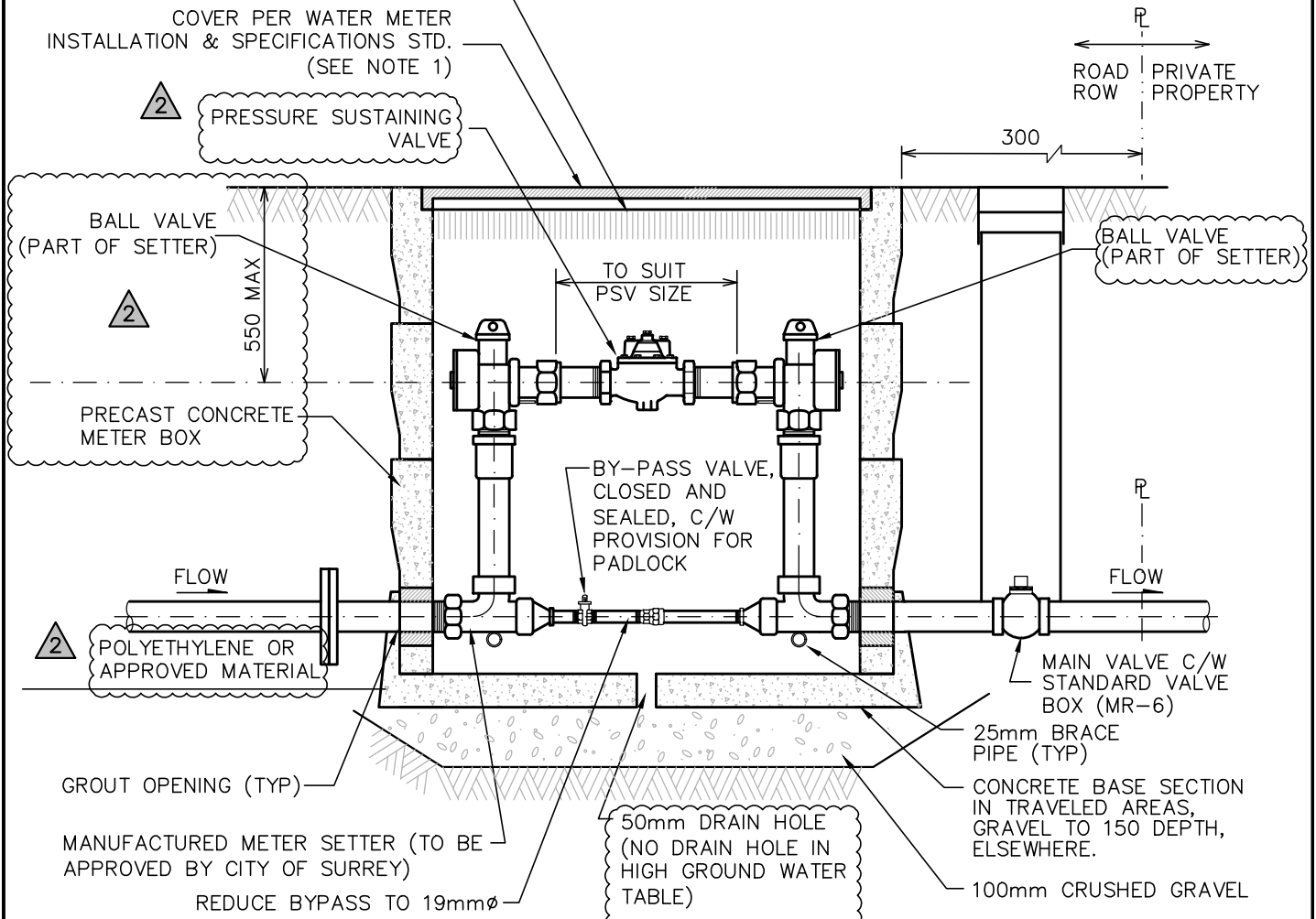

NOTES: (1) THIS DRAWING SHOULD BE REVIEWED IN CONJUNCTION WITH THE DOCUMENT "WATER METER AND SERVICE CONNECTION DESIGN CRITERIA MANUAL".

3		
2	APRIL 2020	KOK KUEN LI
1	JANUARY 2016	KOK KUEN LI
	Revision Date	Approved

All Dimensions Shown In Millimeters, Unless Otherwise Noted

Title **50mm PRESSURE SUSTAINING VALVE & CHAMBER INSTALLATION**



Approved By : *[Signature]*
APRIL 2020 G.M. Engineering

DRAWING NUMBER **SSD-W.3**

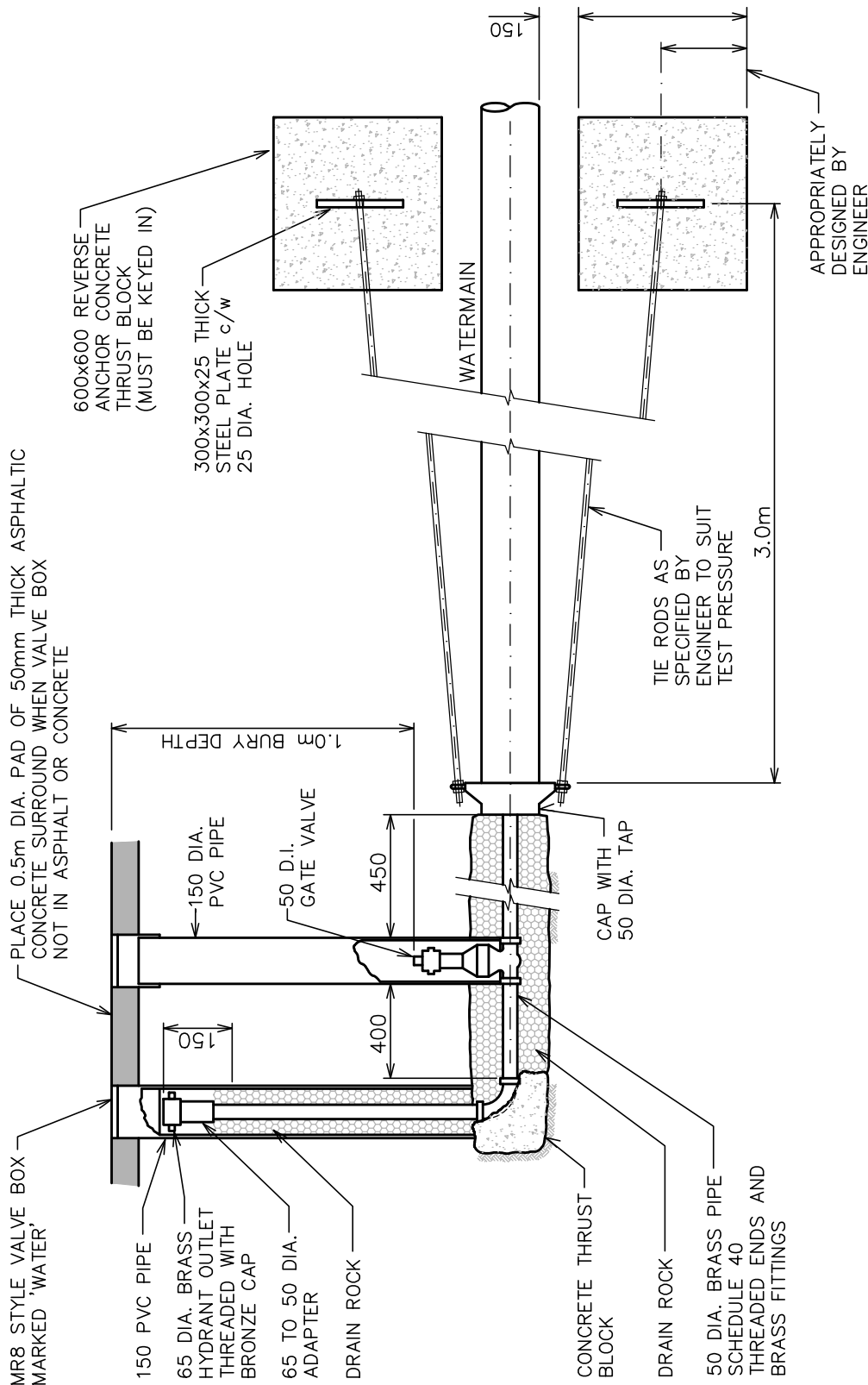

PROFILE VIEW

PLAN VIEW

- NOTES:
1. TEMPORARY BLOW-OFFS PIPE MATERIAL TO BE GALVANIZED INSTEAD OF BRASS.
 2. 50 DIA. GATE VALVES TO BE AVK OR MUELLER.
 3. DOUBLE NUT TIE RODS AT REVERSE ANCHOR PLATES & CAP.
 4. THRUST BLOCKS OF 20MPa CONCRETE TO BE PLACED AGAINST UNDISTURBED GROUND.

3		
2	APRIL 2020	SCOTT NEUMAN
1	JANUARY 2016	KOK KUEN LI
	Revision Date	Approved

All Dimensions Shown In Millimeters, Unless Otherwise Noted	
Title	BLOW-OFF CHAMBER

SUPPLEMENTARY STANDARD DRAWINGS

Approved By :

APRIL 2020 G.M. Engineering

DRAWING NUMBER
SSD-W.4

R



SEE DRAWING MMCD W3 FOR GATE VALVE INSTALLATION. (VALVE TO BE NORMALLY CLOSED. LID PAINTED RED) PLACE 2X4 TALKING STICK PAINTED RED WITH INSTRUCTIONS FROM THE CITY OF SURREY INSIDE RISER PIPE

THREADED END AND CAP (WATER TIGHT SEAL) WITH LOCKING MECHANISM
APPROVED FRAME AND COVER H20 RATED WITH 762mm DIA OPENING MARKED "WATER"

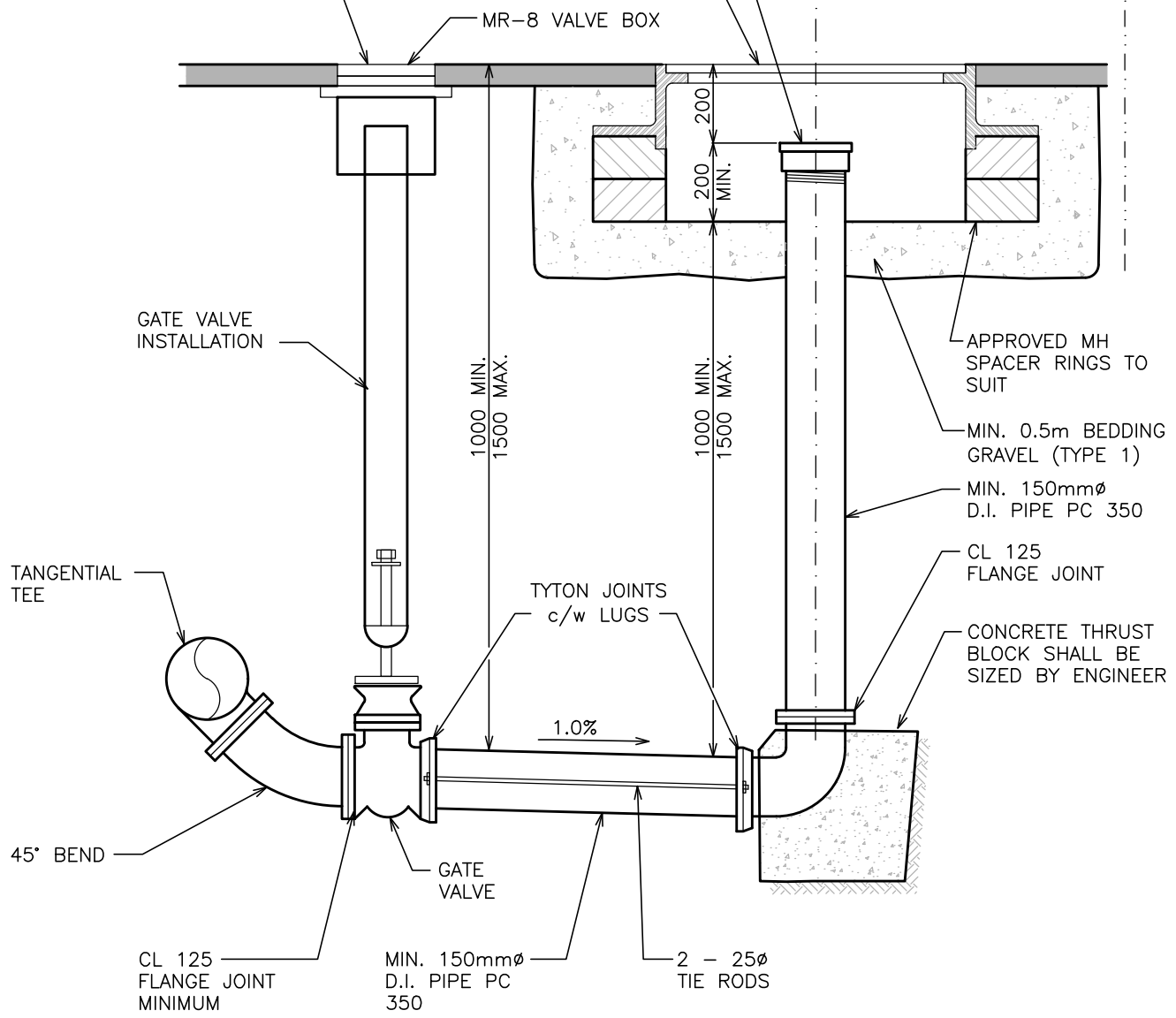
AS SHOWN ON CONTRACT DRAWINGS MIN. 2.0m



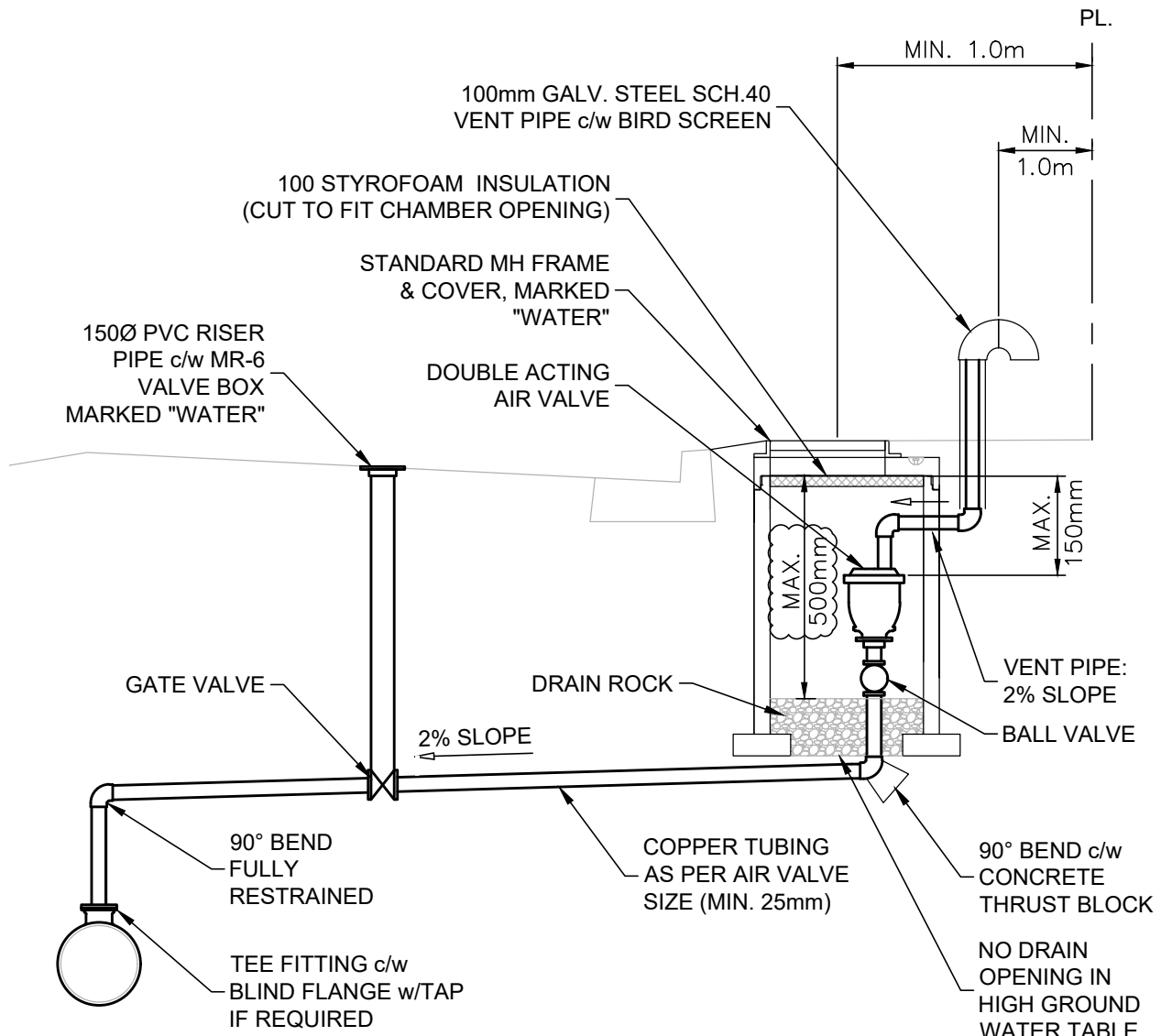

NOTES: (1) COMBINATION AIR VALVE & CHAMBER IS REQUIRED AT THE HIGH END OF THE ISOLATED SECTION OF WATERMAIN TO BE BLOWN DOWN.

3			All Dimensions Shown In Millimeters, Unless Otherwise Noted
2	APRIL 2020	SCOTT NEUMAN	
1	JANUARY 2016	KOK KUEN LI	
	Revision Date	Approved	Title BLOW DOWN CHAMBER
 SUPPLEMENTARY STANDARD DRAWINGS			Approved By :  APRIL 2020 G.M. Engineering
			DRAWING NUMBER SSD-W.5



- NOTES:
1. LARGER SIZE AIR VALVE CHAMBER IS TO BE DESIGNED BY THE CONSULTANT TO ACCOMMODATE DOUBLE BLOCK AND BLEED REQUIREMENTS.
 2. REFER TO CONTRACT DRAWINGS, SECTION 31 23 01 FOR DETAILED SPECIFICATIONS.
 3. VENT LOCATION IS FLEXIBLE TO OPTIMIZE CHAMBER PLACEMENT WITHIN BOULEVARDS.
 4. PIPES AND FITTINGS SHALL BE SIZED TO ACCOMMODATE AIR VALVE.

3			All Dimensions Shown In Millimetres, Unless Otherwise Noted	
2				
1	APRIL 2020	KOK KUEN LI	Title	
	Revision Date	Approved	COMBINATION AIR VALVE	
		SUPPLEMENTARY STANDARD DRAWINGS	Approved By : 	DRAWING NUMBER SSD-W.6
			APRIL 2020	G.M. Engineering

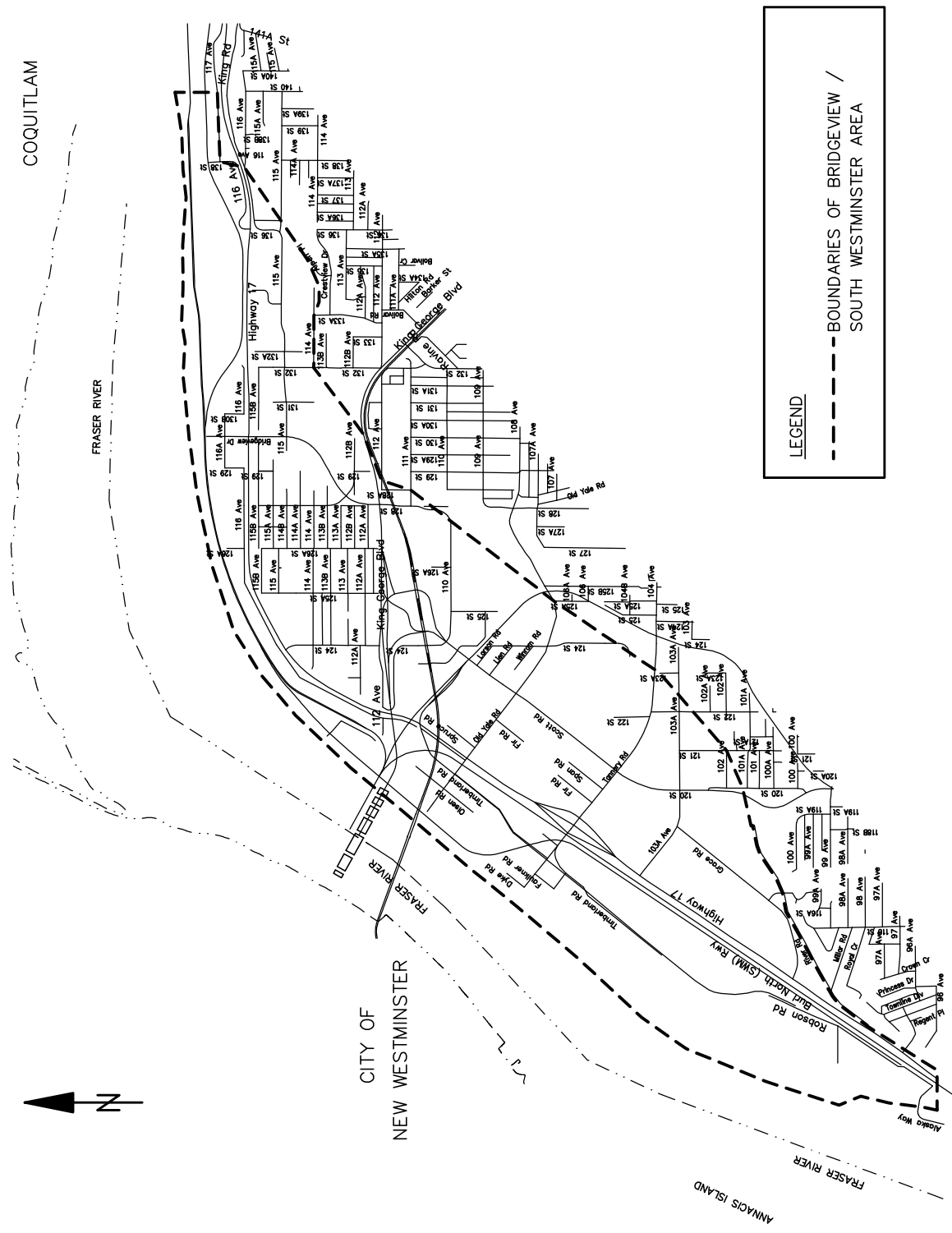

3		
2	APRIL 2020	SCOTT NEUMAN
1	JANUARY 2016	SCOTT NEUMAN
	Revision Date	Approved

All Dimensions Shown In Millimetres,
Unless Otherwise Noted

Title
BRIDGEVIEW / SOUTH WESTMINSTER AREA



Approved By : *[Signature]*

APRIL 2020 G.M. Engineering

DRAWING NUMBER
SSD-U.1.1

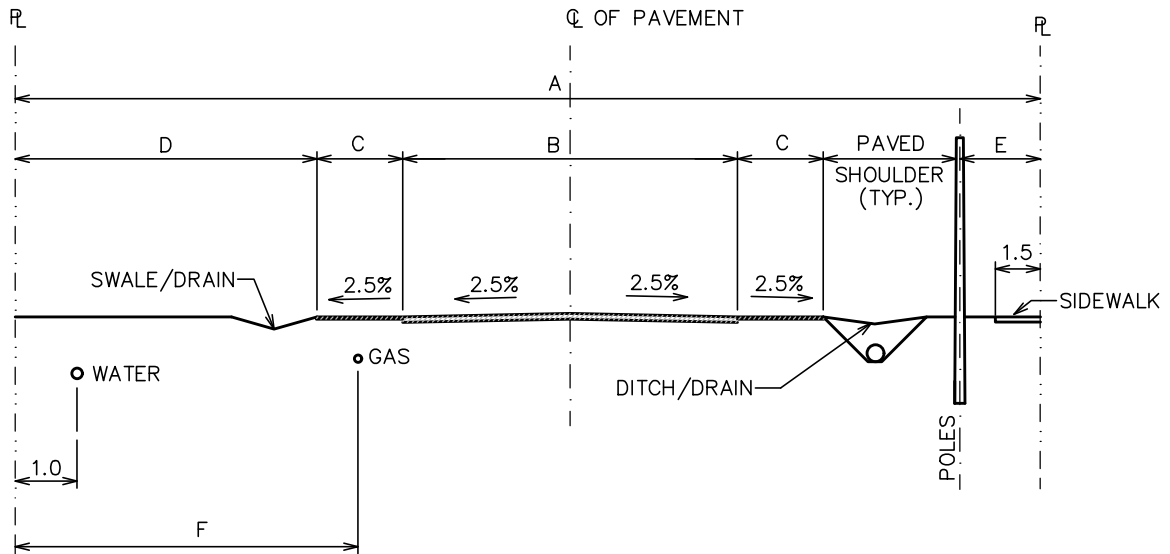



A	B	C	D	E	F
20	11.0	2.0	1.75	1.8	2.75
20	12.2	2.0	1.2	1.8	2.2
24	14.0	2.0	3.0	1.8	4.0

BRIDGEVIEW-SOUTH WESTMINSTER⁽¹⁾
EXCEPT RF (F) ROADS

NOTES: (1) INTERIM STANDARD FOR ROADS NOT PRELOADED IN BRIDGEVIEW AND SOUTH WESTMINSTER;
 BUILT SUBJECT TO THE APPROVAL OF THE ENGINEER.

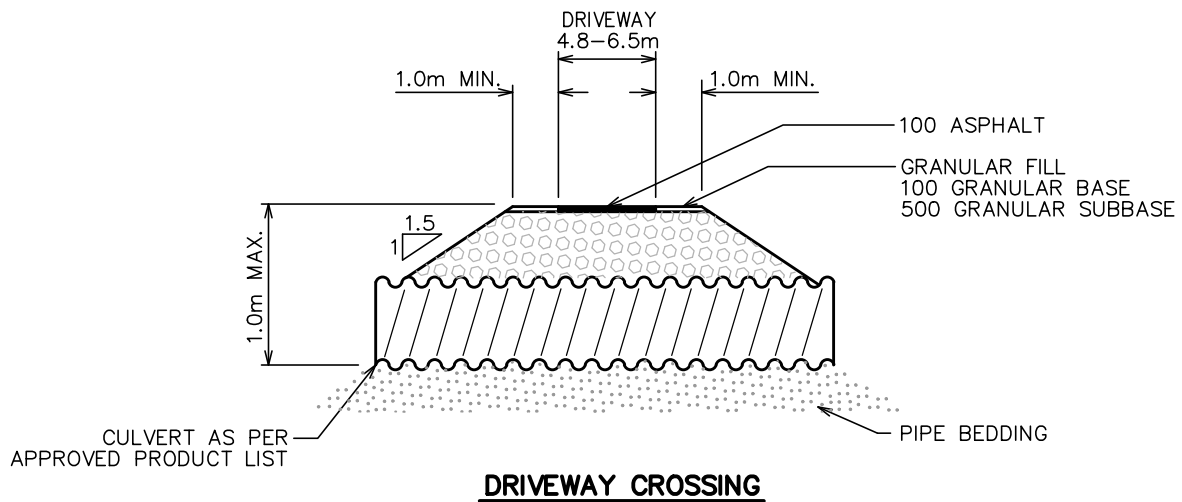
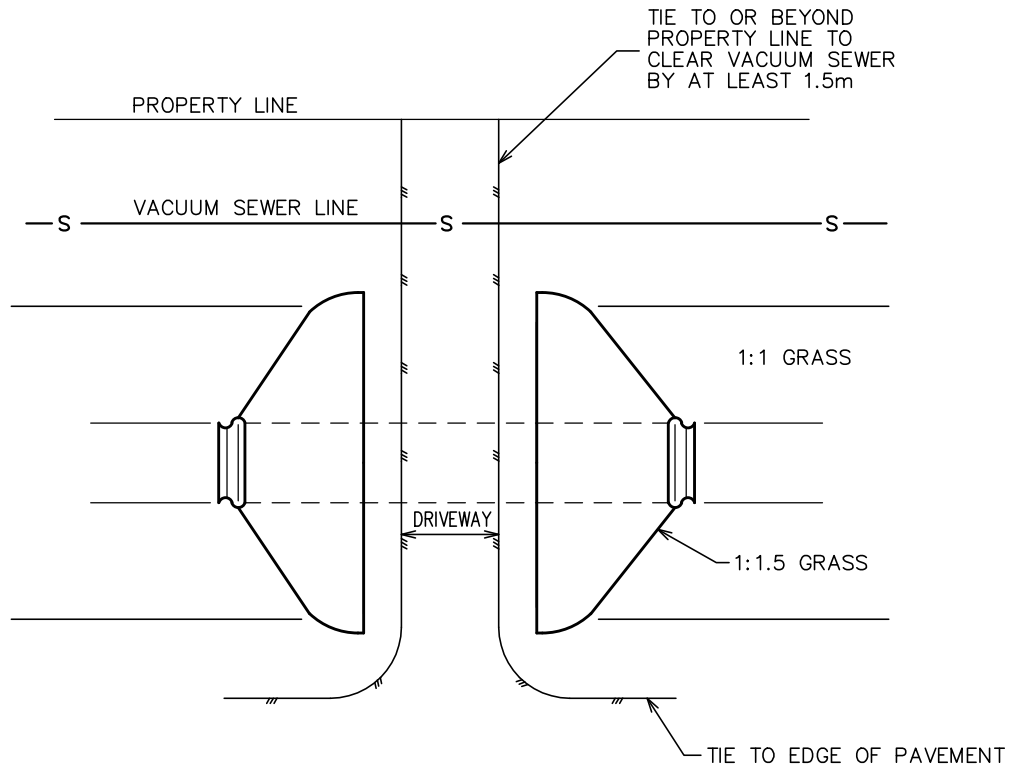
3		All Dimensions Shown In Metres, Unless Otherwise Noted
2	APRIL 2020 SCOTT NEUMAN	
1	JANUARY 2016 JAIME BOAN	
	Revision Date Approved	Title TYPICAL SECTION, ROAD WITHOUT CURB BRIDGEVIEW & SOUTH WESTMINSTER
		Approved By :
SUPPLEMENTARY STANDARD DRAWINGS		DRAWING NUMBER SSD-U.1.2
APRIL 2020		G.M. Engineering



3			All Dimensions Shown In Millimetres, Unless Otherwise Noted
2	APRIL 2020	SCOTT NEUMAN	
1	JANUARY 2016	CAROLYN BARON	Title
	Revision Date	Approved	RESIDENTIAL DRIVEWAY CROSSING BRIDGEVIEW & SOUTH WESTMINSTER
 <p>CITY OF SURREY the future lives here.</p>			Approved By :
<p>SUPPLEMENTARY STANDARD DRAWINGS</p>			 APRIL 2020 G.M. Engineering
			DRAWING NUMBER SSD-U.1.3

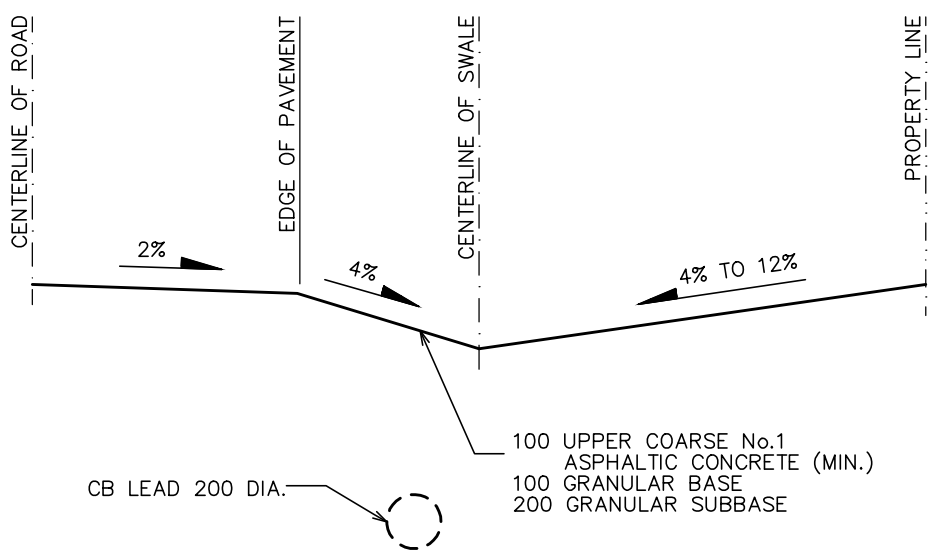
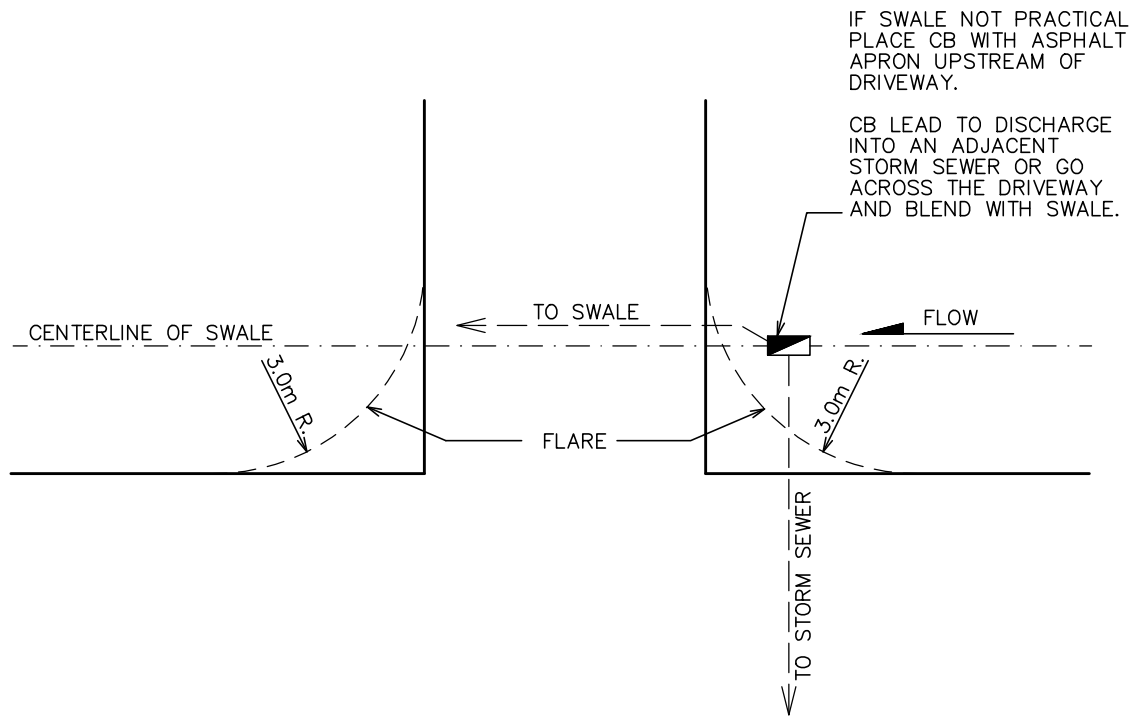

SECTION THROUGH DRIVEWAY

3			All Dimensions Shown In Millimetres, Unless Otherwise Noted
2	APRIL 2020	SCOTT NEUMAN	
1	JANUARY 2016	JAIME BOAN	Title DRIVEWAY FOR ROADS WITHOUT CURBS & SWALE BRIDGEVIEW & SOUTH WESTMINSTER
	Revision Date	Approved	
			Approved By :
SUPPLEMENTARY STANDARD DRAWINGS			DRAWING NUMBER SSD-U.1.4
			APRIL 2020 G.M. Engineering

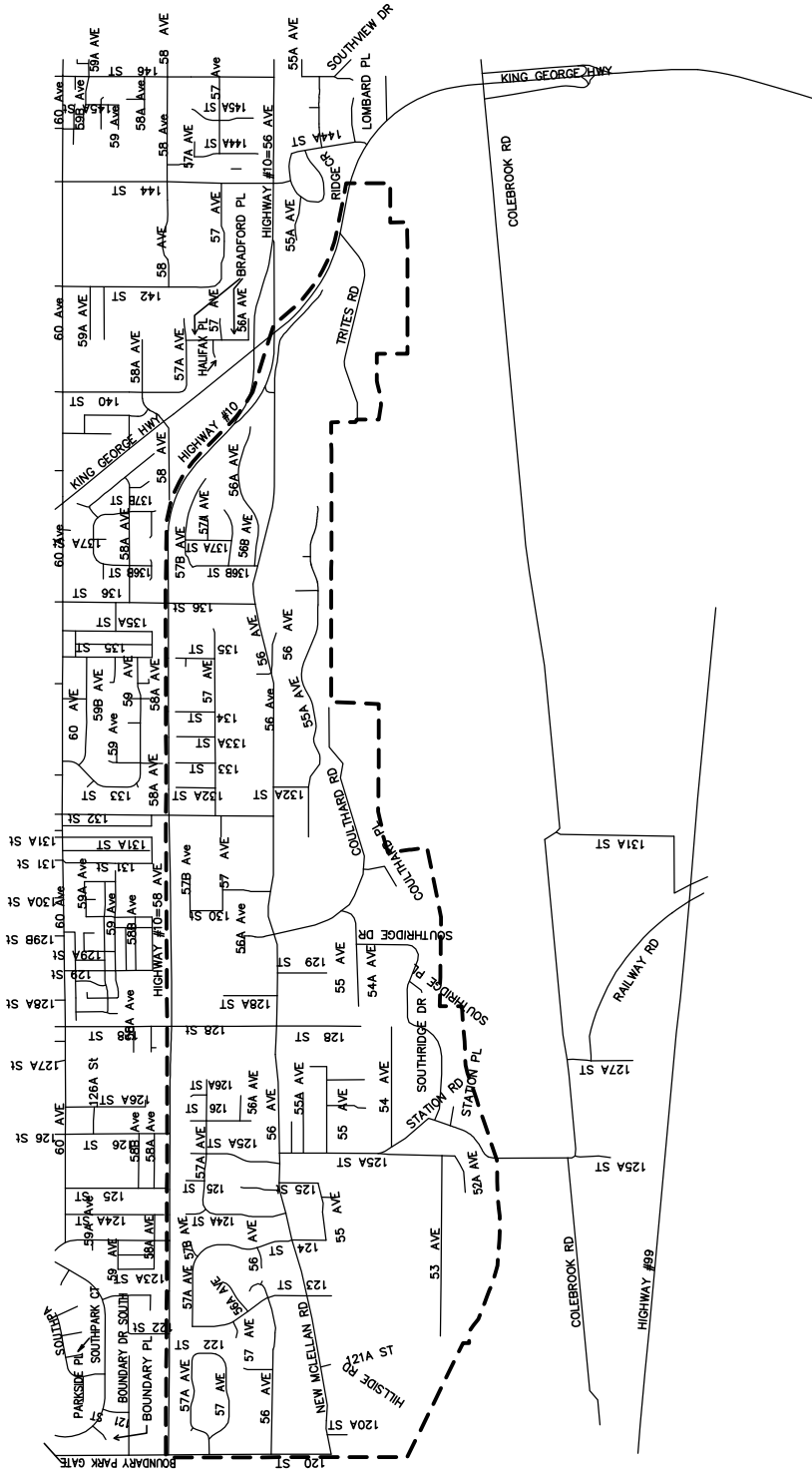
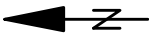

LEGEND

--- BOUNDARIES OF WEST PANORAMA RIDGE

3		
2	APRIL 2020	SCOTT NEUMAN
1	JANUARY 2016	SCOTT NEUMAN
	Revision Date	Approved

All Dimensions Shown In Millimetres, Unless Otherwise Noted

Title **WEST PANORAMA RIDGE AREA**



SUPPLEMENTARY STANDARD DRAWINGS

Approved By : 
 APRIL 2020 G.M. Engineering

DRAWING NUMBER
SSD-U.2

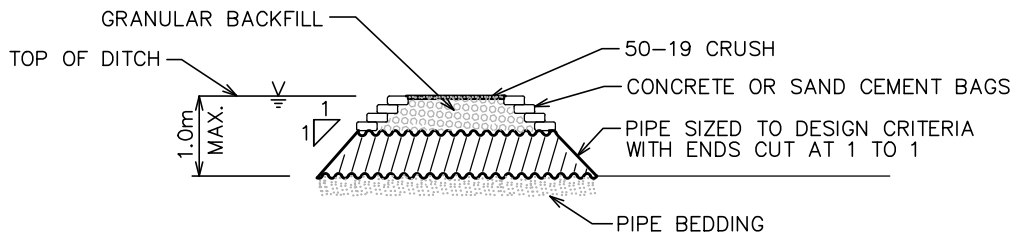
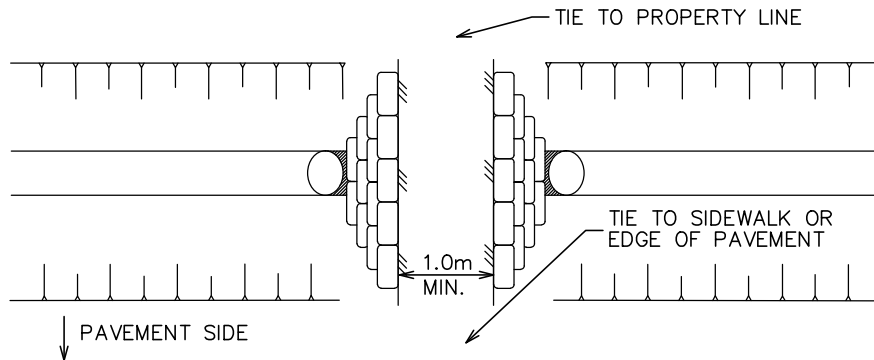
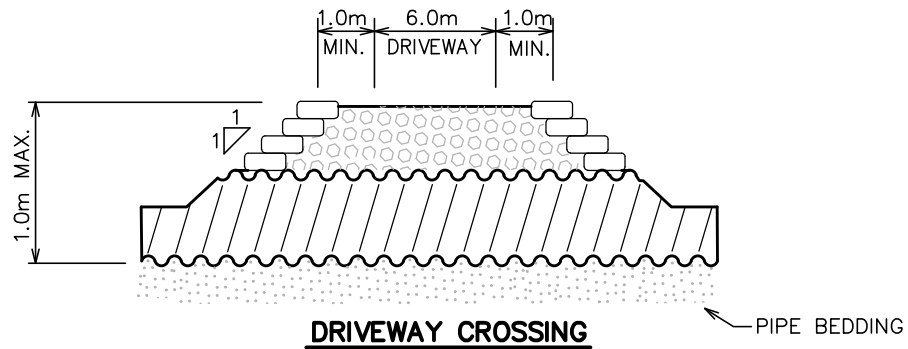
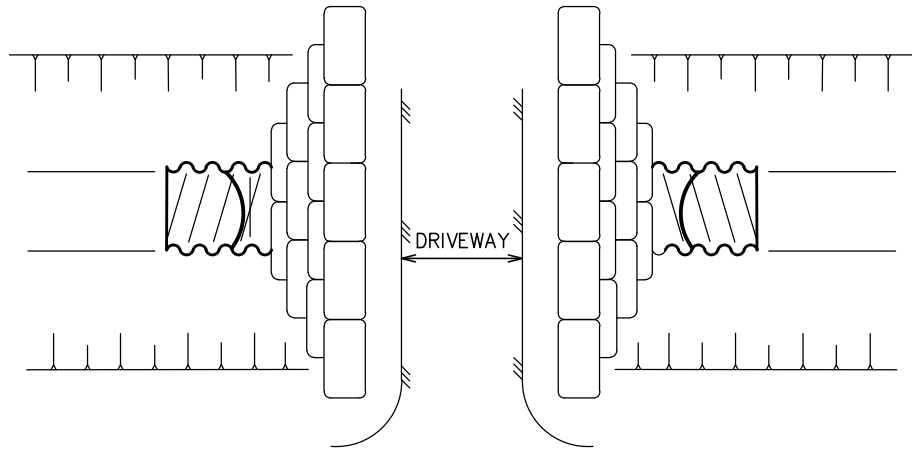

PEDRESTRIAN DITCH CROSSING

3			All Dimensions Shown In Millimetres, Unless Otherwise Noted
2	APRIL 2020	SCOTT NEUMAN	
1	JANUARY 2016	JAIME BOAN	Title DITCH CROSSING WEST PANORAMA RIDGE
	Revision Date	Approved	
			Approved By :
SUPPLEMENTARY STANDARD DRAWINGS			APRIL 2020 G.M. Engineering
			DRAWING NUMBER SSD-U.2.1

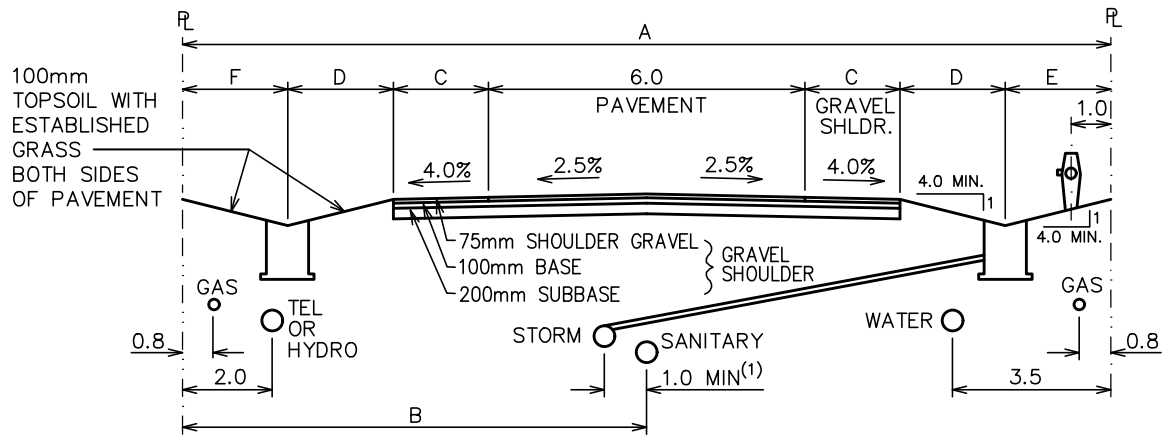

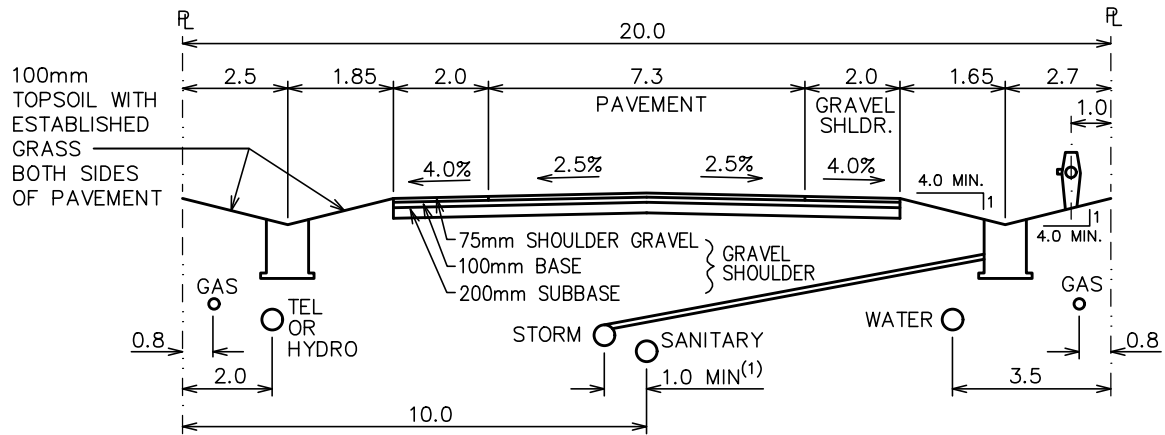

LOCAL

A	B	C	D	E	F
16.5	8.25	2.0	1.5	1.8	1.7
20.0	10.0	2.0	2.4	2.7	2.5



COLLECTOR

3			All Dimensions Shown In Metres, Unless Otherwise Noted
2	APRIL 2020	SCOTT NEUMAN	
1	JANUARY 2016	JAMIE BOAN	
	Revision Date	Approved	Title TYPICAL ROAD SECTIONS WEST PANORAMA RIDGE
 SUPPLEMENTARY STANDARD DRAWINGS			Approved By :  APRIL 2020 G.M. Engineering
			DRAWING NUMBER SSD-U.2.2

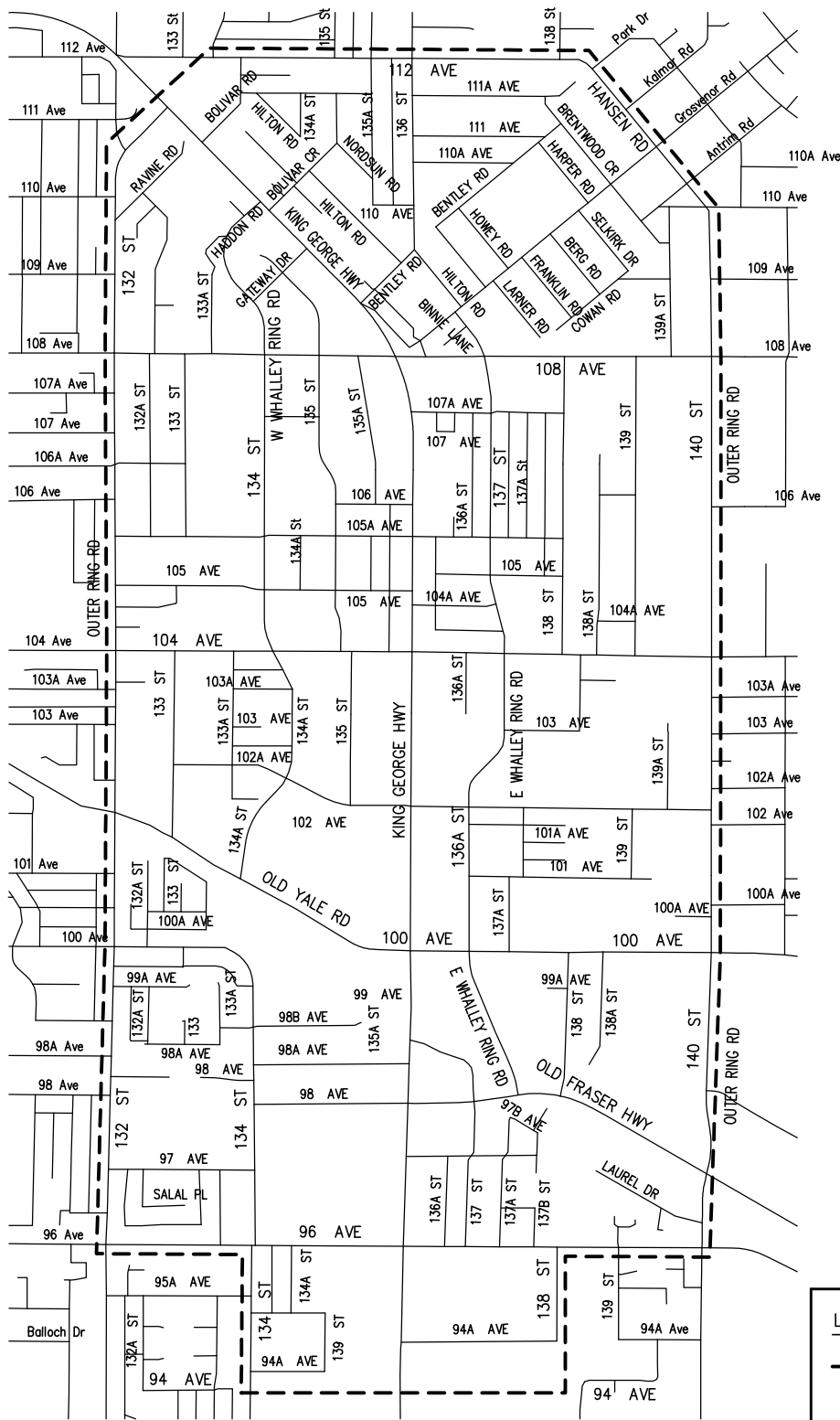

LEGEND
 - - - - - BOUNDARIES OF CITY CENTRE

3		
2	APRIL 2020	SCOTT NEUMAN
1	JANUARY 2016	SCOTT NEUMAN
	Revision Date	Approved

All Dimensions Shown In Millimetres,
 Unless Otherwise Noted

Title
SURREY CITY CENTRE AREA



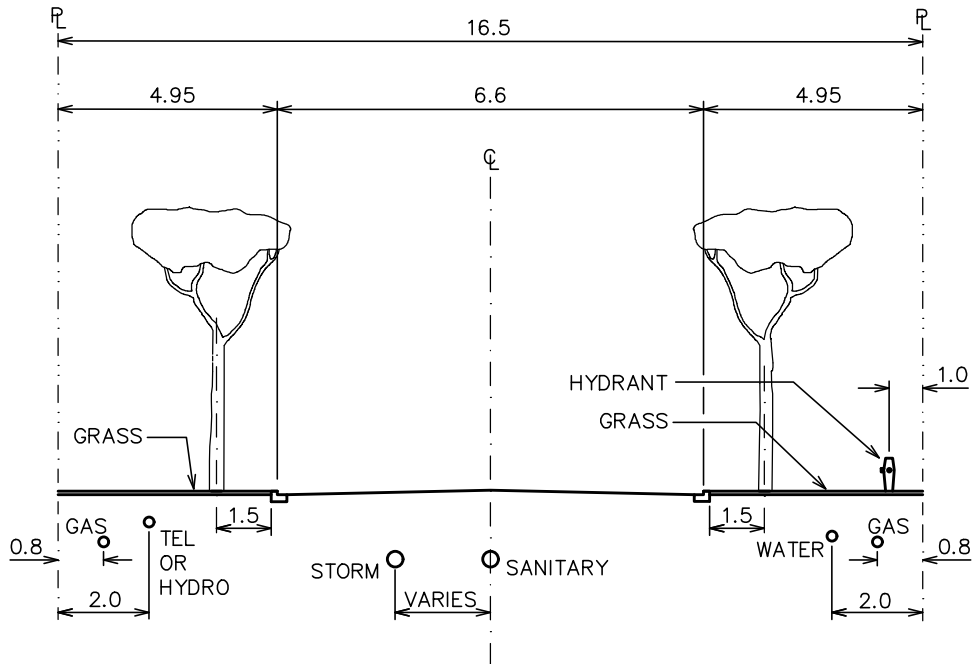

Approved By : 
 APRIL 2020 G.M. Engineering

DRAWING NUMBER
SSD-U.3



PROPOSED

NOTES: (1) STREET LIGHTS LOCATED 0.8m BACK FROM FACE OF CURB.

3			All Dimensions Shown In Metres, Unless Otherwise Noted
2	APRIL 2020	SCOTT NEUMAN	
1	JANUARY 2016	JAIME BOAN	Title LIMITED LOCAL ROAD SECTION, CENTRAL SEMIAHMOO
	Revision Date	Approved	
 CITY OF SURREY the future lives here.			Approved By :  APRIL 2020 G.M. Engineering
SUPPLEMENTARY STANDARD DRAWINGS			DRAWING NUMBER SSD-U.4.1

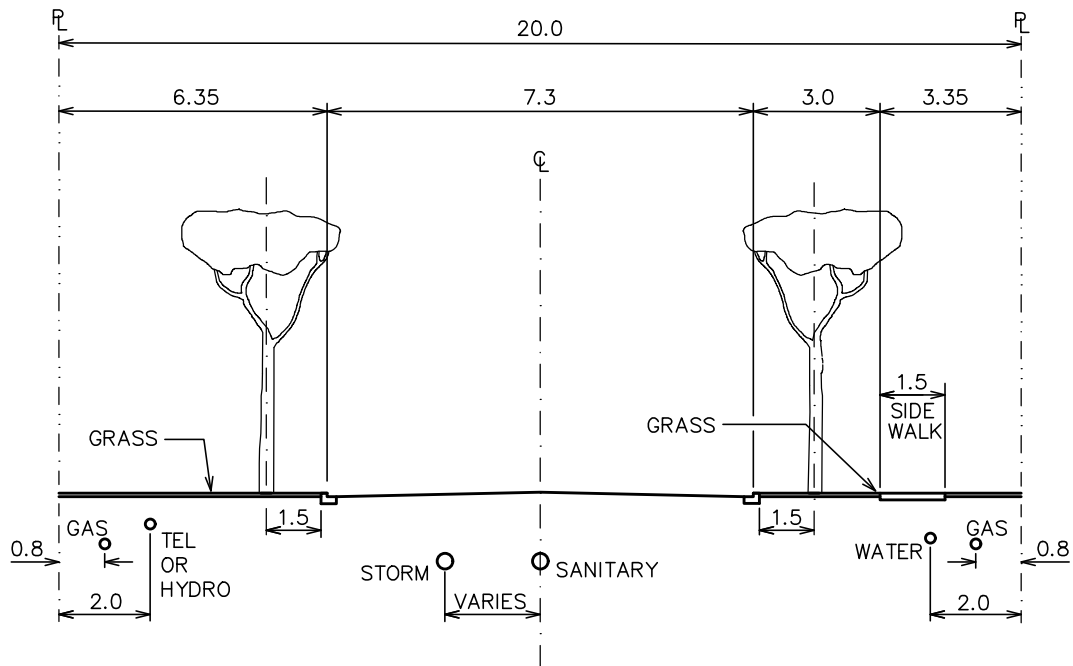

PROPOSED

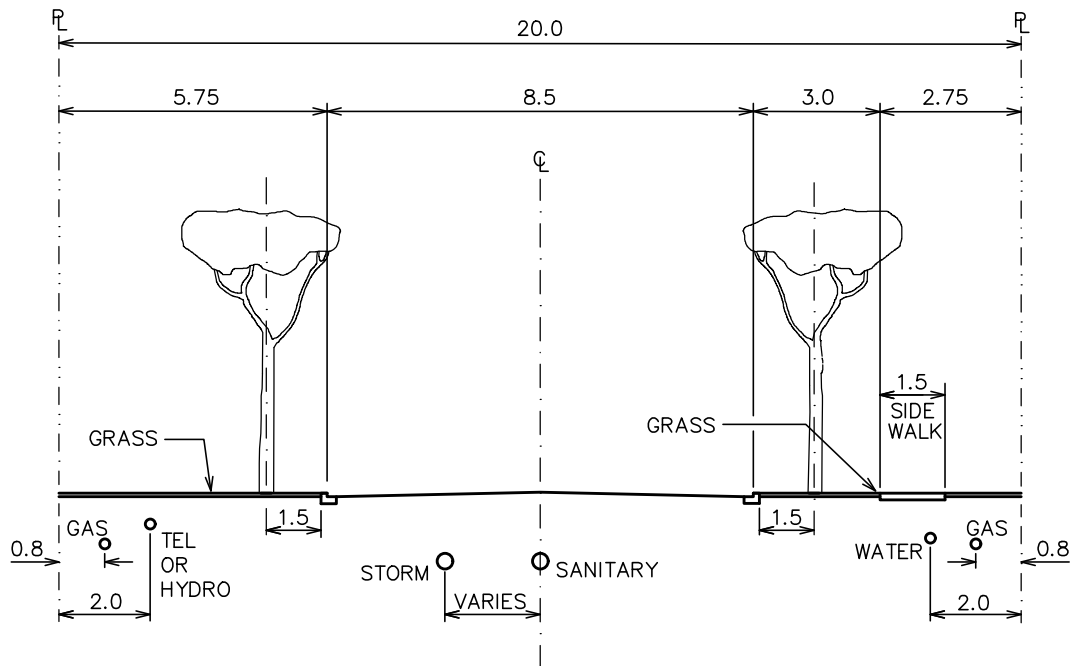

- NOTES: (1) STREET LIGHTS LOCATED 0.8m BACK FROM FACE OF CURB.
 (2) HYDRANTS LOCATED 1.0m INTO BOULEVARD FROM EDGE OF SIDEWALK.

3			All Dimensions Shown In Metres, Unless Otherwise Noted
2	APRIL 2020	SCOTT NEUMAN	
1	JANUARY 2016	JAIME BOAN	Title LOCAL THROUGH ROAD SECTION, CENTRAL SEMIAHMOO
	Revision Date	Approved	
			Approved By : APRIL 2020 G.M. Engineering
SUPPLEMENTARY STANDARD DRAWINGS			



PROPOSED

- NOTES: (1) STREET LIGHTS LOCATED 0.8m BACK FROM FACE OF CURB.
 (2) HYDRANTS LOCATED 1.0m INTO BOULEVARD FROM EDGE OF SIDEWALK.

3			All Dimensions Shown In Metres, Unless Otherwise Noted
2	APRIL 2020	SCOTT NEUMAN	
1	JANUARY 2016	JAIME BOAN	
	Revision Date	Approved	Title LIMITED OR THROUGH COLLECTOR ROAD SECTION, CENTRAL SEMIAHMOO
 CITY OF SURREY the future lives here.			Approved By :  APRIL 2020 G.M. Engineering
SUPPLEMENTARY STANDARD DRAWINGS			DRAWING NUMBER SSD-U.4.3



LEGEND
 - - - - - BOUNDARIES OF SURREY CITY CENTRE AREAS

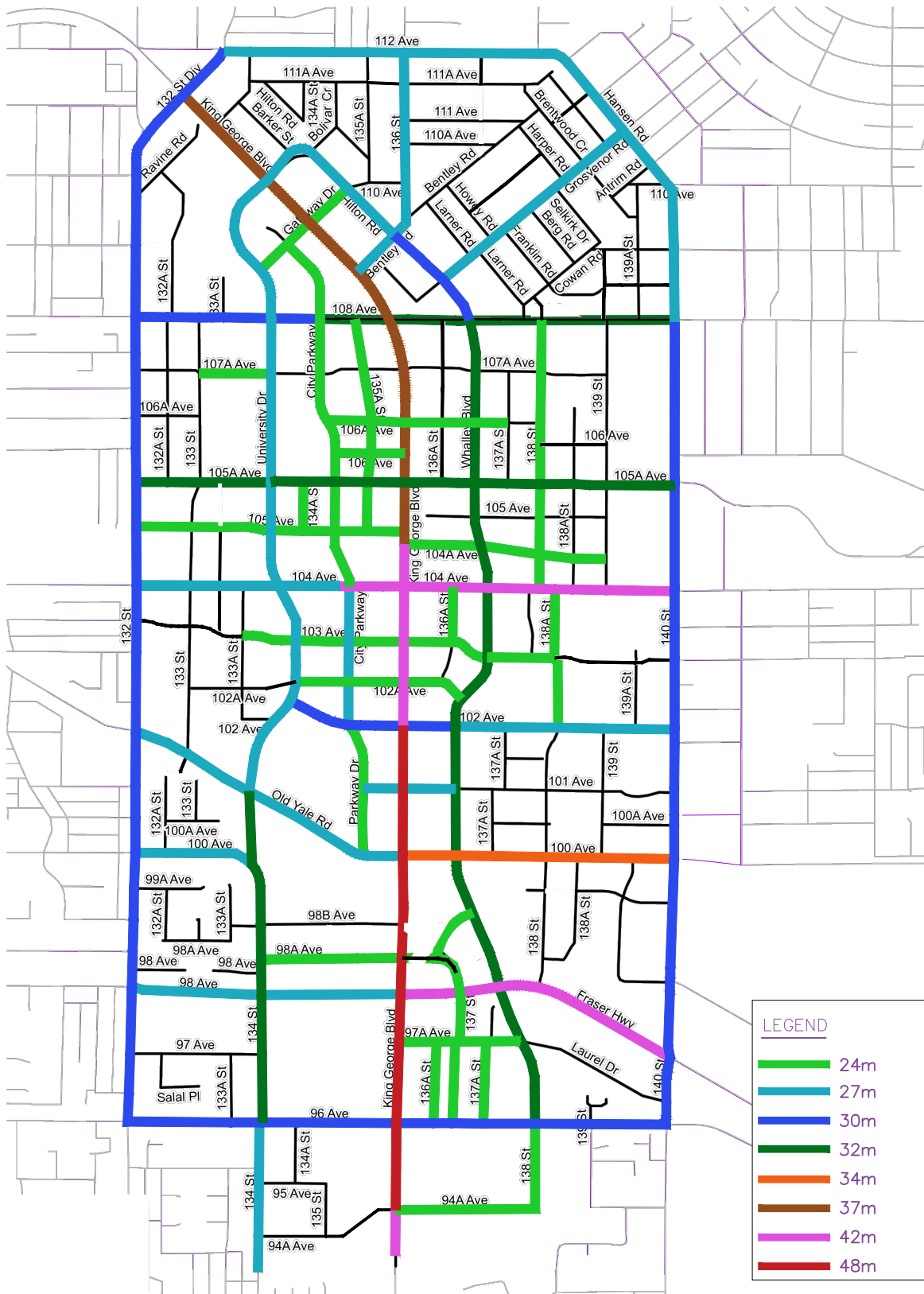

3		All Dimensions Shown In Metres, Unless Otherwise Noted	
2			
1	APRIL 2020	S. NEUMAN	Title
	Revision Date	Approved	BOUNDARY DELINEATION MAP
		CITY CENTRE STANDARD DRAWINGS Approved By : APRIL 2020	DRAWING NUMBER CCSD-1

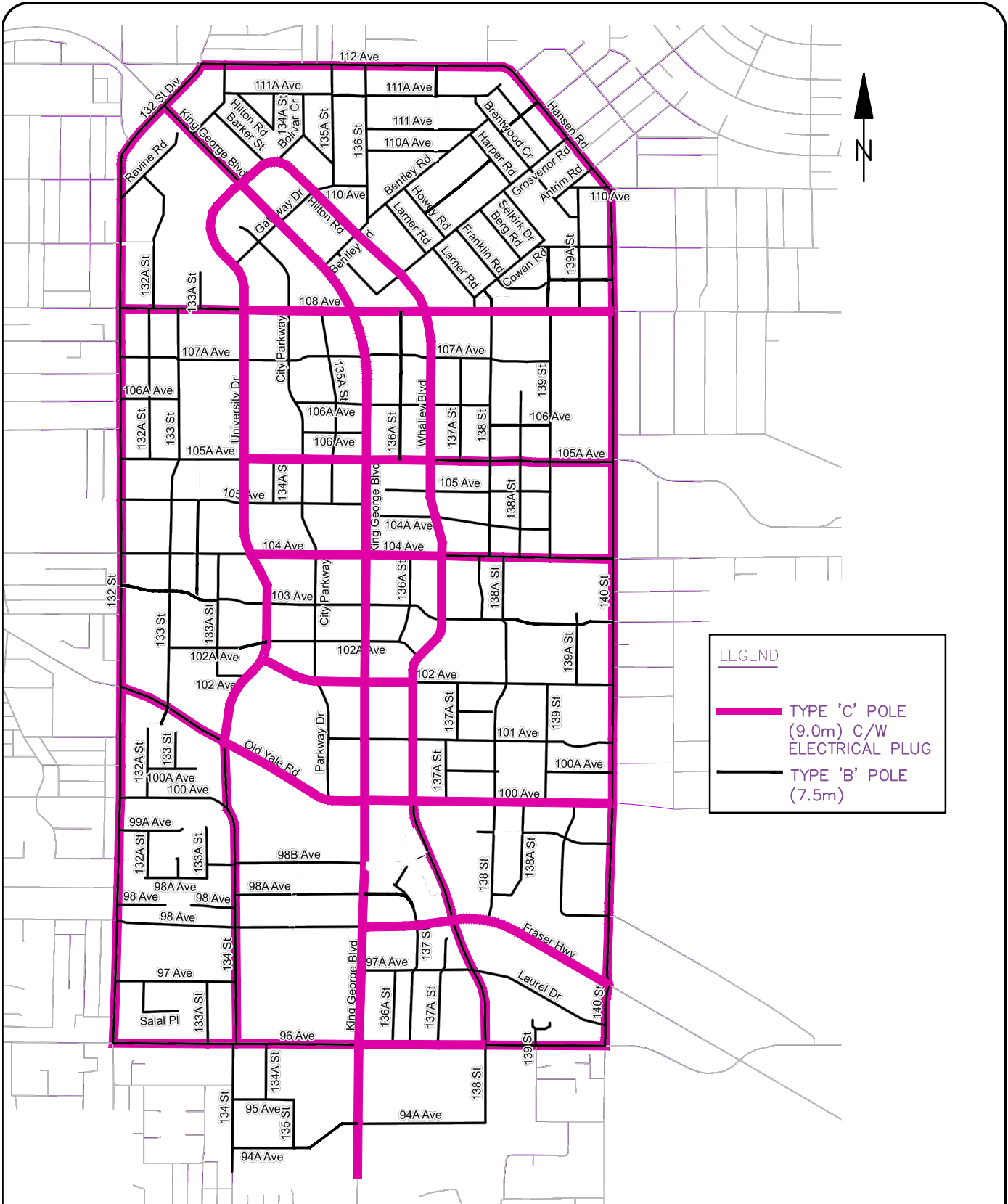

LEGEND	
	24m
	27m
	30m
	32m
	34m
	37m
	42m
	48m

3		All Dimensions Shown In Metres, Unless Otherwise Noted		
2				
1	APRIL 2020	S. NEUMAN	Title	ROAD R.O.W. WIDTH MAP
	Revision Date	Approved	Approved By :	
			APRIL 2020	G.M. Engineering
CITY CENTRE STANDARD DRAWINGS			DRAWING NUMBER	CCSD-2b



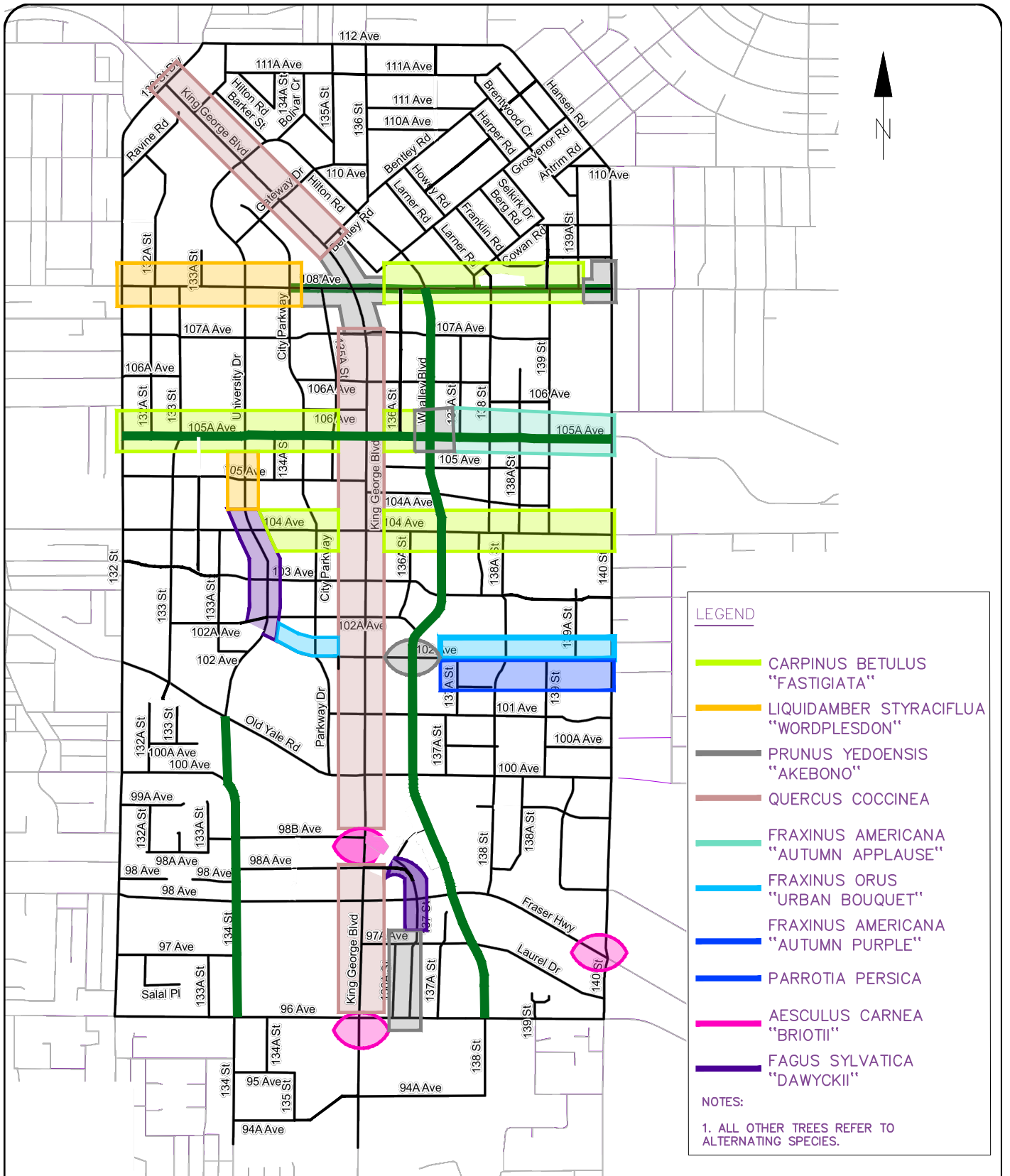

3			All Dimensions Shown In Metres, Unless Otherwise Noted
2			
1	APRIL 2020	S. NEUMAN	Title
	Revision Date	Approved	STREETLIGHT TYPE MAP
 <p>CITY OF SURREY the future lives here.</p>			Approved By :  APRIL 2020 G.M. Engineering
CITY CENTRE STANDARD DRAWINGS			DRAWING NUMBER CCSD-2c

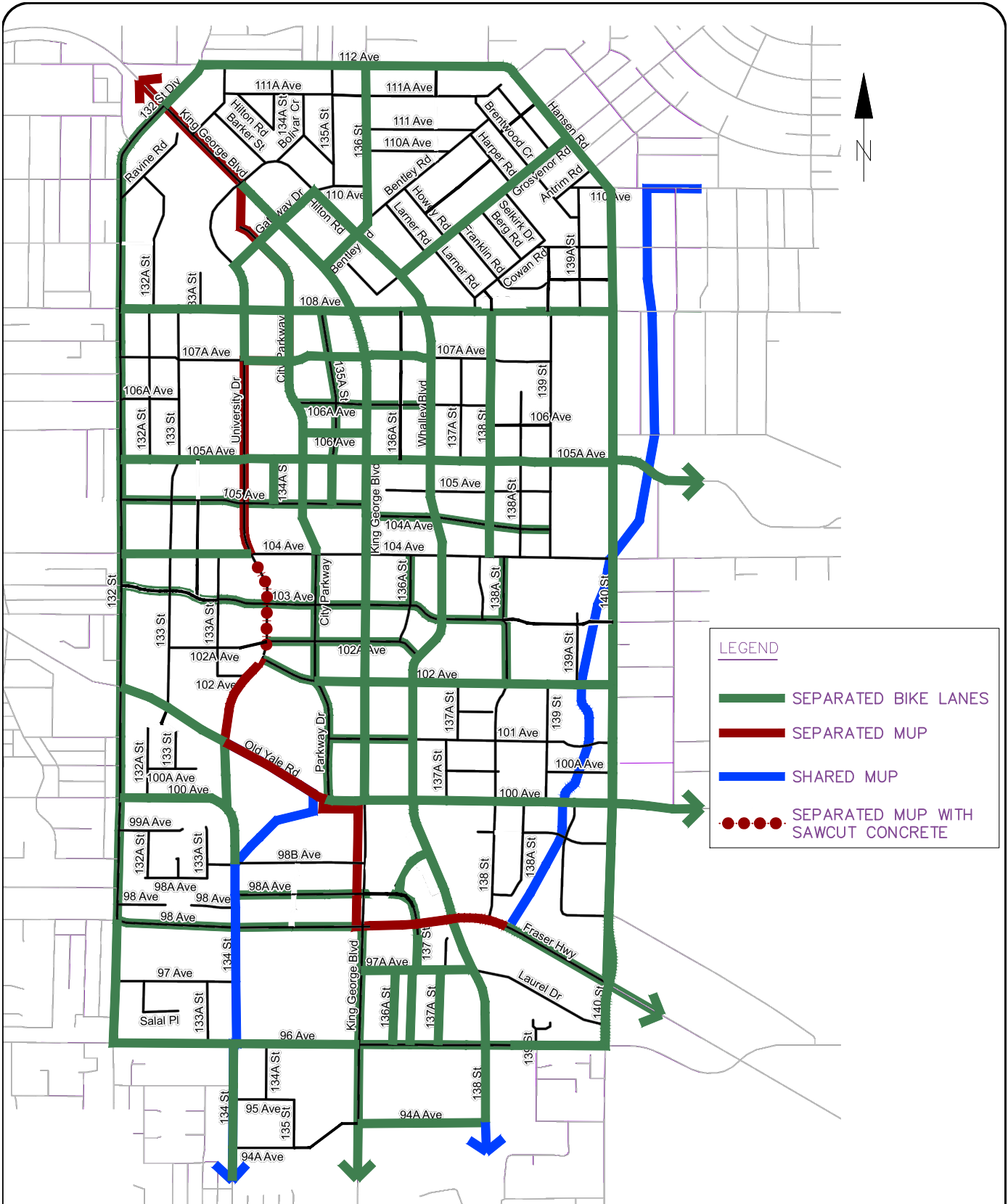

3			All Dimensions Shown In Metres, Unless Otherwise Noted
2			
1	APRIL 2020	S. NEUMAN	Title
	Revision Date	Approved	STREET – TREE TYPE MAP
			Approved By :
			 G.M. Engineering
			DRAWING NUMBER
			CCSD-3
			APRIL 2020



3			All Dimensions Shown In Metres, Unless Otherwise Noted
2			
1	APRIL 2020	S. NEUMAN	Title
	Revision Date	Approved	SEPARATED CYCLING PATHS
			Approved By :
CITY CENTRE STANDARD DRAWINGS			 G.M. Engineering
			DRAWING NUMBER CCSD-4
			APRIL 2020

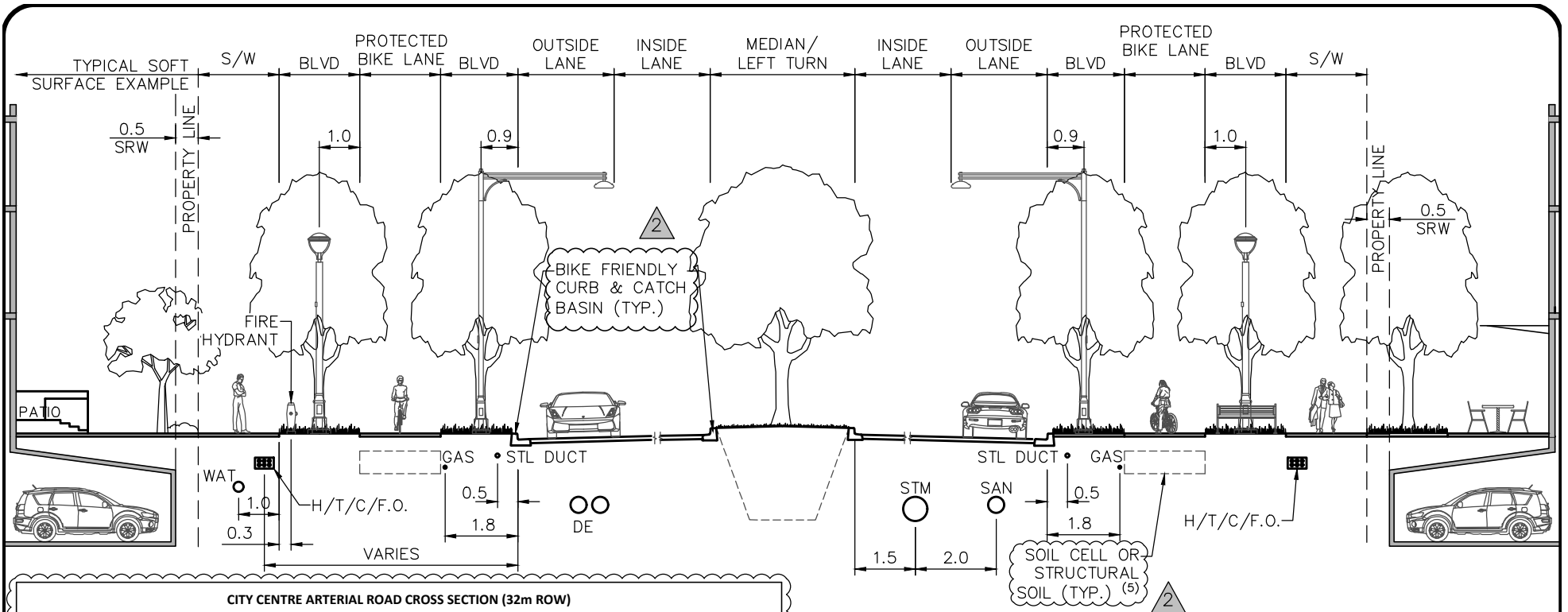

BOULEVARD SECTION

N.T.S

CITY CENTRE ARTERIAL ROAD CROSS SECTION (32m ROW)	
ELEMENTS	ACCEPTABLE RANGES* (m)
TRAVEL LANE (OUTSIDE/INSIDE)	3.1-3.3
LEFT TURN LANE	3.0-3.2
PROTECTED BIKE LANE	1.5-2.0
CURB SIDE BOULEVARD	1.5-1.9**
BOULEVARD (BETWEEN CT AND SW)	0-2.0**
SIDEWALK	1.8-2.0
* AS ACCEPTED BY THE CITY ENGINEER	
** BOULEVARD WIDTHS LESS THAN 0.7M SHALL BE CHARCOAL GREY STAMPED CONCRETE OR ASPHALT. BOULEVARD WIDTHS BETWEEN 0.7M TO 1.09M WILL BE PLANTED WITH LOW LEVEL DROUGHT TOLERANT PLANTS. BOULEVARD WIDTHS 1.1M AND GREATER WILL BE PLANTED WITH TREES	

- NOTES:
- (1) LANDSCAPED MEDIAN AS PER SSD-R16, LEFT TURN BAY AS PER SSD-R15.
 - (2) REFER TO SPECIFIC TREATMENT OPTION FOR CIVIC CENTRE, COMMERCIAL, AND RESIDENTIAL FRONTAGE.
 - (3) STRUCTURAL SOIL TO MEET SECTION 02727 SURREY PARK STANDARDS.

3		
2	APRIL 2020	S. NEUMAN
1	JULY 2017	
	Revision Date	Approved

All Dimensions Shown In Metres,
Unless Otherwise Noted

Title **TYPICAL ARTERIAL ROAD CROSS SECTION 32m ROW**

Approved By : 
APRIL 2020 G.M. Engineering

DRAWING NUMBER
CCSD-5a



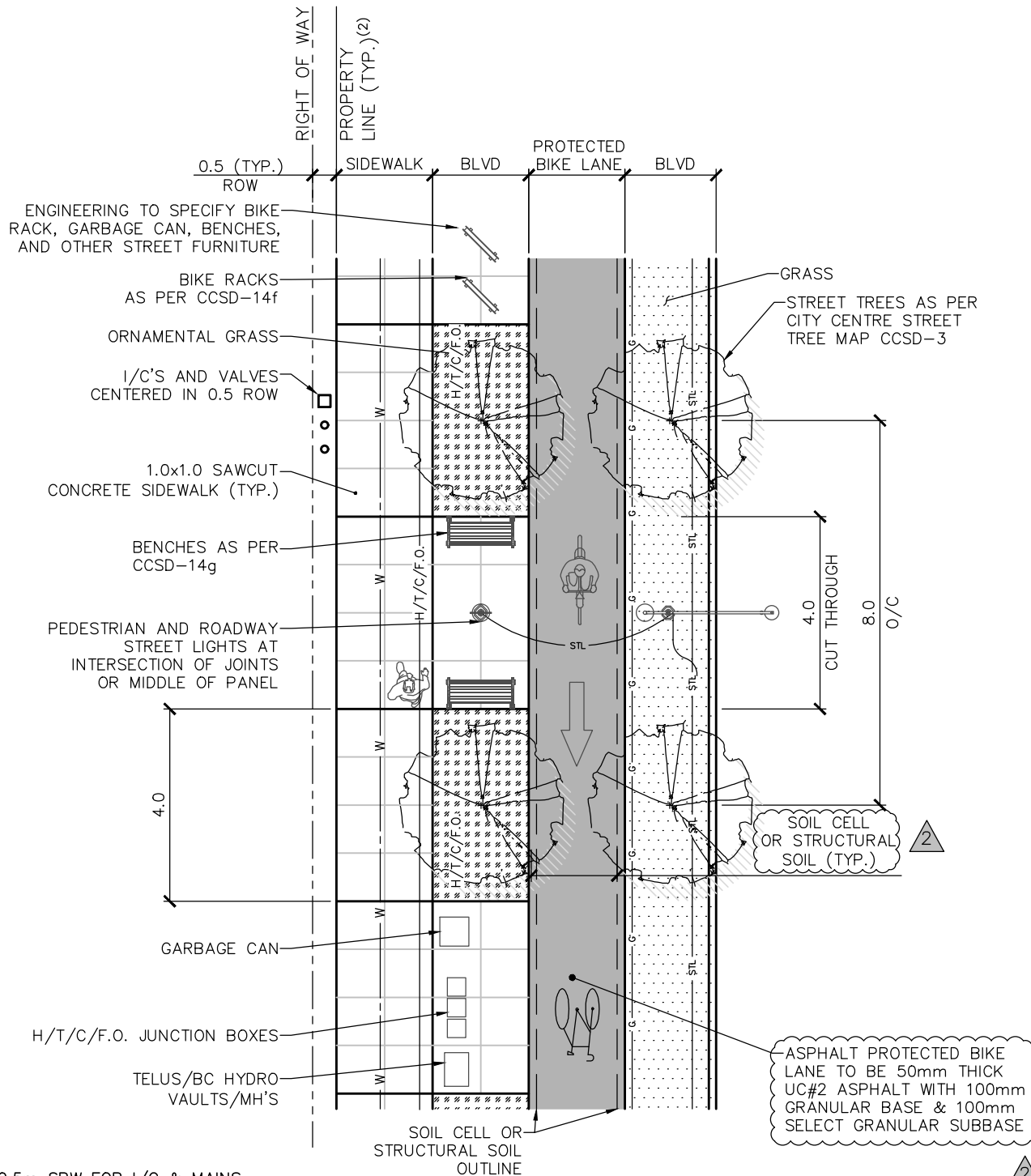

CITY CENTRE
STANDARD
DRAWINGS



NOTES:

1. 0.5m SRW FOR I/C & MAINS.
2. IF BUILDING NOT ADJACENT TO SIDEWALK, ADD ON ADDITIONAL 0.5m TO ROW.
3. STRUCTURAL SOIL TO MEET SECTION 02727 SURREY PARK STANDARDS.
4. USE REVERSE BIKE FRIENDLY CURB AND CATCH BASINS.
5. SEE CCSD-5a FOR GROSS SECTION ELEMENT WIDTHS.

3			All Dimensions Shown In Metres, Unless Otherwise Noted
2	APRIL 2020	S. NEUMAN	
1	JULY 2017		
	Revision Date	Approved	Title PROTECTED BIKE LANE PLAN VIEW 32m ROW
		CITY CENTRE STANDARD DRAWINGS	Approved By :  G.M. Engineering
			DRAWING NUMBER CCSD-5b
			APRIL 2020

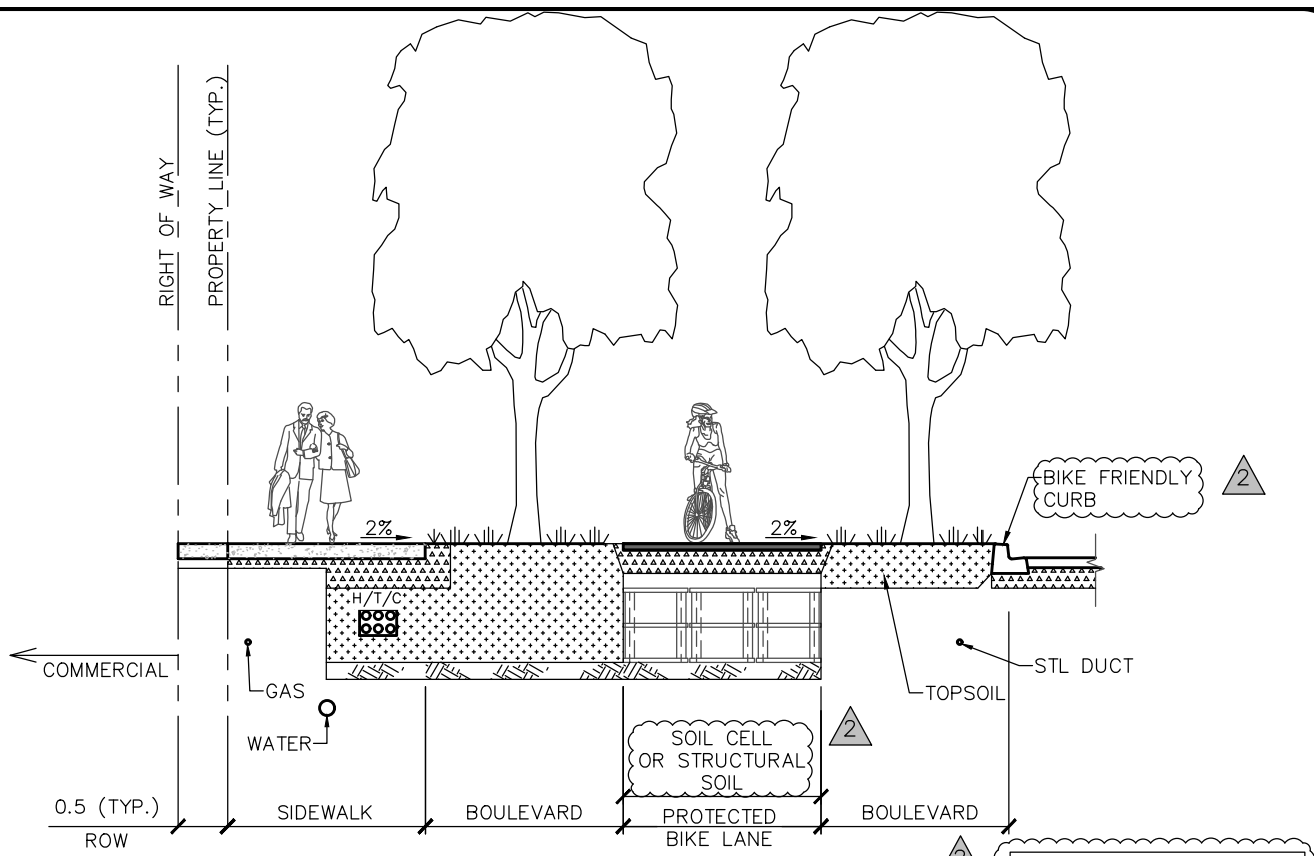

SECTION THROUGH TREE PLANTING

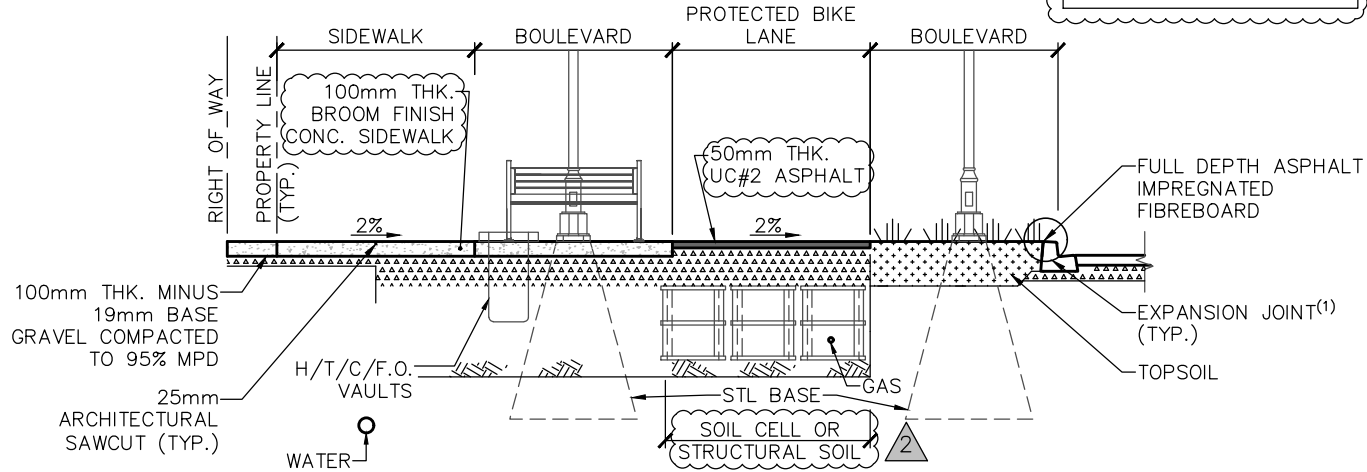

SECTION THROUGH CUT THROUGH

NOTES:

- (1) EXPANSION JOINTS SHALL USE FULL DEPTH ASPHALT IMPREGNATED FIBREBOARD @ MAXIMUM 9m LONGITUDINAL SPACING. EXPANSION JOINTS SHALL BE PROVIDED AGAINST ALL VERTICAL EDGES AND CHANGE IN MATERIALS. 50mm SMOOTH TROWEL ON BOTH SIDES OF EXPANSION JOINT.
- (2) CONTROL JOINTS SHALL HAVE A MAXIMUM 3m SPACING. CONTROL JOINTS SHALL BE SAWCUT ONLY.
- (3) CONTROL JOINT AND EXPANSION JOINT LAYOUTS TO BE CHALK MARKED AND APPROVED BY LANDSCAPE ARCHITECT PRIOR TO COMPLETION.
- (4) CONCRETE EDGE ALONG PROPERTY LINE TO HAVE 150mm TROWEL FINISH. ALL SCORELINES TO STOP PRIOR TO TROWELED EDGE.
- (5) INSTALL SOIL CELL AS PER MANUFACTURER'S RECOMMENDATIONS. ALTERNATIVELY STRUCTURAL SOIL CAN BE USED.

3			All Dimensions Shown In Metres, Unless Otherwise Noted
2	APRIL 2020	S. NEUMAN	
1	JULY 2017		Title PROTECTED BIKE LANE CROSS SECTION 32m ROW
	Revision Date	Approved	
CITY OF SURREY the future lives here.			Approved By : APRIL 2020 G.M. Engineering
			DRAWING NUMBER CCSD-5c

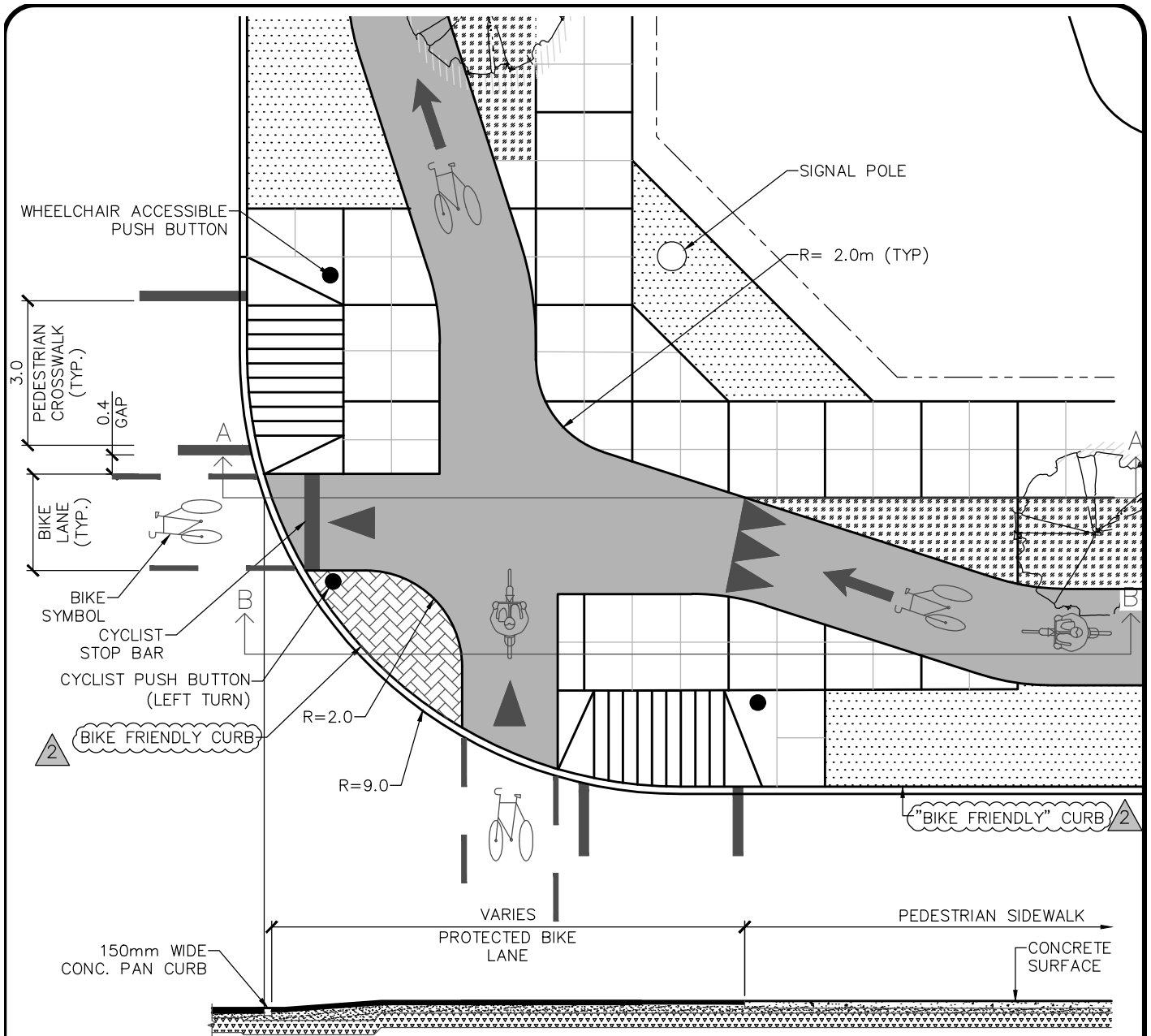

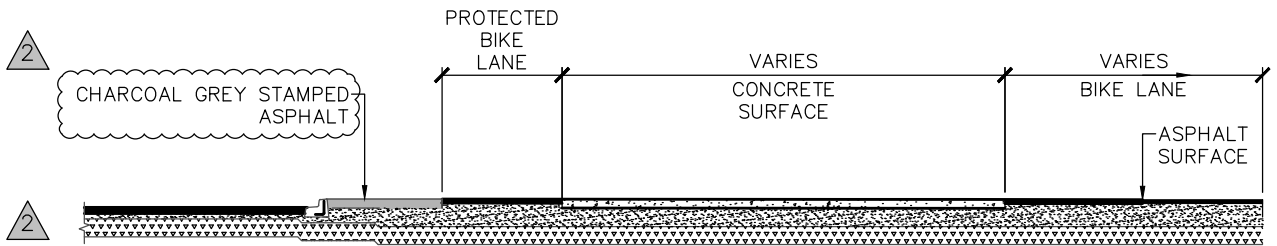

SECTION A



SECTION B

NOTE:
SEE CCSD-5a FOR CROSS SECTION ELEMENT WIDTHS.

3			All Dimensions Shown In Metres, Unless Otherwise Noted
2	APRIL 2020	S. NEUMAN	
1	JULY 2017		
	Revision Date	Approved	Title PROTECTED BIKE LANE INTERSECTION PLAN VIEW - 32m ROW
 <p>CITY OF SURREY the future lives here.</p>			Approved By :  APRIL 2020 G.M. Engineering
			DRAWING NUMBER CCSD-5d

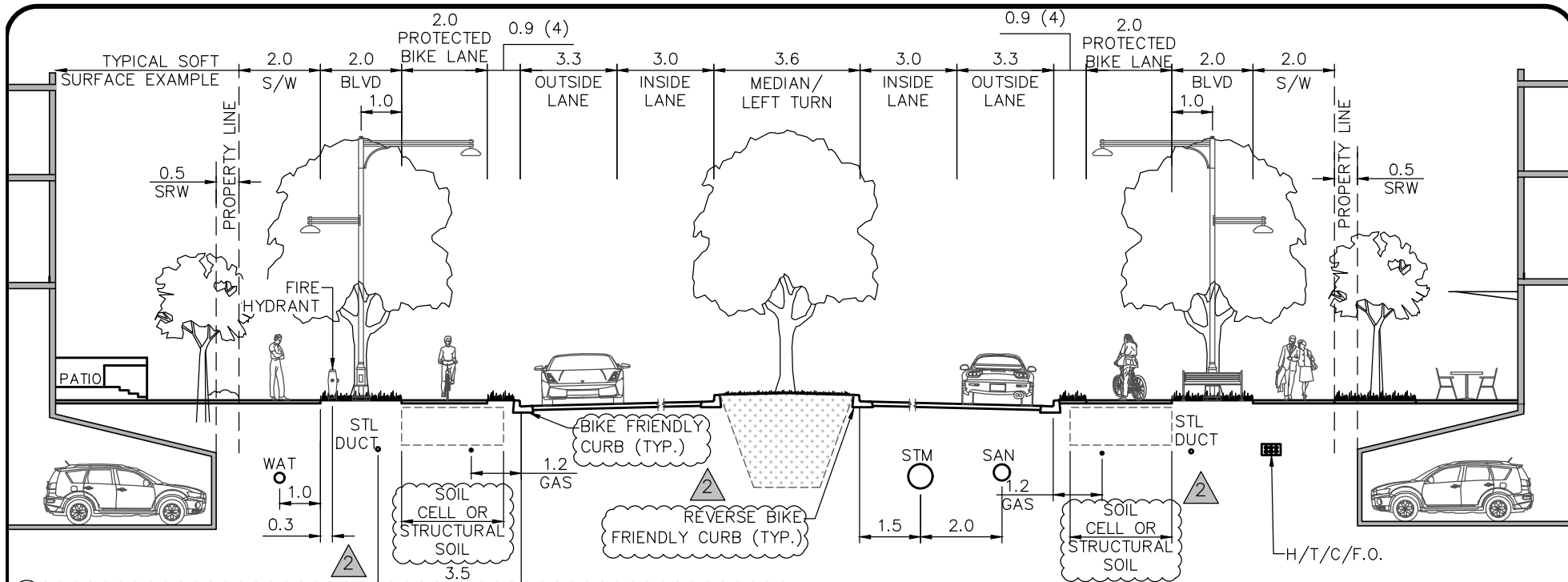

CITY CENTRE ARTERIAL ROAD CROSS SECTION (30m ROW)

ELEMENTS	ACCEPTABLE RANGES* (m)
TRAVEL LANE (OUTSIDE/INSIDE)	3.1-3.3
LEFT TURN LANE	3.0-3.2
PROTECTED BIKE LANE	1.5-2.0
CURB SIDE BOULEVARD	0.9-1.2**
BOULEVARD (BETWEEN CT AND SW)	0-2.0**
SIDEWALK	1.8-2.0

* AS ACCEPTED BY THE CITY ENGINEER

** BOULEVARD WIDTHS LESS THAN 0.7M SHALL BE CHARCOAL GREY STAMPED CONCRETE OR ASPHALT. BOULEVARD WIDTHS BETWEEN 0.7M TO 1.09M WILL BE PLANTED WITH LOW LEVEL DROUGHT TOLERANT PLANTS. BOULEVARD WIDTHS 1.1M AND GREATER WILL BE PLANTED WITH TREES

BOULEVARD SECTION

N.T.S

NOTES:

- (1) LANDSCAPED MEDIAN AS PER SSD-R16, LEFT TURN BAY AS PER SSD-R15.
- (2) REFER TO SPECIFIC TREATMENT OPTION FOR CIVIC CENTRE, COMMERCIAL, AND RESIDENTIAL FRONTAGE.
- (3) DISTRICT ENERGY UTILITY LOCATION TO BE CONFIRMED BY ENGINEERING.
- (4) PLANTED SEPARATION BETWEEN TRAVEL LANES AND PROTECTED BIKE LANE
- (5) STRUCTURAL SOIL TO MEET SECTION 02727 SURREY PARK STANDARDS.



3		
2	APRIL 2020	S. NEUMAN
1	JULY 2017	
	Revision Date	Approved

All Dimensions Shown In Metres,
Unless Otherwise Noted

Title **TYPICAL ARTERIAL ROAD CROSS SECTION (30m) ROW**

Approved By :

APRIL 2020

G.M. Engineering

DRAWING NUMBER

CCSD-6a



CITY CENTRE
STANDARD
DRAWINGS

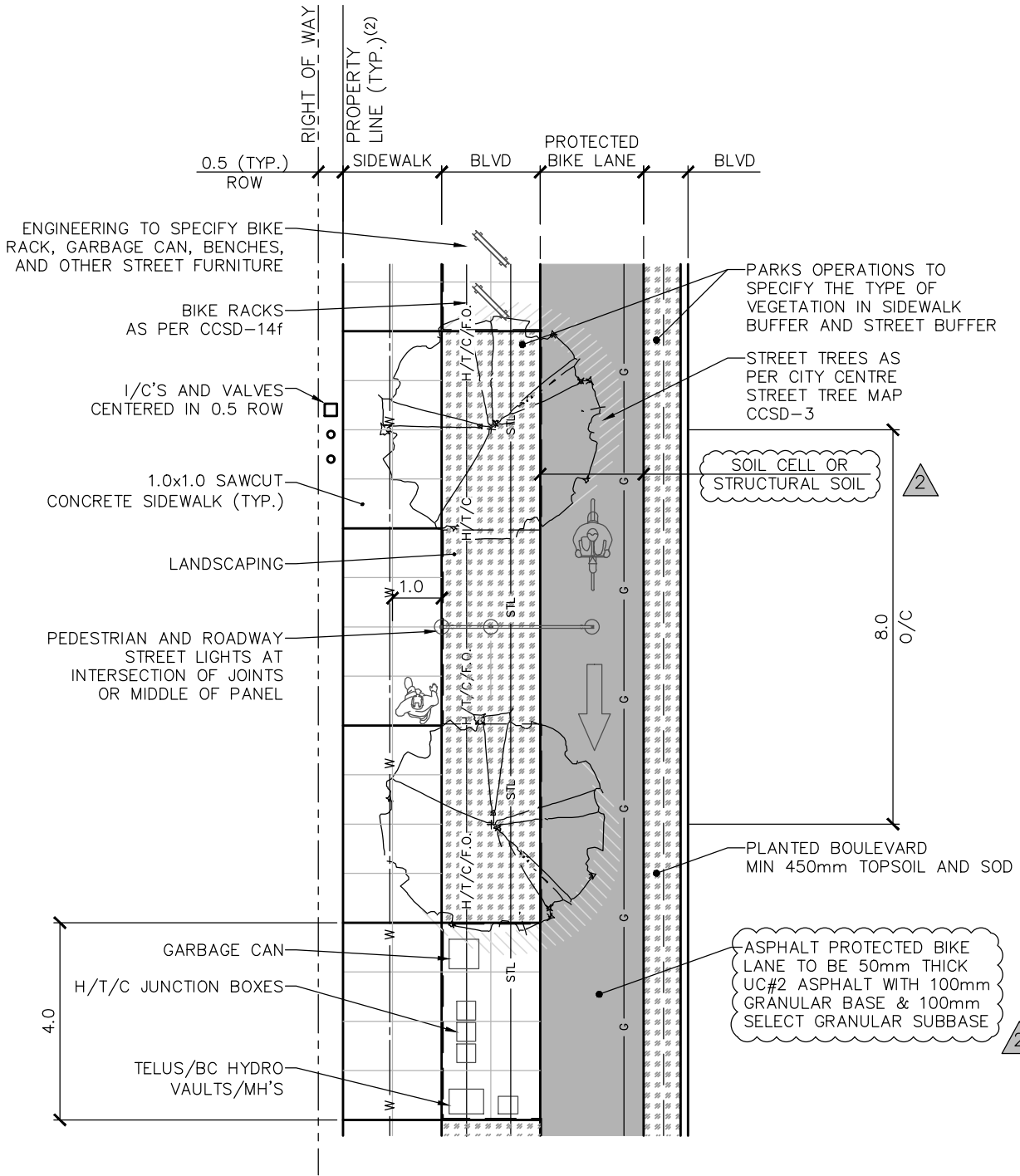

NOTES:

- (1) 0.5m SRW FOR I/C & MAINS.
- (2) IF BUILDING NOT ADJACENT TO SIDEWALK, ADD ON ADDITIONAL 0.5m TO ROW.
- (3) STRUCTURAL SOIL TO MEET SECTION 02727 SURREY PARK STANDARDS.
- (4) SEE CCSD-6a FOR CROSS SECTION ELEMENT WIDTHS.

3			All Dimensions Shown In Metres, Unless Otherwise Noted
2	APRIL 2020	S. NEUMAN	
1	JULY 2017		Title
	Revision Date	Approved	PROTECTED BIKE LANE PLAN VIEW (30m) ROW
CITY OF SURREY the future lives here.			Approved By : MARCH 2020
			DRAWING NUMBER CCSD-6b

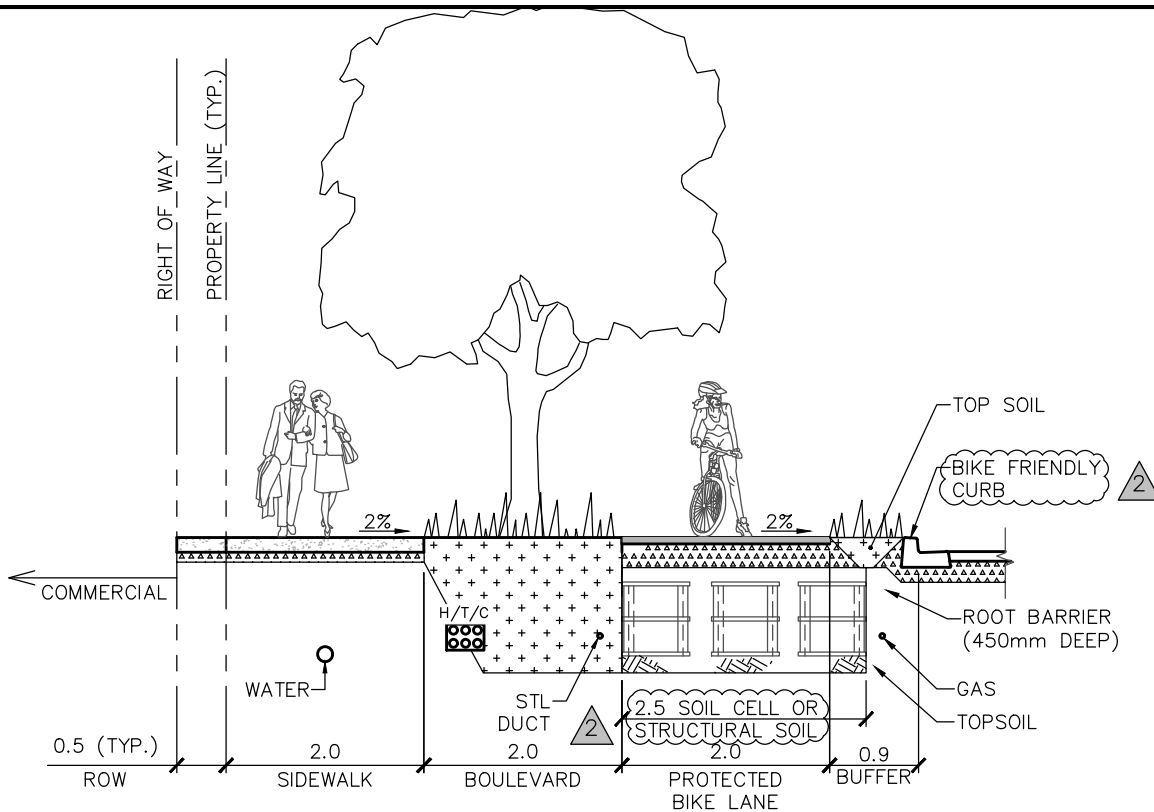

SECTION THROUGH TREE PLANTING

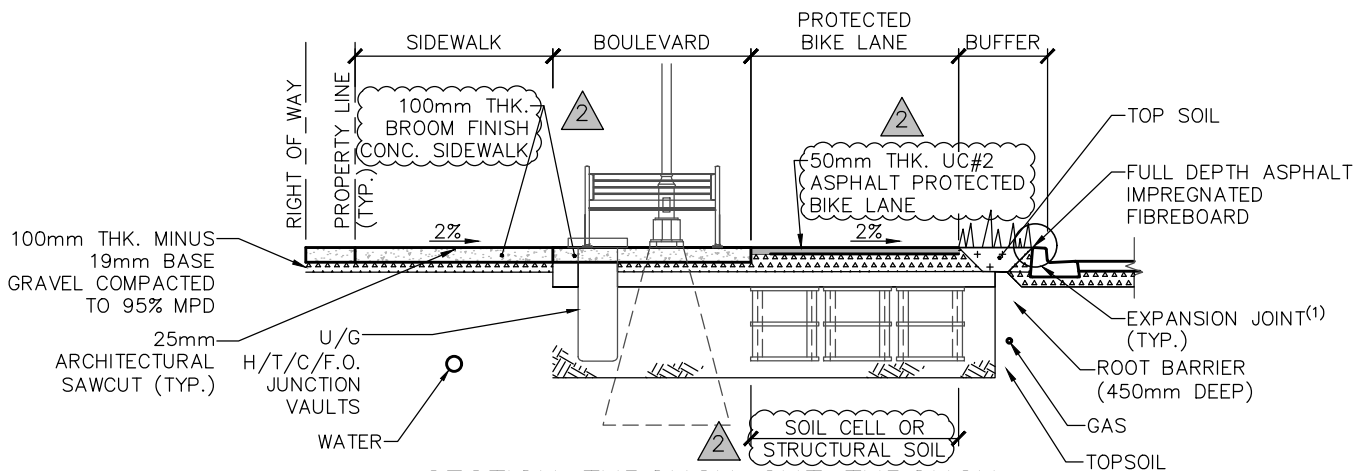

SECTION THROUGH CUT THROUGH

NOTES:

- (1) EXPANSION JOINTS SHALL USE FULL DEPTH ASPHALT IMPREGNATED FIBREBOARD @ MAXIMUM 9m LONGITUDINAL SPACING. EXPANSION JOINTS SHALL BE PROVIDED AGAINST ALL VERTICAL EDGES AND CHANGE IN MATERIALS. 50mm SMOOTH TROWEL ON BOTH SIDES OF EXPANSION JOINT.
- (2) CONTROL JOINTS SHALL HAVE A MAXIMUM 3m SPACING. CONTROL JOINTS SHALL BE SAWCUT ONLY.
- (3) CONTROL JOINT AND EXPANSION JOINT LAYOUTS TO BE CHALK MARKED AND APPROVED BY LANDSCAPE ARCHITECT PRIOR TO COMPLETION.
- (4) CONCRETE EDGE ALONG PROPERTY LINE TO HAVE 150mm TROWEL FINISH. ALL SCORELINES TO STOP PRIOR TO TROWELED EDGE.
- (5) INSTALL SOIL CELL AS PER MANUFACTURER'S RECOMMENDATIONS. ALTERNATIVELY, STRUCTURAL SOIL CAN BE USED.

3			All Dimensions Shown In Metres, Unless Otherwise Noted
2	APRIL 2020	S. NEUMAN	
1	JULY 2017		
	Revision Date	Approved	Title PROTECTED BIKE LANE CROSS SECTION (30m) ROW
			Approved By : APRIL 2020 G.M. Engineering
			DRAWING NUMBER CCSD-6c

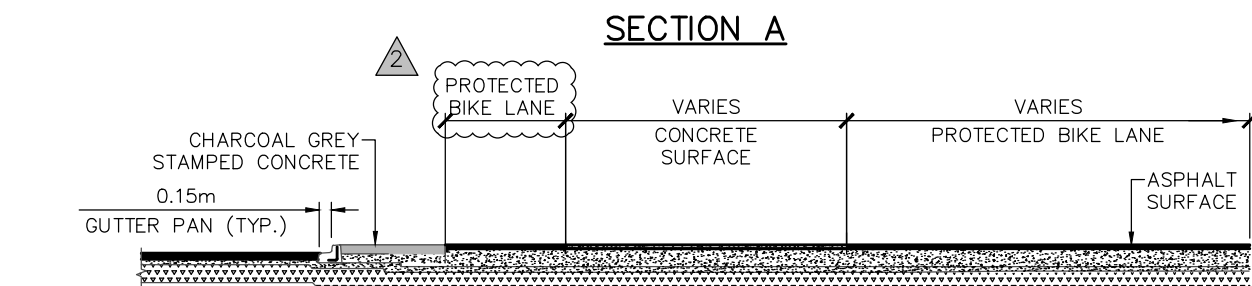
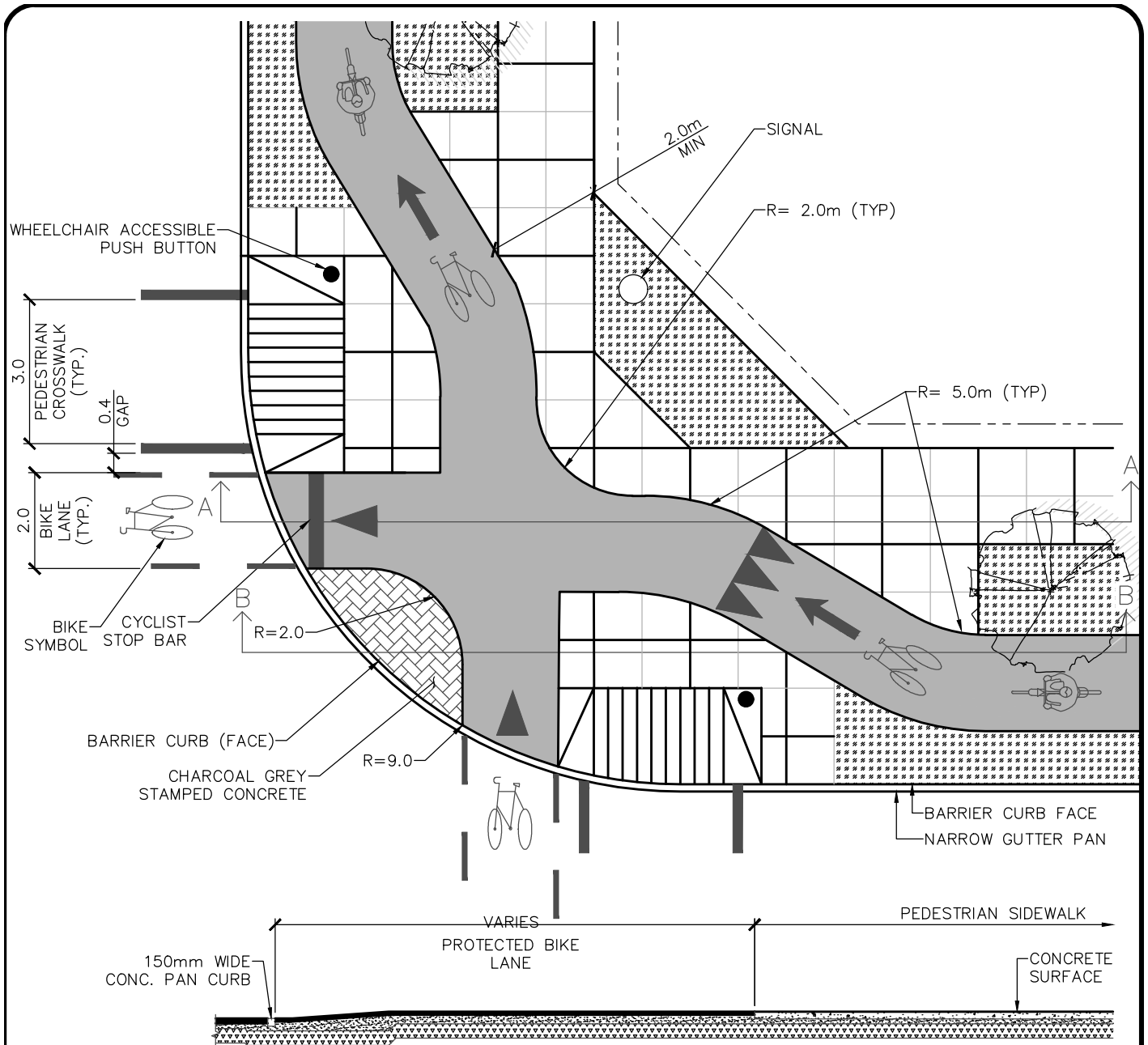

3			All Dimensions Shown In Metres, Unless Otherwise Noted
2			
1	APRIL 2020	S. NEUMAN	Title PROTECTED BIKE LANE INTERSECTION PLAN (30m) ROW
	Revision Date	Approved	
			Approved By : MARCH 2020 G.M. Engineering
CITY CENTRE STANDARD DRAWINGS			DRAWING NUMBER CCSD-6d

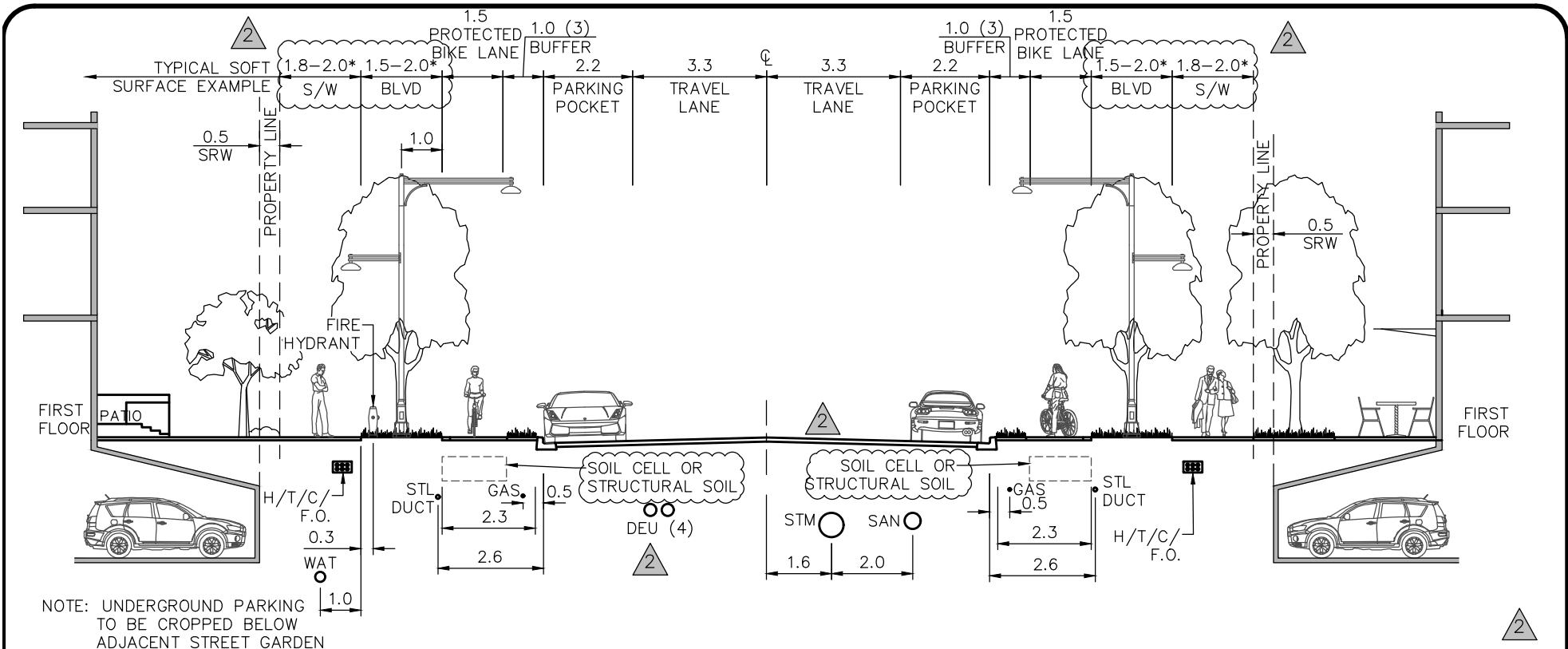

BOULEVARD SECTION
N.T.S

* AS ACCEPTED BY THE CITY ENGINEER.

- NOTES:
- (1) LANDSCAPED MEDIAN AS PER SSD-R16, LEFT TURN BAY AS PER SSD-R15.
 - (2) REFER TO SPECIFIC TREATMENT OPTION FOR CIVIC CENTRE, COMMERCIAL, AND RESIDENTIAL FRONTAGE.
 - (3) BUFFER SEPARATION BETWEEN TRAVEL LANES AND PROTECTED BIKE LANE.
 - (4) DISTRICT ENERGY UTILITY LOCATION TO BE CONFIRMED BY ENGINEERING.

3		
2	APRIL 2020	S. NEUMAN
1	JULY 2017	
	Revision Date	Approved

CITY CENTRE STANDARD DRAWINGS

All Dimensions Shown In Metres,
Unless Otherwise Noted

Title **TYPICAL COLLECTOR ROAD
CROSS SECTION (24m) ROW**

Approved By :

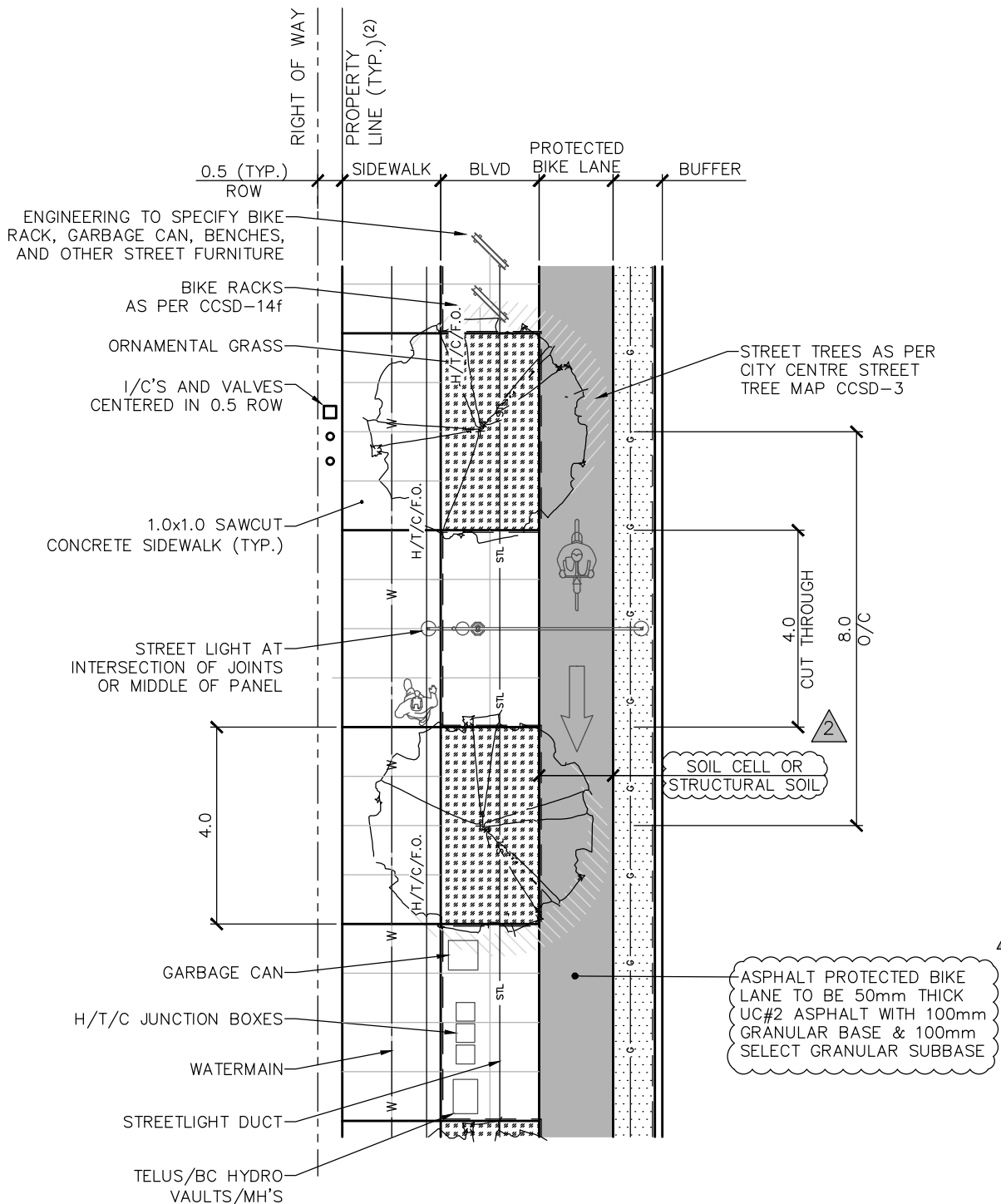

APRIL 2020 G.M. Engineering

DRAWING NUMBER
CCSD-7a



NOTES:

- (1) 0.5m SRW FOR I/C & MAINS.
- (2) IF BUILDING NOT ADJACENT TO SIDEWALK, ADD ON ADDITIONAL 0.5m TO ROW
- (3) SEE CCSD-7a FOR CROSS SECTION ELEMENT WIDTHS.

3			All Dimensions Shown In Metres, Unless Otherwise Noted
2			
1	APRIL 2020	S. NEUMAN	Title
	Revision Date	Approved	PROTECTED BIKE LANE PLAN VIEW (24m) ROW
 <p>CITY OF SURREY the future lives here.</p>			Approved By :  APRIL 2020 G.M. Engineering
CITY CENTRE STANDARD DRAWINGS			DRAWING NUMBER CCSD-7b

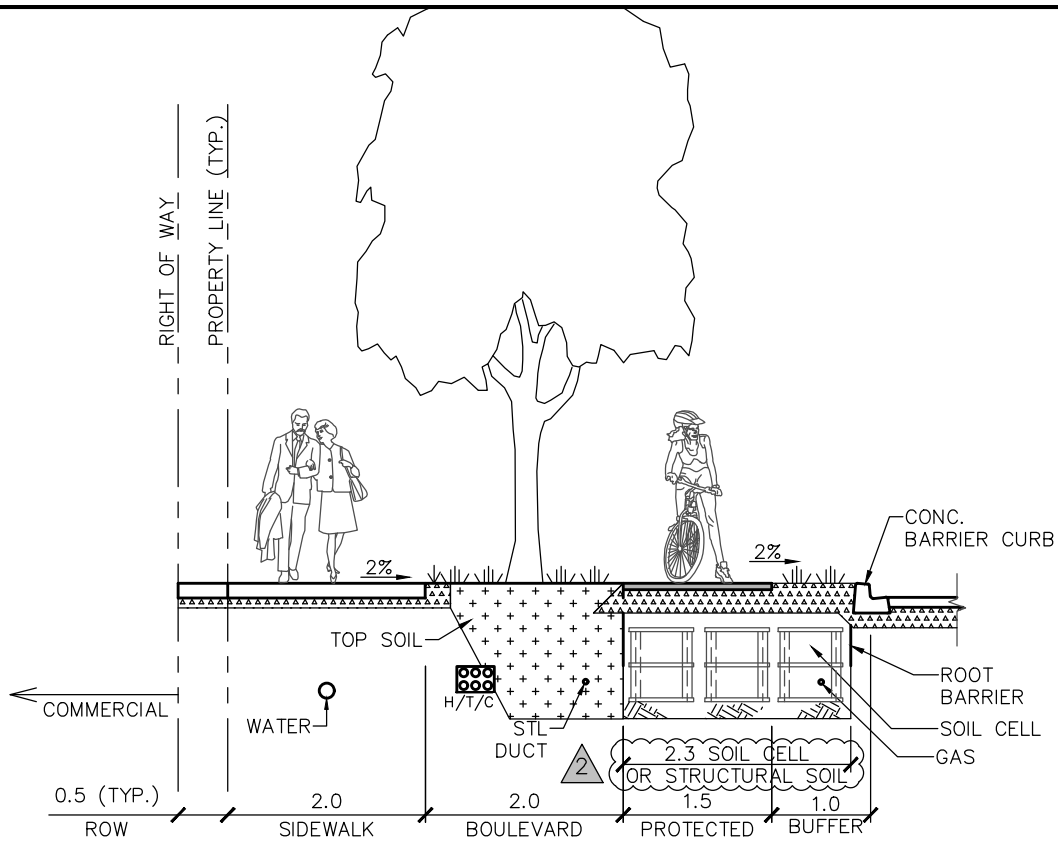

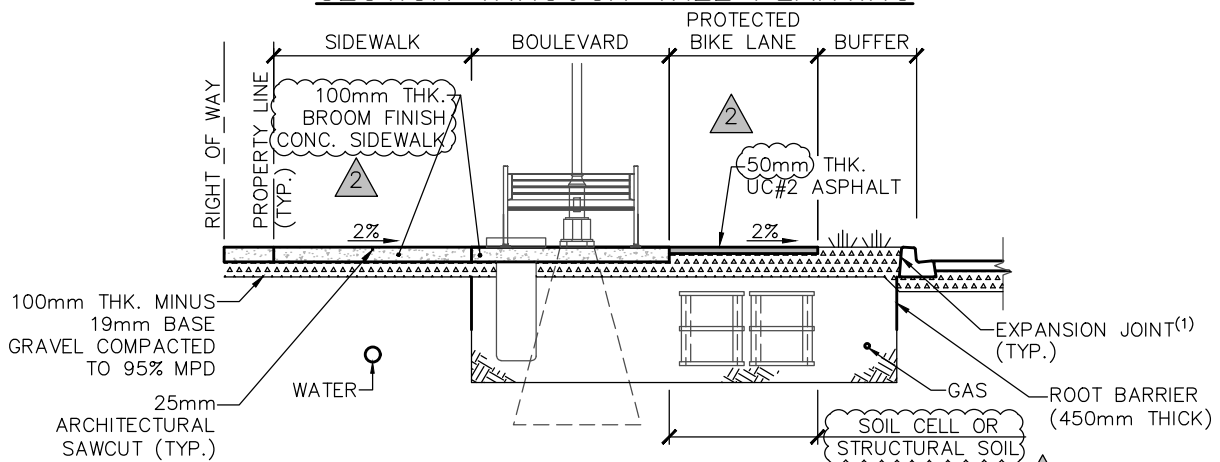

SECTION THROUGH TREE PLANTING



SECTION THROUGH CUT THROUGH

NOTES:

- (1) EXPANSION JOINTS SHALL USE FULL DEPTH ASPHALT IMPREGNATED FIBREBOARD @ MAXIMUM 9m LONGITUDINAL SPACING. EXPANSION JOINTS SHALL BE PROVIDED AGAINST ALL VERTICAL EDGES AND CHANGE IN MATERIALS. 50mm SMOOTH TROWEL ON BOTH SIDES OF EXPANSION JOINT.
- (2) CONTROL JOINTS SHALL HAVE A MAXIMUM 3m SPACING. CONTROL JOINTS SHALL BE SAWCUT ONLY.
- (3) CONTROL JOINT AND EXPANSION JOINT LAYOUTS TO BE CHALK MARKED AND APPROVED BY LANDSCAPE ARCHITECT PRIOR TO COMPLETION.
- (4) CONCRETE EDGE ALONG PROPERTY LINE TO HAVE 150mm TROWEL FINISH. ALL SCORELINES TO STOP PRIOR TO TROWELED EDGE.
- (5) INSTALL SOIL CELL AS PER MANUFACTURER'S RECOMMENDATIONS. ALTERNATIVELY STRUCTURAL SOIL CAN BE USED.

3			All Dimensions Shown In Metres, Unless Otherwise Noted
2	APRIL 2020	S. NEUMAN	
1	JULY 2017		Title PROTECTED BIKE LANE CROSS SECTION (24m) ROW
	Revision Date	Approved	
			Approved By :  APRIL 2020 G.M. Engineering
CITY CENTRE STANDARD DRAWINGS			DRAWING NUMBER CCSD-7c

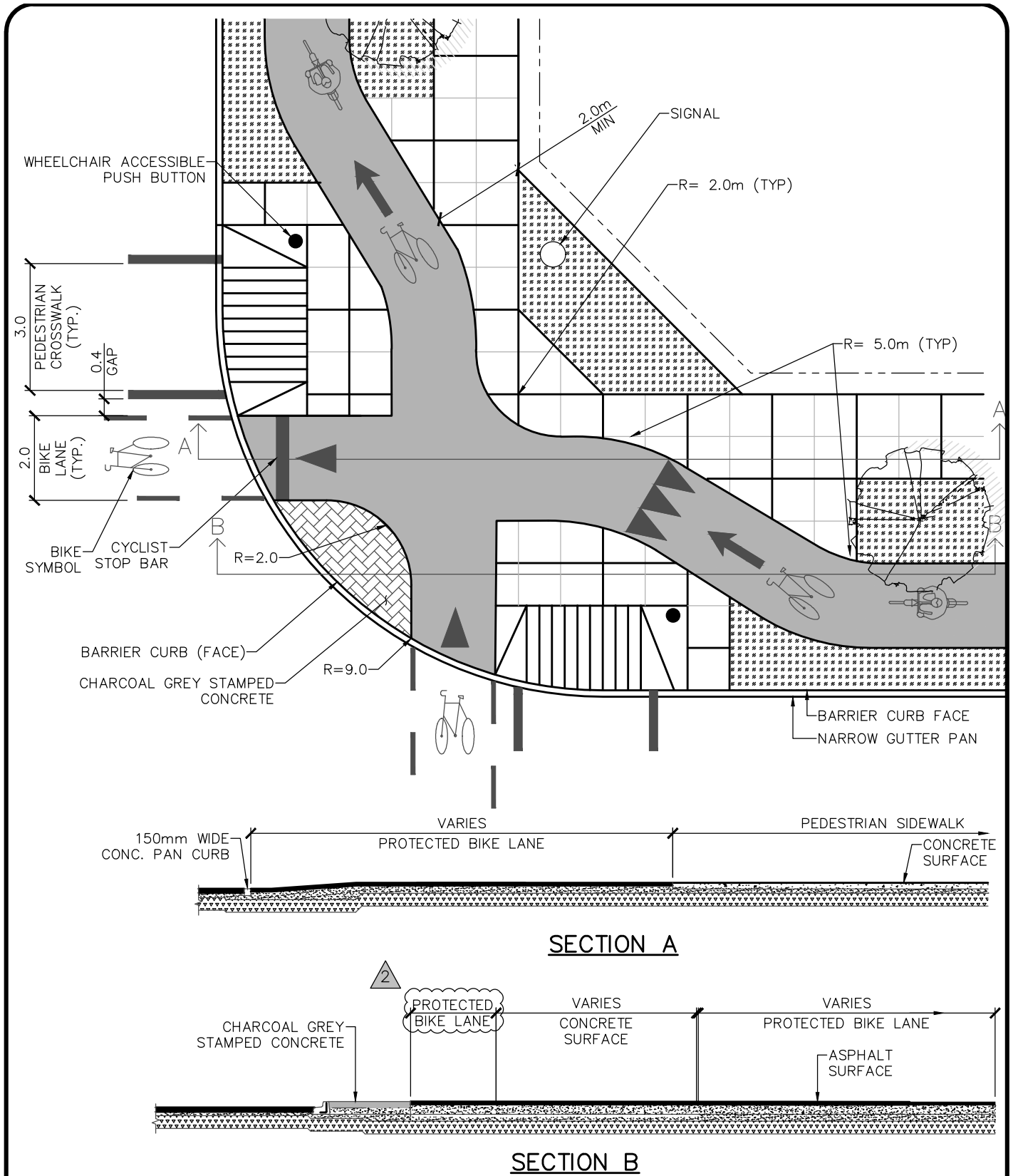

3				All Dimensions Shown In Metres, Unless Otherwise Noted	
2					
1	APRIL 2020	S. NEUMAN	Title	PROTECTED BIKE LANE INTERSECTION PLAN VIEW (24m) ROW	
	Revision Date	Approved	Approved By :		
CITY OF SURREY the future lives here.			CITY CENTRE STANDARD DRAWINGS	Approved By : APRIL 2020 G.M. Engineering	DRAWING NUMBER CCSD-7d

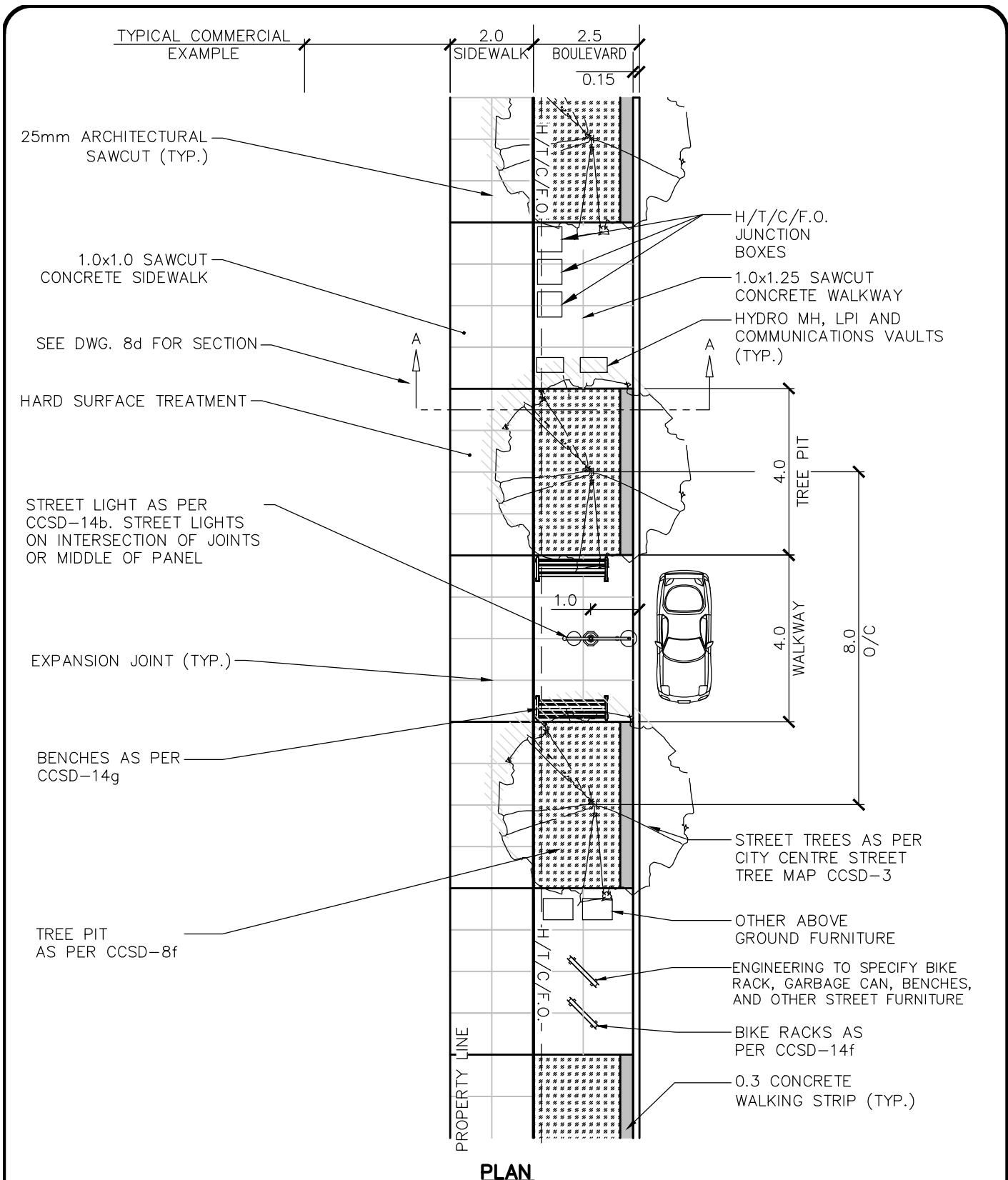

PLAN

3		
2		
1	APRIL 2020	S. NEUMAN
	Revision Date	Approved

All Dimensions Shown In Metres,
Unless Otherwise Noted

Title **LOCAL BOULEVARD FOR 20M ROW
HARDSCAPE FRONTAGE**

CITY OF SURREY
the future lives here.

CITY CENTRE
STANDARD
DRAWINGS

Approved By : *[Signature]*
APRIL 2020 G.M. Engineering

DRAWING NUMBER
CCSD-8b

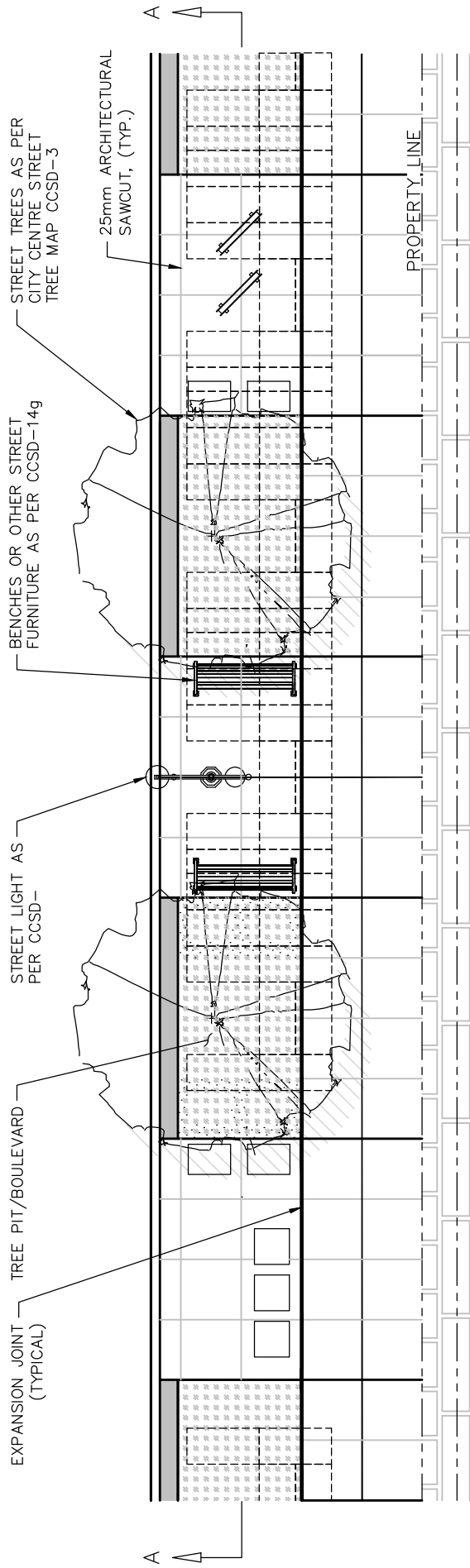

PLAN

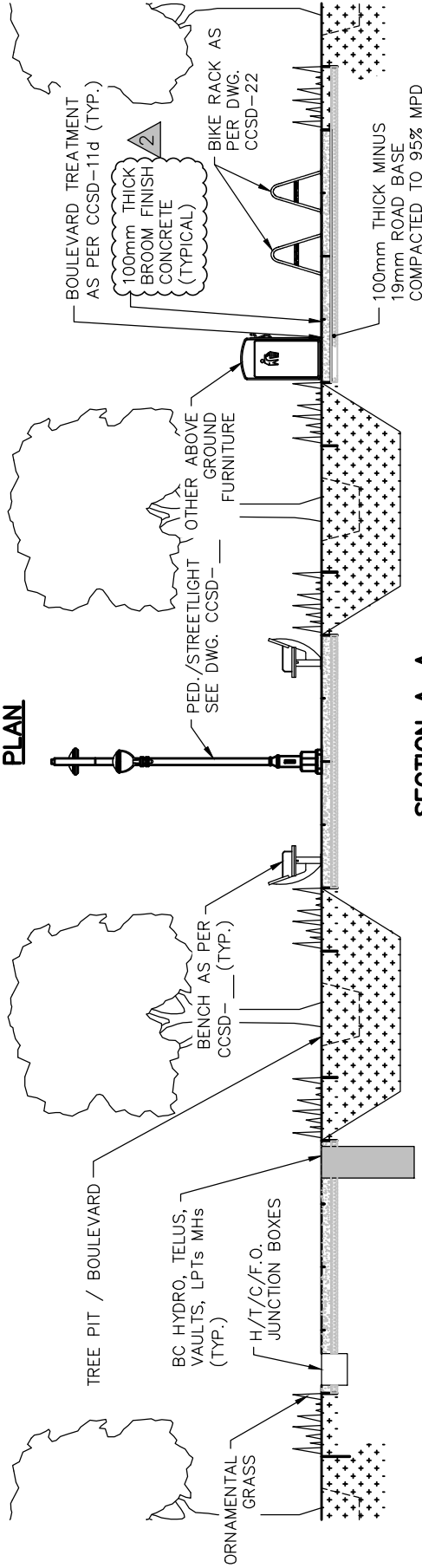

SECTION A-A

All Dimensions Shown in Metres,
Unless Otherwise Noted

3		
2	APRIL 2020	S. NEUMAN
1	JULY 2017	Approved
	Revision Date	Approved

Title **LOCAL BOULEVARD FOR 20m ROW
BLVD TREATMENT PLAN & SECTION**

Approved By :

DRAWING NUMBER
CCSD-8C

APRIL 2020 G.M. Engineering

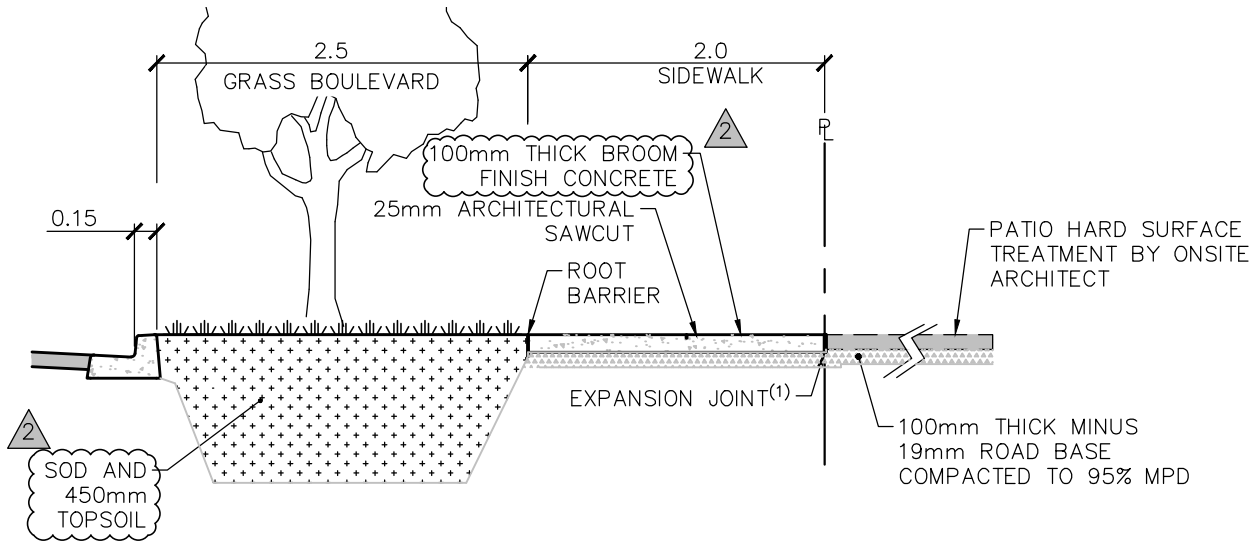
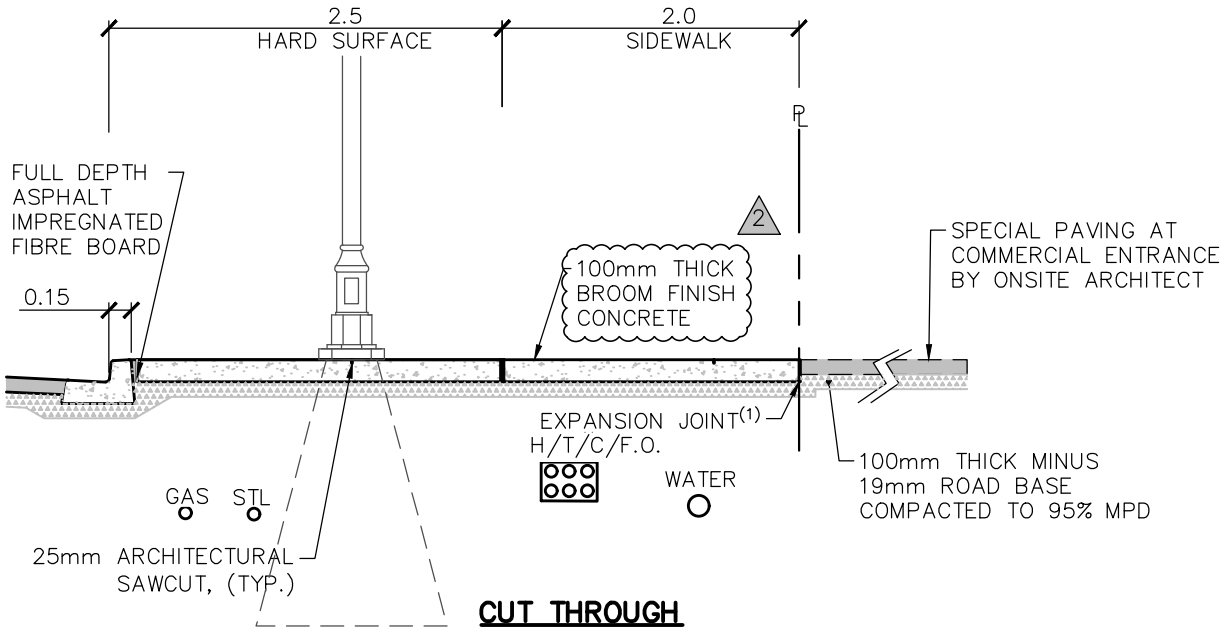

CITY OF SURREY
the future lives here.

CITY CENTRE
STANDARD
DRAWINGS



- NOTES:
- (1) EXPANSION JOINTS SHALL USE FULL DEPTH ASPHALT IMPREGNATED FIBREBOARD @ MAXIMUM 9m LONGITUDINAL SPACING. EXPANSION JOINTS SHALL BE PROVIDED AGAINST ALL VERTICAL EDGES AND CHANGE IN MATERIALS. 50mm SMOOTH TROWEL ON BOTH SIDES OF EXPANSION JOINT.
 - (2) CONTROL JOINTS SHALL HAVE A MAXIMUM 3m SPACING. CONTROL JOINTS SHALL BE SAWCUT ONLY.
 - (3) CONTROL JOINT AND EXPANSION JOINT LAYOUTS TO BE CHALK MARKED AND APPROVED BY LANDSCAPE ARCHITECT PRIOR TO COMPLETION.



(4) INSTALL SOIL CELL OR STRUCTURAL SOIL AS PER MANUFACTURER'S RECOMMENDATION. ALTERNATIVELY STRUCTURAL SOIL CAN BE USED.

3			All Dimensions Shown In Metres, Unless Otherwise Noted
2	APRIL 2020	S. NEUMAN	
1	JULY 2017		
	Revision Date	Approved	Title LOCAL BOULEVARD FOR 20m ROW TYPICAL HARDSCAPE SECTION (4.5m) BLVD
 <p>CITY OF SURREY the future lives here.</p>			Approved By :  APRIL 2020 G.M. Engineering
CITY CENTRE STANDARD DRAWINGS			DRAWING NUMBER CCSD-8d

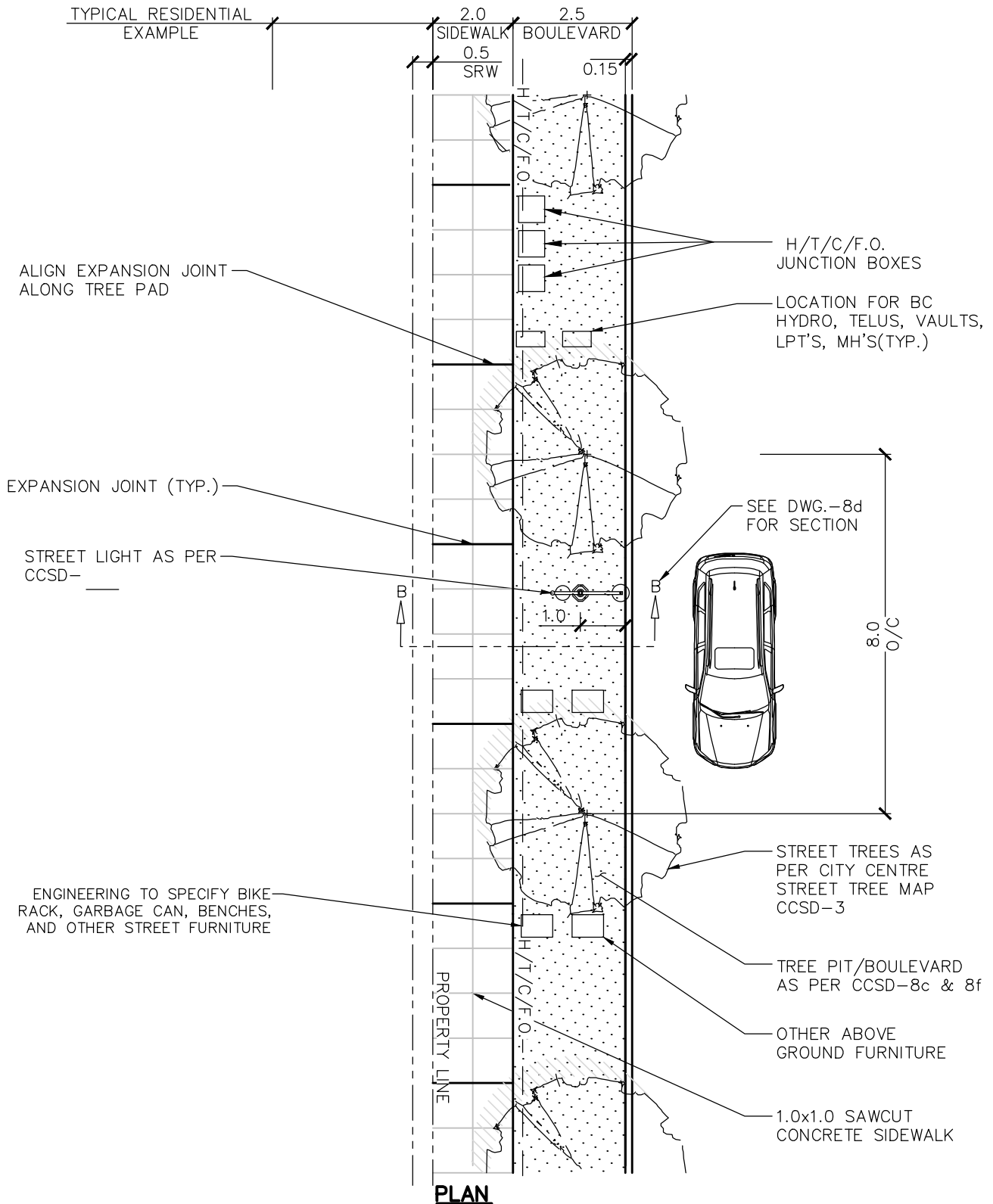
TYPICAL RESIDENTIAL
EXAMPLE



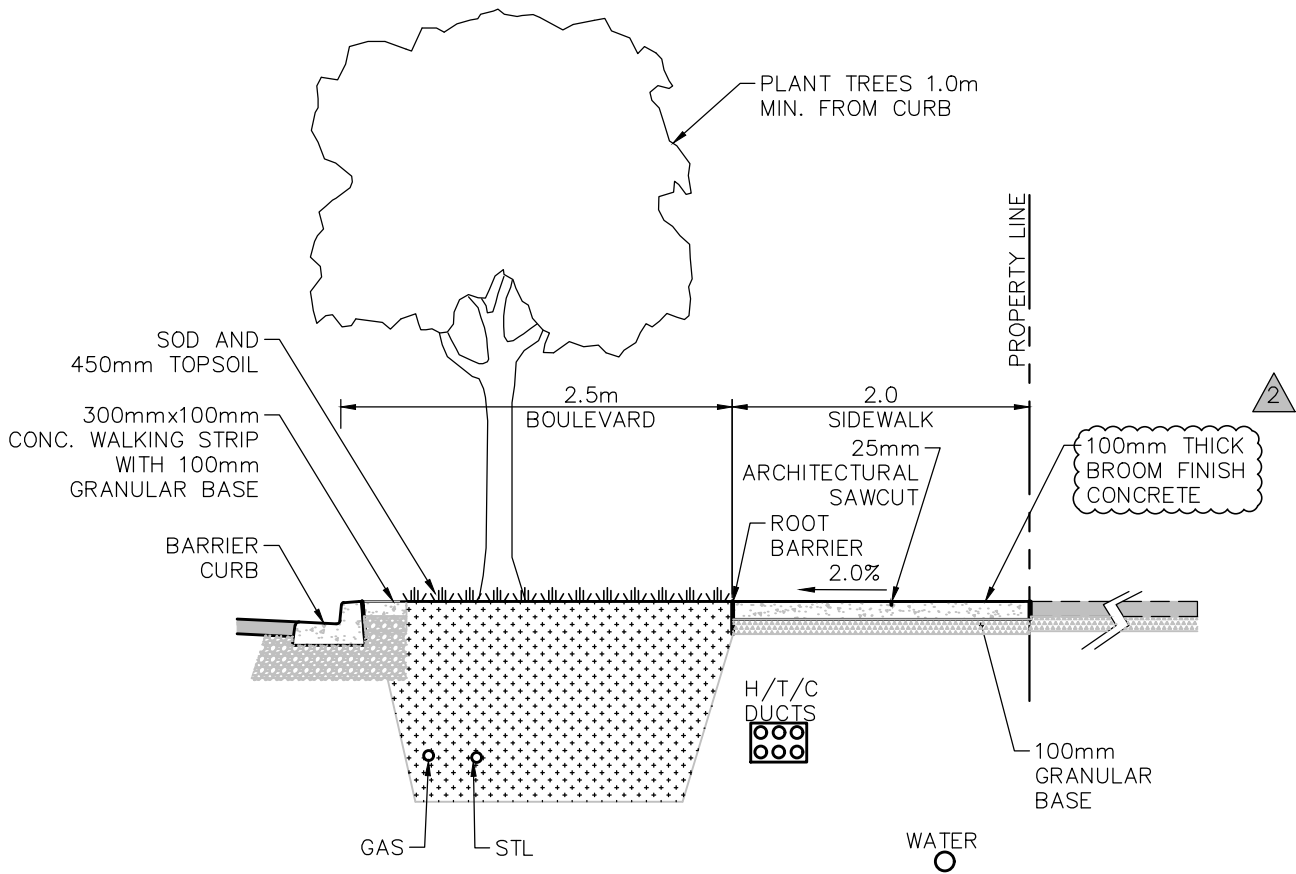

PLAN

3			All Dimensions Shown In Metres, Unless Otherwise Noted
2			
1	APRIL 2020	S. NEUMAN	Title LOCAL BOULEVARD FOR 20m ROW SOFTSCAPE FRONTAGE
	Revision Date	Approved	
 <p>CITY OF SURREY the future lives here.</p>			Approved By :  APRIL 2020 G.M. Engineering
CITY CENTRE STANDARD DRAWINGS			DRAWING NUMBER CCSD-8e



- NOTES:
- (1) PLANT MATERIAL TO BE SELECTED FROM LIST OF ACCEPTABLE PLANT MATERIAL CITY OF SURREY PARKS DIVISION STANDARD CONSTRUCTION DOCUMENTS.
 - (2) PROTECT PLANT MATERIAL FROM DAMAGE DURING TRANSPORTATION AND PLANTING.
 - (3) LOCATE AND FLAG ALL BURIED UTILITIES IN PLANTING BEDS PRIOR TO DIGGING TO ENSURE THAT UTILITIES ARE PROTECTED DURING CONSTRUCTION.
 - (4) DO NOT EXPOSE PLANTS TO DIRECT SUN OR FROST.
 - (5) PRUNE ONLY IN ACCORDANCE WITH STANDARD CONSTRUCTION DOCUMENTS.

3		All Dimensions Shown In Metres, Unless Otherwise Noted		
2	APRIL 2020 S. NEUMAN			
1	JULY 2017			
	Revision Date	Approved	Title LOCAL BOULEVARD FOR 20m ROW TYPICAL SOFTSCAPE SECTION (4.5m) BLVD	
		CITY CENTRE STANDARD DRAWINGS	Approved By :  APRIL 2020 G.M. Engineering	DRAWING NUMBER CCSD-8f

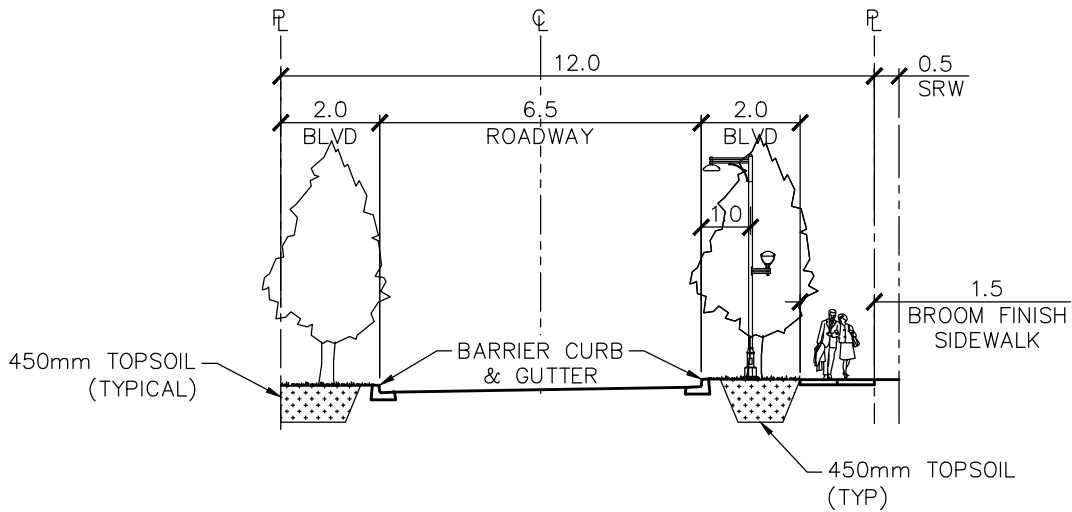
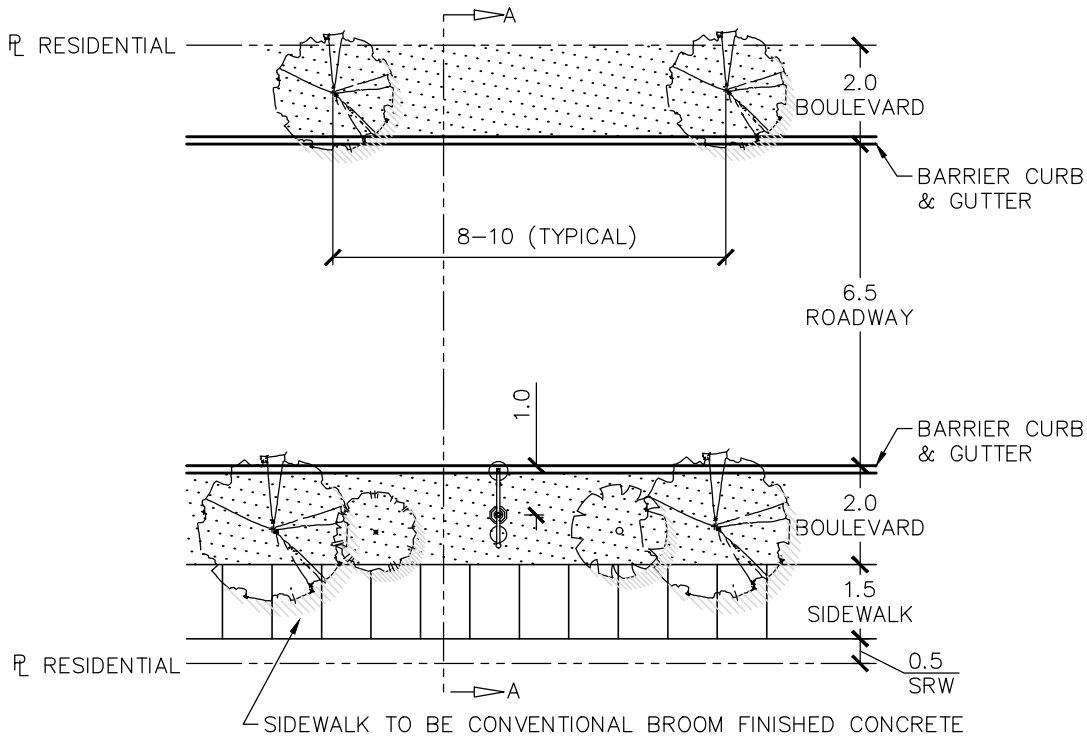



SECTION A-A

- NOTES: (1) TREE SPECIES TO BE AS PER CITY CENTRE STREET TREE AREA MAP CCSD-4.
 (2) BOULEVARD TO BE SODDED WITH MIN. 450mm THICK ABSORBANT TOPSOIL.
 (3) COLUMNER STREET TREES

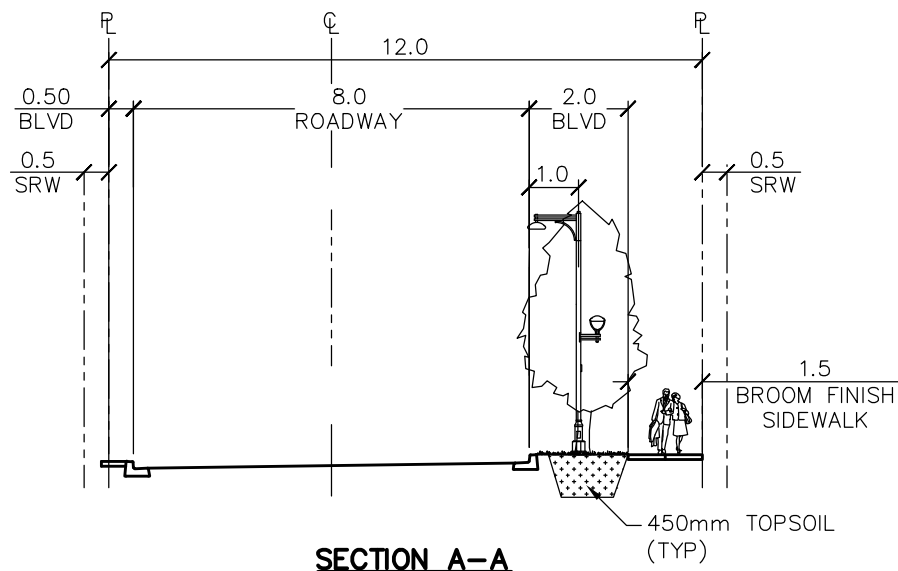
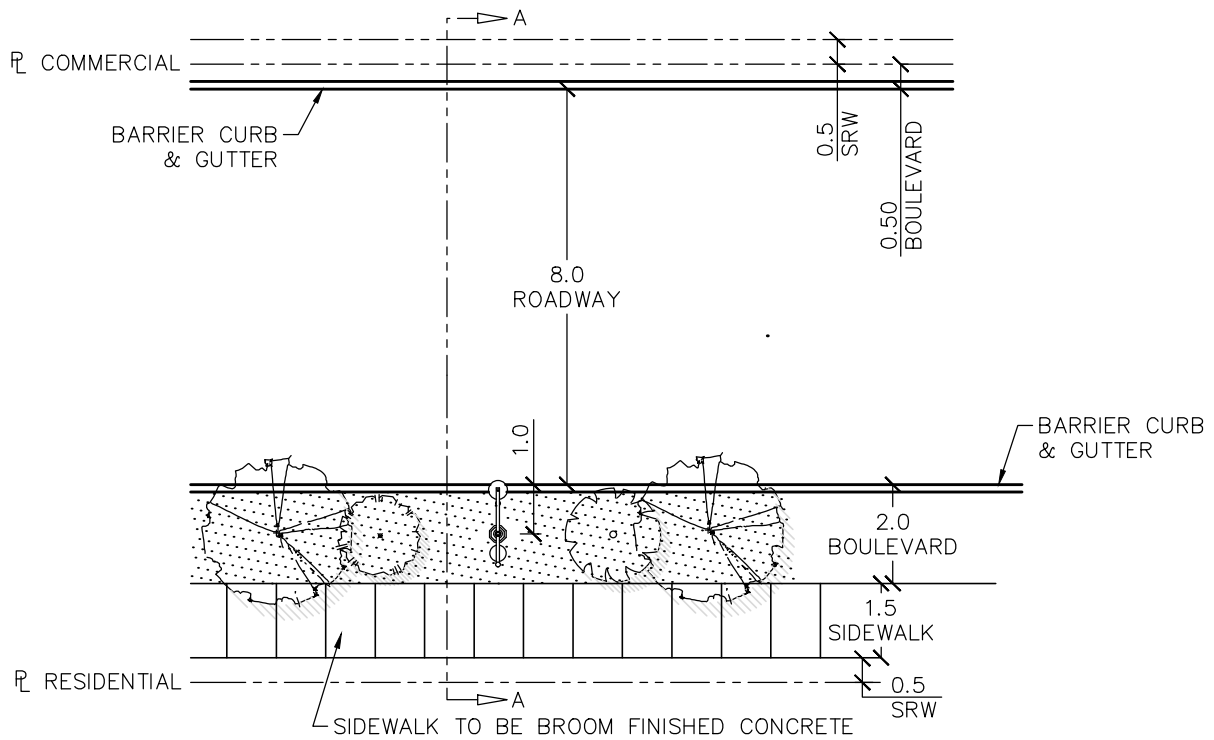
3			All Dimensions Shown In Metres, Unless Otherwise Noted
2			
1	APRIL 2020	S. NEUMAN	Title TYPICAL CROSS SECTION GREEN LANES (6.5m) PAVEMENT
	Revision Date	Approved	
			Approved By :
CITY CENTRE STANDARD DRAWINGS			DRAWING NUMBER CCSD-9a
APRIL 2020			G.M. Engineering



- NOTES:
- (1) TREE SPECIES TO BE AS PER CITY CENTRE STREET TREE AREA MAP CCSD-4.
 - (2) BOULEVARD TO BE SODDED WITH MIN. 450mm THICK ABSORBANT TOPSOIL.
 - (3) ADDITIONAL STREET TREES MAY BE PLACED IN SMALL GROUPINGS WITH A MIXTURE OF LARGE CANOPY AND MEDIUM UNDERSTORY TREES IN CURB EXTENSION AS DIRECTED BY ENGINEER.
 - (4) PARKING MAY BE PERMITTED IN LANE AS DIRECTED BY ENGINEER.

3			All Dimensions Shown In Metres, Unless Otherwise Noted
2			
1	APRIL 2020	S. NEUMAN	Title TYPICAL CROSS SECTION GREEN LANES (8.0m) PAVEMENT
	Revision Date	Approved	
 <p>CITY OF SURREY the future lives here.</p>			Approved By :  APRIL 2020 G.M. Engineering
CITY CENTRE STANDARD DRAWINGS			DRAWING NUMBER CCSD-9b

Apr 01 - 2020 - 2:59pm G:\GENERAL\Design Criteria Manual & Supplementary\MKCD\COM and SHMCD DRAFT 2020\SSD files\CCSSD\9b-TYPICAL CROSS SECTION GREEN LANES (8.0m) PAVEMENT.dwg/9b P206067

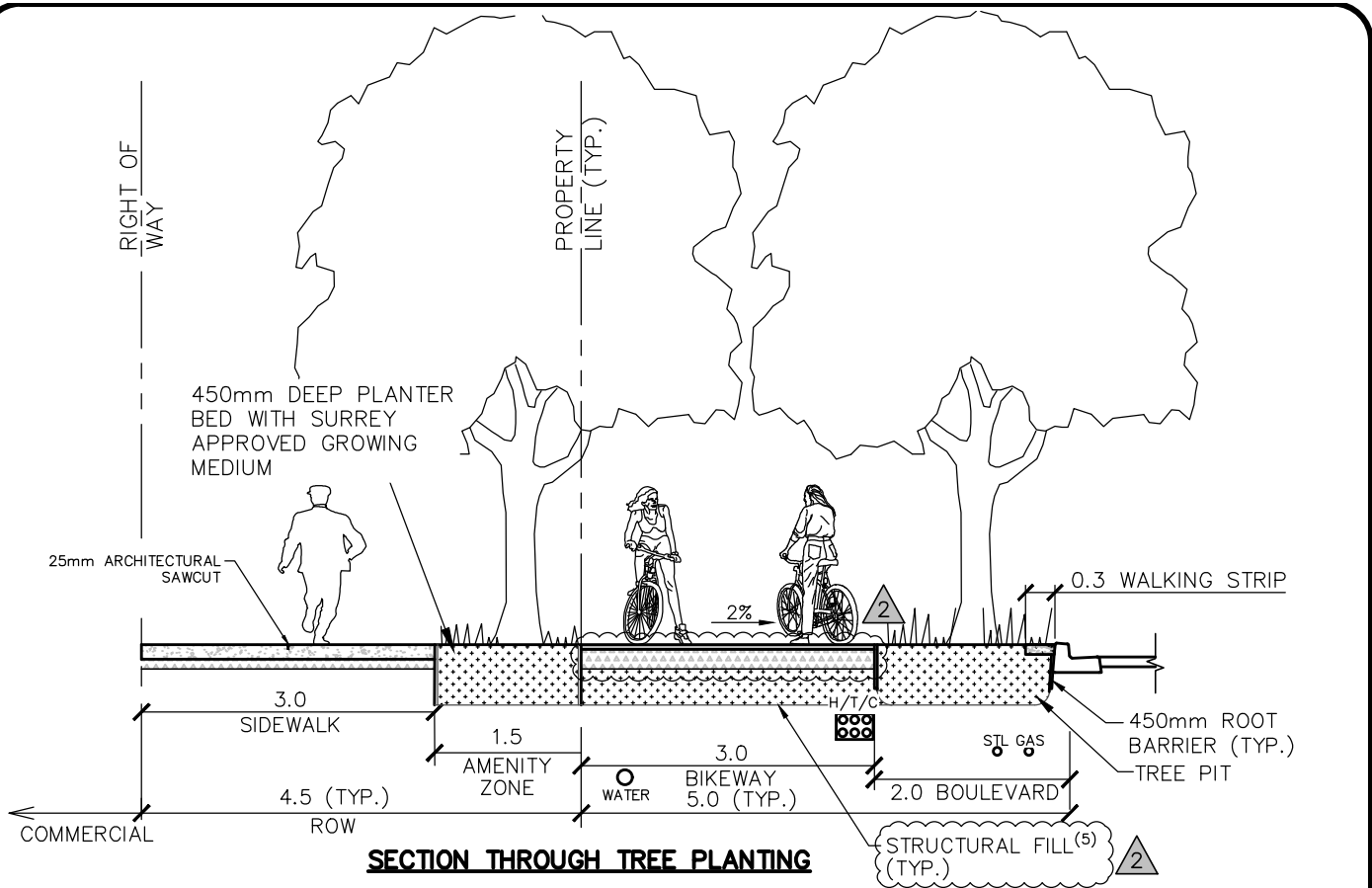

SECTION THROUGH TREE PLANTING

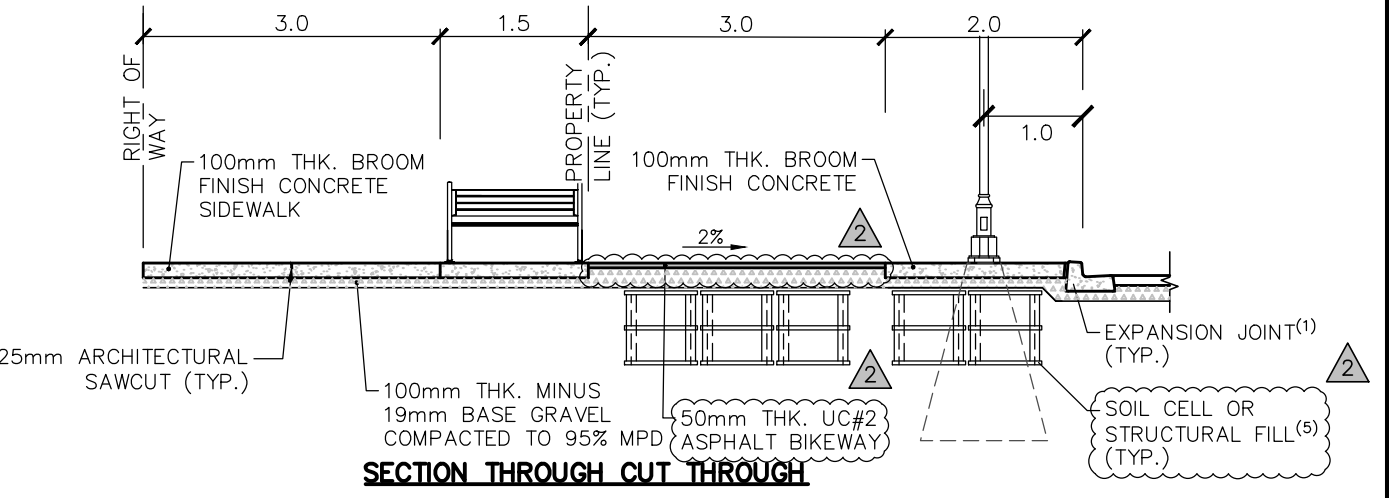

SECTION THROUGH CUT THROUGH

- NOTES:
- (1) EXPANSION JOINTS SHALL USE FULL DEPTH ASPHALT IMPREGNATED FIBREBOARD @ MAXIMUM 9m LONGITUDINAL SPACING. EXPANSION JOINTS SHALL BE PROVIDED AGAINST ALL VERTICAL EDGES AND CHANGE IN MATERIALS. 50mm SMOOTH TROWEL ON BOTH SIDES OF EXPANSION JOINT.
 - (2) CONTROL JOINTS SHALL HAVE A MAXIMUM 3m SPACING. CONTROL JOINTS SHALL BE SAWCUT ONLY.
 - (3) CONTROL JOINT AND EXPANSION JOINT LAYOUTS TO BE CHALK MARKED AND APPROVED BY LANDSCAPE ARCHITECT PRIOR TO COMPLETION.
 - (4) CONCRETE EDGE ALONG PROPERTY LINE TO HAVE 150mm TROWEL FINISH. ALL SCORELINES TO STOP PRIOR TO TROWELED EDGE.
 - (5) STRUCTURAL SOIL TO MEET SECTION 02727 OF SURREY PARK STANDARDS.

3	
2	APRIL 2020
1	JULY 2017
	Revision Date Approved

All Dimensions Shown In Metres,
Unless Otherwise Noted

Title **BC PARKWAY WITH HARDSCAPE BLVD –
CROSS SECTION**



Approved By : *[Signature]*
APRIL 2020 G.M. Engineering

DRAWING NUMBER
CCSD-10b

Apr 01 - 2020 - 3:08pm C:\GENERAL\Design Criteria Manual & Supplementary\MKCD\DRIFT 2020\USD files\CCSD\10b BC Parkway with Hardscape Blvd - Cross Section.dwg/10b_P206067

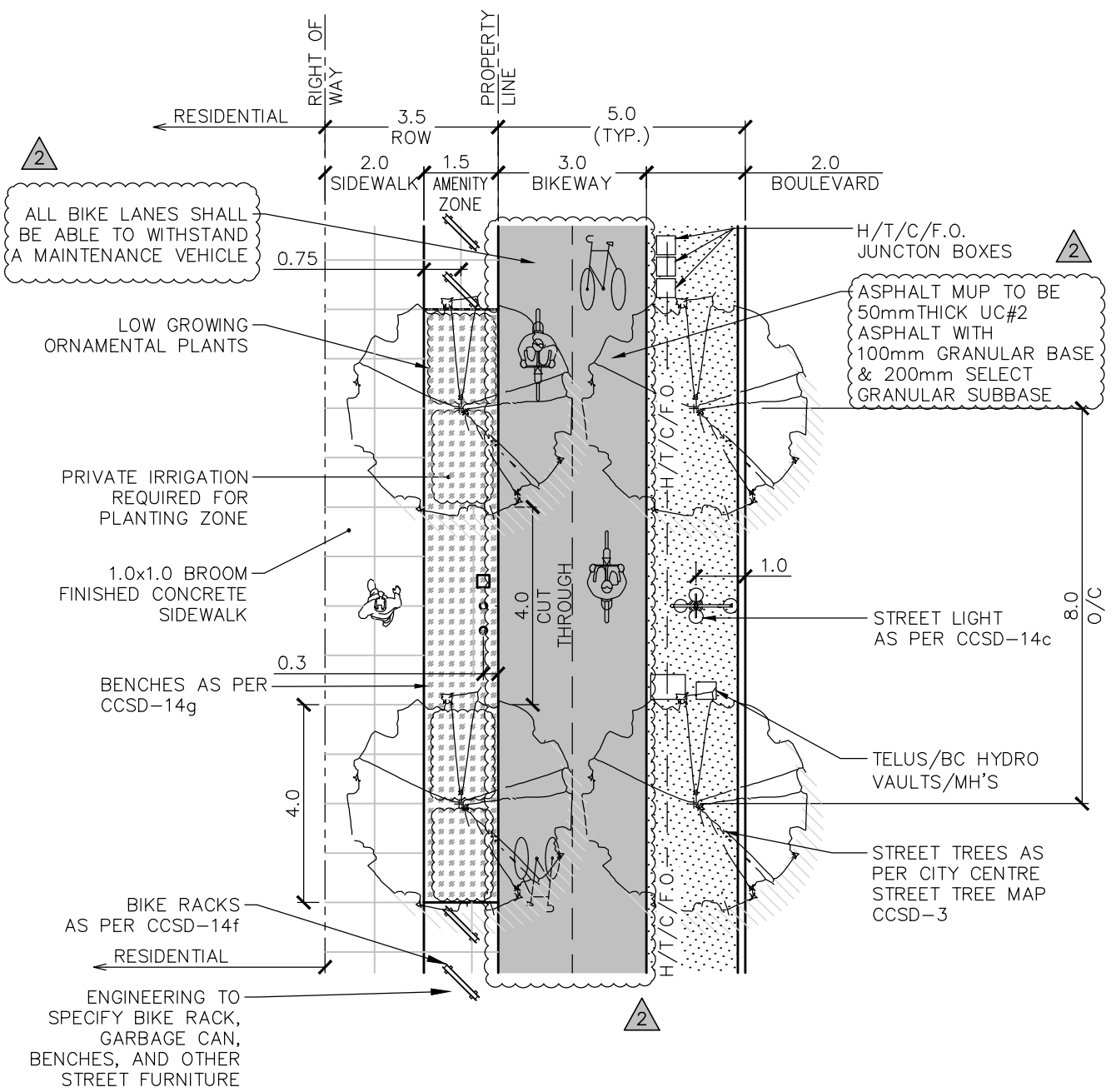

3	
2	APRIL 2020
1	JULY 2017
	Revision Date
	Approved

All Dimensions Shown In Metres, Unless Otherwise Noted

Title **BC PARKWAY WITH SOFTSCAPE BOULEVARD**



Approved By : *[Signature]*

APRIL 2020 G.M. Engineering

DRAWING NUMBER
CCSD-10c

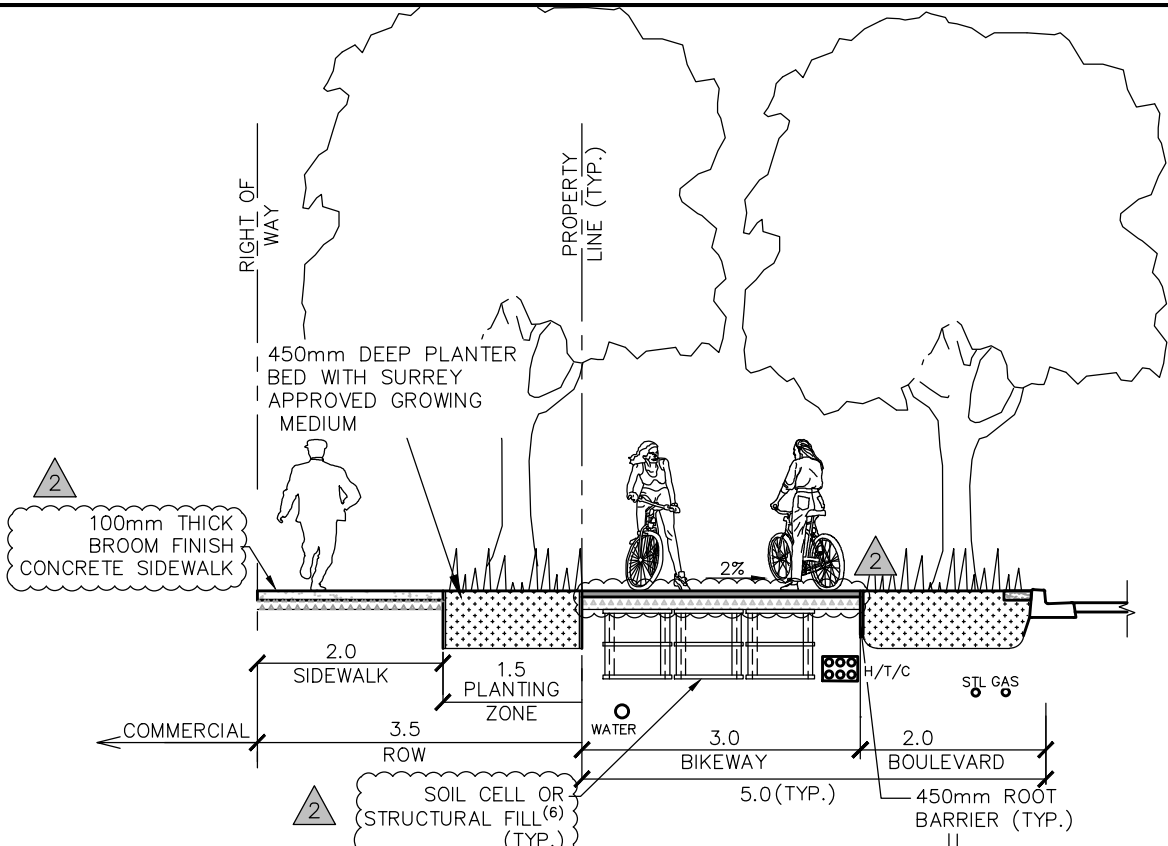

SECTION THROUGH TREE PLANTING

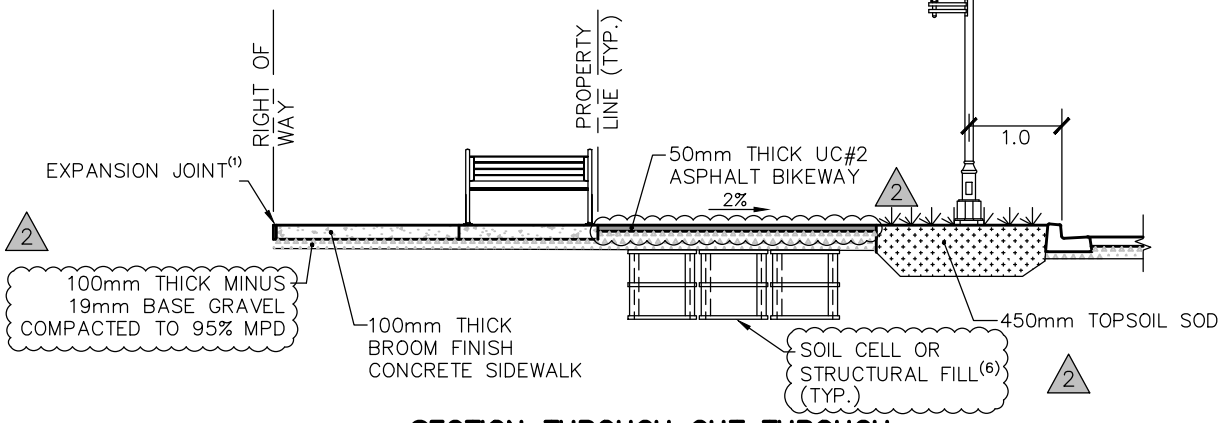

SECTION THROUGH CUT THROUGH

- NOTES:
- (1) EXPANSION JOINTS SHALL USE FULL DEPTH ASPHALT IMPREGNATED FIBREBOARD @ MAXIMUM 9m LONGITUDINAL SPACING. EXPANSION JOINTS SHALL BE PROVIDED AGAINST ALL VERTICAL EDGES AND CHANGE IN MATERIALS. 50mm SMOOTH TROWEL ON BOTH SIDES OF EXPANSION JOINT.
 - (2) CONTROL JOINTS SHALL HAVE A MAXIMUM 3m SPACING. CONTROL JOINTS SHALL BE SAWCUT ONLY.
 - (3) CONTROL JOINT AND EXPANSION JOINT LAYOUTS TO BE CHALK MARKED AND APPROVED BY LANDSCAPE ARCHITECT PRIOR TO COMPLETION.
 - (4) CONCRETE FINISH TO MATCH EXISTING CONCRETE SIDEWALK FINISH
 - (5) CONCRETE EDGE ALONG PROPERTY LINE TO HAVE 150mm TROWEL FINISH. ALL SCORELINES TO STOP PRIOR TO TROWELED EDGE.
 - (6) STRUCTURAL SOIL TO MEET SECTION 02727 OF SURREY PARK STANDARDS.

3		All Dimensions Shown In Metres, Unless Otherwise Noted	
2	APRIL 2020		
1	JULY 2017		
	Revision Date	Approved	Title BC PARKWAY WITH SOFTSCAPE BLVD – CROSS SECTION
		CITY CENTRE STANDARD DRAWINGS Approved By : APRIL 2020 G.M. Engineering	DRAWING NUMBER CCSD-10d

Apr 01 - 2020 - 3:15pm - G:\GENERAL\Design Criteria Manual & Supplementary Files\CCSD files\CCSD\10d BC Parkway with Softscape - Cross Section.dwg/10d - P200007

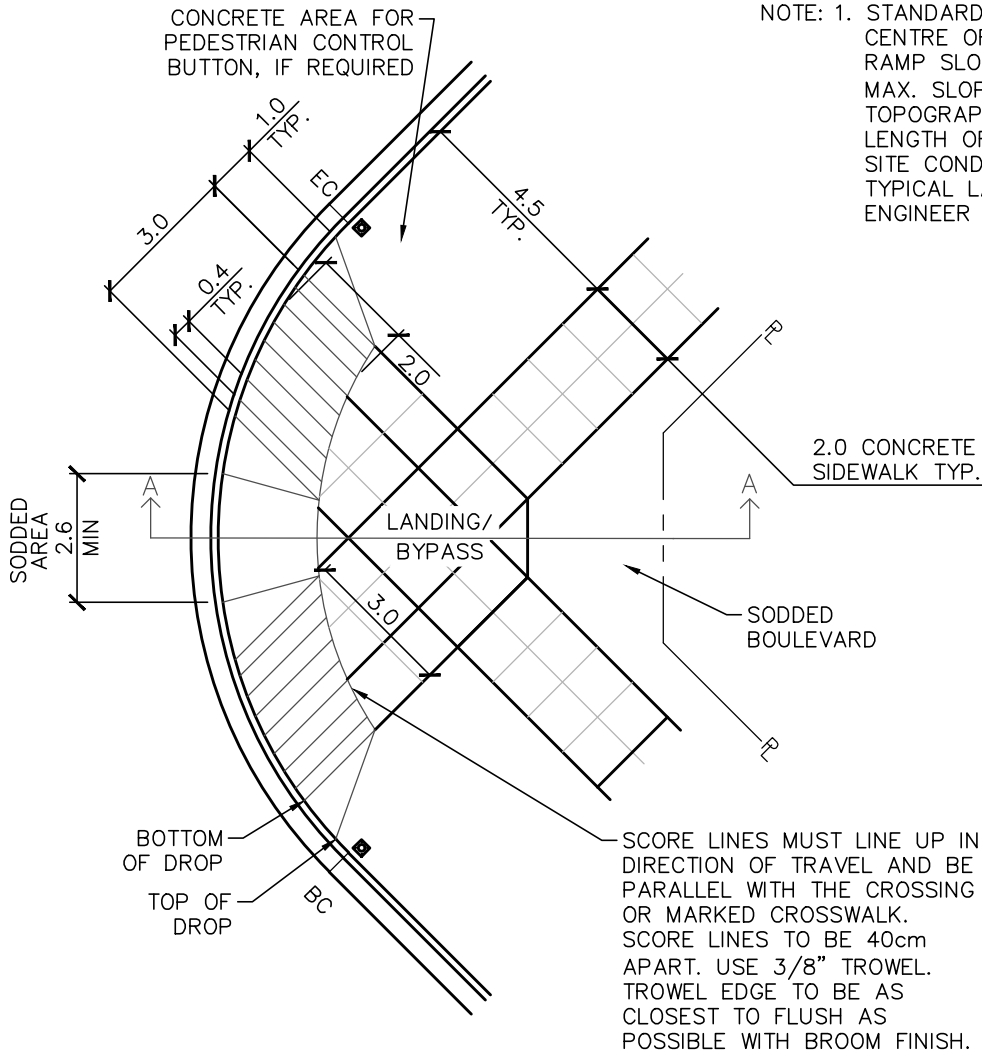

SPLIT LETDOWN

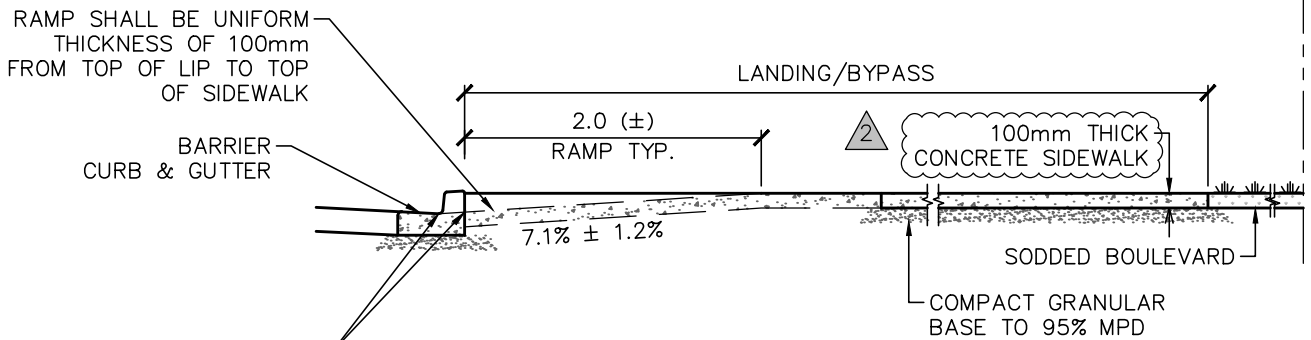

SECTION A-A CURB RAMP

3		
2	APRIL 2020	S. NEUMAN
1	JULY	
	Revision Date	Approved

All Dimensions Shown In Metres, Unless Otherwise Noted	
Title	SPLIT LETDOWN AT INTERSECTION BOULEVARD GREATER THAN 4.50m

CITY CENTRE STANDARD DRAWINGS

Approved By :

APRIL 2020 G.M. Engineering

DRAWING NUMBER
CCSD-11b

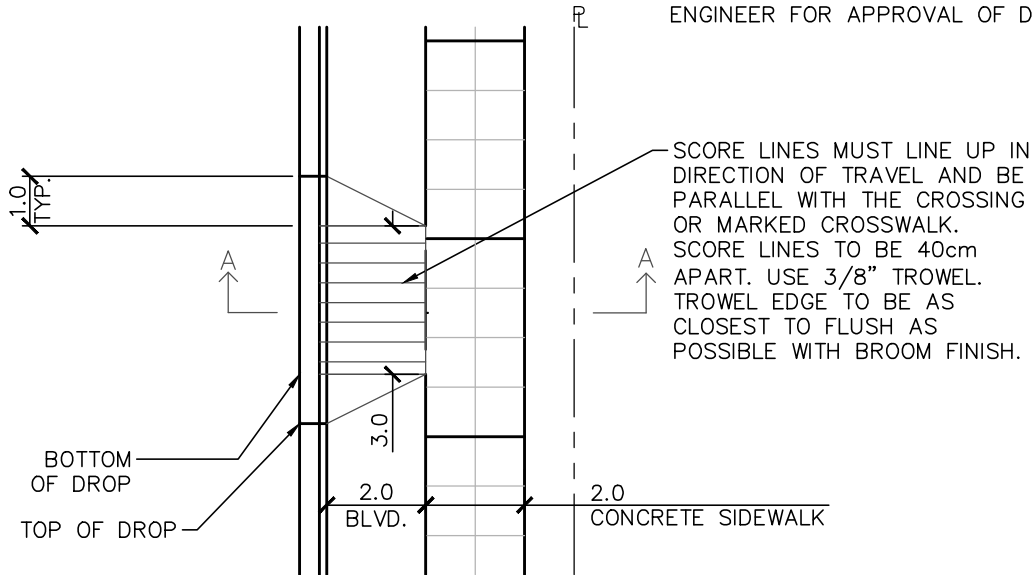

NOTE: 1. STANDARD RAMP LENGTH: 2.0m AT CENTRE OF RAMP. RECOMMENDED RAMP SLOPE: 7.1% ± 1.2%. MAX. SLOPE 8.3% (1:12) WHERE TOPOGRAPHY PERMITS. ADJUST LENGTH OF RAMP AS REQUIRED WHEN SITE CONDITIONS DO NOT PERMIT TYPICAL LAYOUT. CONTACT CITY ENGINEER FOR APPROVAL OF DESIGN.

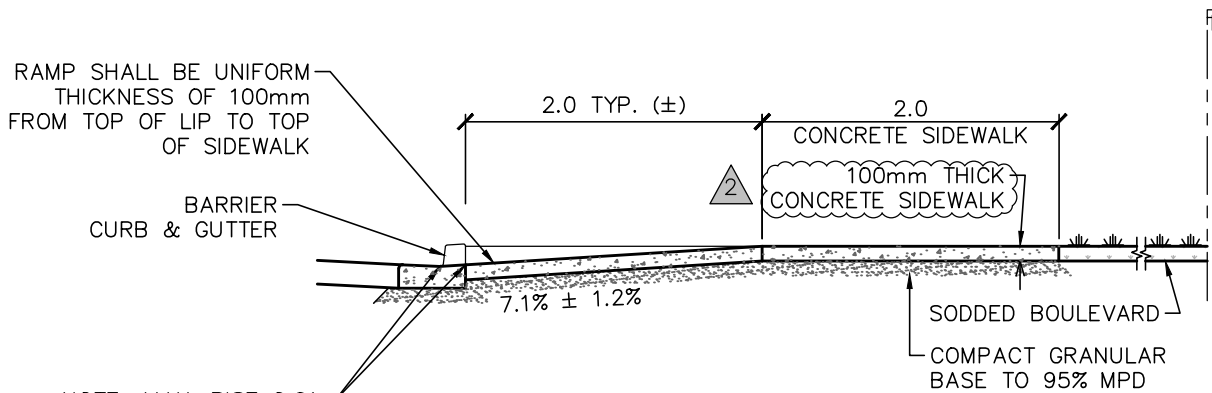

PLAN



SECTION A-A CURB RAMP

3		All Dimensions Shown In Metres, Unless Otherwise Noted		
2	APRIL 2020 S. NEUMAN			
1	JULY 2017			
	Revision Date	Approved	Title	SINGLE RAMP LETDOWN WITH PARALLEL SCORING
		CITY CENTRE STANDARD DRAWINGS	Approved By :	 G.M. Engineering
			APRIL 2020	DRAWING NUMBER CCSD-11c

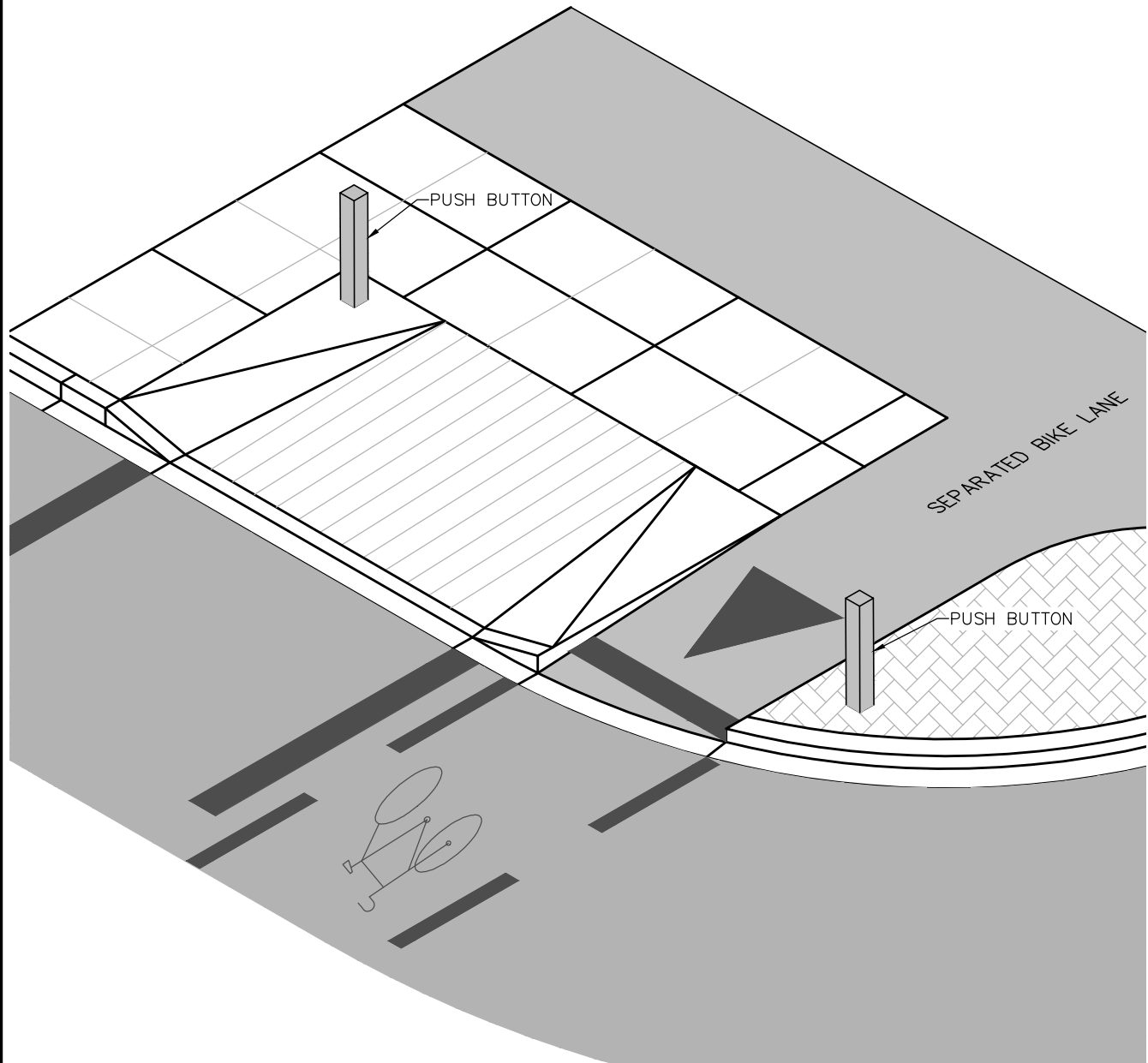

3		
2		
1	APRIL 2020	S. NEUMAN
	Revision Date	Approved

All Dimensions Shown In Metres,
Unless Otherwise Noted

Title **TYPICAL TREATMENT TWO LETDOWNS FOR
PROTECTED INTERSECTION**

CITY OF SURREY
the future lives here.

CITY CENTRE
STANDARD
DRAWINGS

Approved By :

APRIL 2020 G.M. Engineering

DRAWING NUMBER
CCSD-11d

Apr 01 - 2020 - 3:15pm G:\GENERAL\Design Criteria Manual & Supplementary Manual\DCM and SLM\CD DRAFT 2020\SSD files\CCSD\11d TYPICAL TREATMENT TWO LETDOWNS FOR PROTECTED INTERSECTION.dwg/11d P200007

TYPE 1

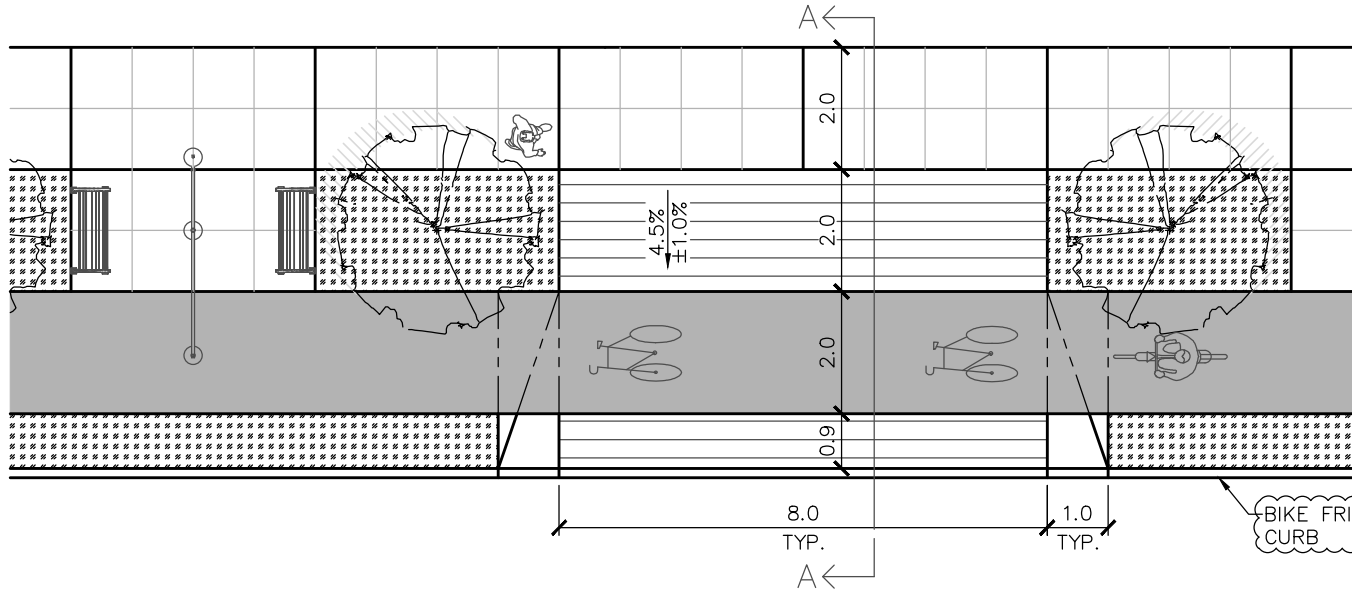

2 RAMP SHALL BE UNIFORM THICKNESS FROM TOP OF LIP TO FRONT OF SIDEWALK
 -200mm MULTI FAMILY/COMMERCIAL/INDUSTRIAL
 -150mm SINGLE FAMILY DRIVEWAY

25 LIP WITH 15 RADIUS

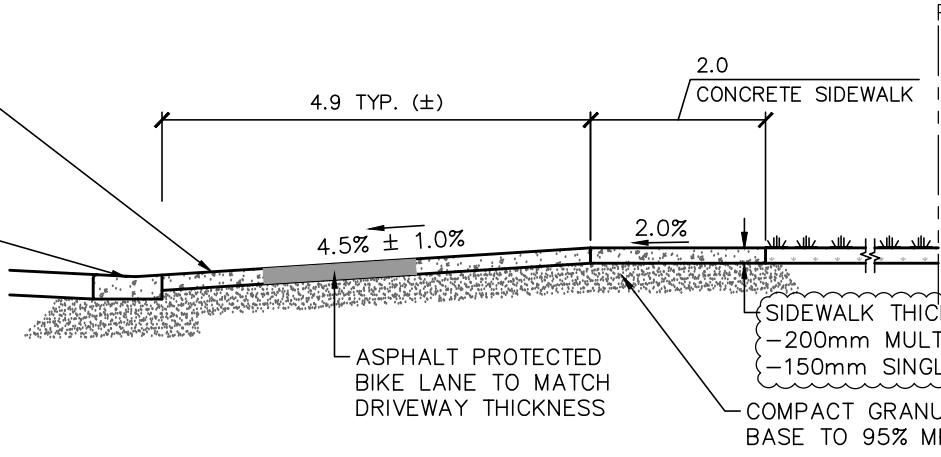

2 SIDEWALK THICKNESS:
 -200mm MULTI FAMILY/COMMERCIAL/INDUSTRIAL
 -150mm SINGLE FAMILY DRIVEWAY

3		
2	APRIL 2020	S. NEUMAN
1	JULY 2017	
	Revision Date	Approved

All Dimensions Shown In Metres,
 Unless Otherwise Noted

Title **DRIVEWAY TYPE 1 PLAN & SECTION VIEW (30m) ROW**

Approved By : 
 APRIL 2020 G.M. Engineering

DRAWING NUMBER
CCSD-12a



CITY CENTRE
 STANDARD
 DRAWINGS

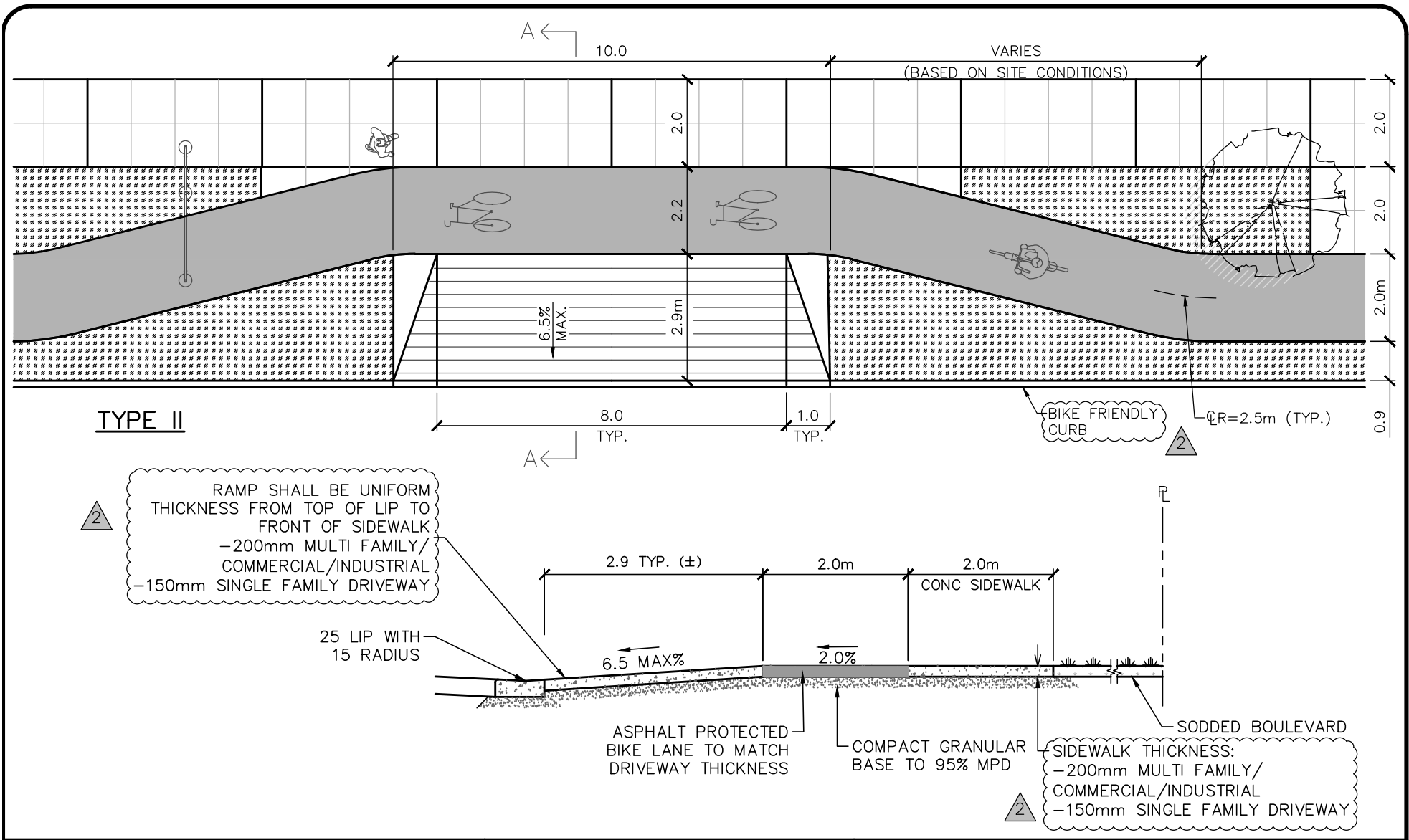

3		
2	APRIL 2020	S. NEUMAN
1	JULY 2017	
	Revision Date	Approved



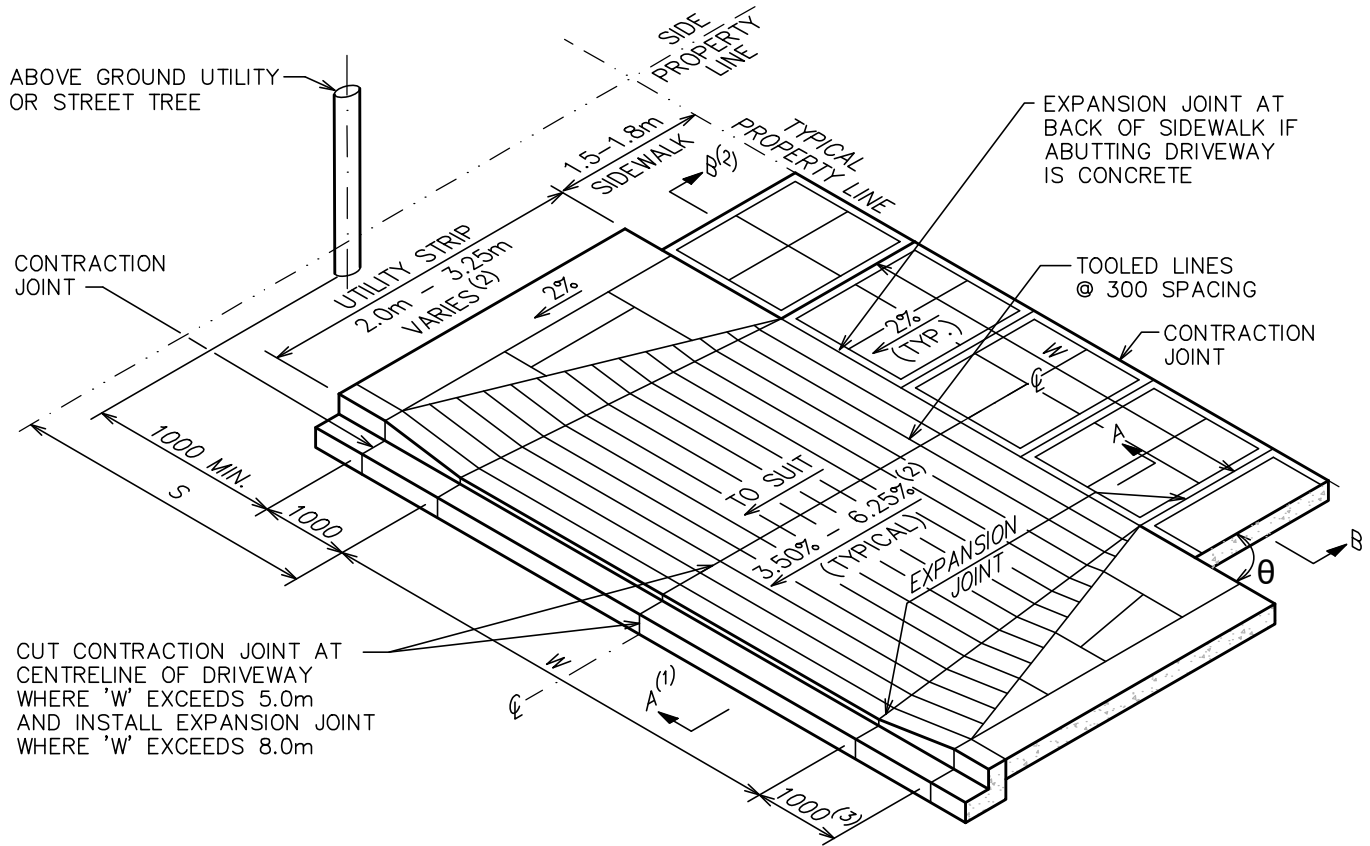

All Dimensions Shown In Metres, Unless Otherwise Noted	
Title	DRIVEWAY TYPE II PLAN & SECTION VIEW (30m) ROW
Approved By :	
APRIL 2020	G.M. Engineering
DRAWING NUMBER	CCSD-12b



ZONE	OPERATION	W		S MIN. DISTANCE FROM SIDE PROPERTY LINE (m)	θ-MIN. ANGLE BTWN. THE FRONTAGE PROP. LINE AND THE EDGE OF DRIVEWAY (DEG.)
		MIN. (m)	STD. (m)		
SINGLE FAMILY RESIDENTIAL	N/A	4.5	6.0	1.2	90
MULTI FAMILY RESIDENTIAL	TWO WAY	N/A	7.3	2.0	90
	ONE WAY	N/A	4.5	2.0	45
LANE	RESIDENTIAL	N/A	7.3	2.0	90
	COMMERCIAL	N/A	9.3	2.0	45
COMMERCIAL	TWO WAY	7.3	9.0	2.0	90
	ONE WAY	N/A	4.5	2.0	45
INDUSTRIAL	TWO WAY	9.0	11.0	2.0	90
	ONE WAY	N/A	5.0	2.0	30

- NOTES: (1) FOR SECTION A-A REFER TO SSD-R.42.1.
 (2) FOR UTILITY STRIP LESS THAN 2.0m, LETDOWN SLOPE SHALL BE 2% AND REFER TO SECTION B-B ON SSD-R.42.1.
 (3) FLARE IS NOT PERMITTED FOR SINGLE FAMILY RESIDENTIAL UNLESS DIRECTED BY ENGINEER.
 (4) EXPANSION JOINTS SHALL USE FULL DEPTH ASPHALT IMPREGNATED FIBREBOARD @ MAXIMUM 9m LONGITUDINAL SPACING. EXPANSION JOINTS SHALL BE PROVIDED AGAINST ALL VERTICAL EDGES AND CHANGE IN MATERIALS.

3			All Dimensions Shown In Metres, Unless Otherwise Noted
2			
1	APRIL 2020	S. NEUMAN	Title LOCAL ROAD DRIVEWAYS
	Revision Date	Approved	
 CITY CENTRE STANDARD DRAWINGS			Approved By :  APRIL 2020 G.M. Engineering
			DRAWING NUMBER CCSD-12c

Apr 02 2020 - 8:06am C:\GENERAL\Design Criteria Manual & Supplementary\MKCD\CDM and SIMCD\ DRAFT 2020\SSD files\CCSSD\12c LOCAL ROAD DRIVEWAYS.dwg/12c P206067

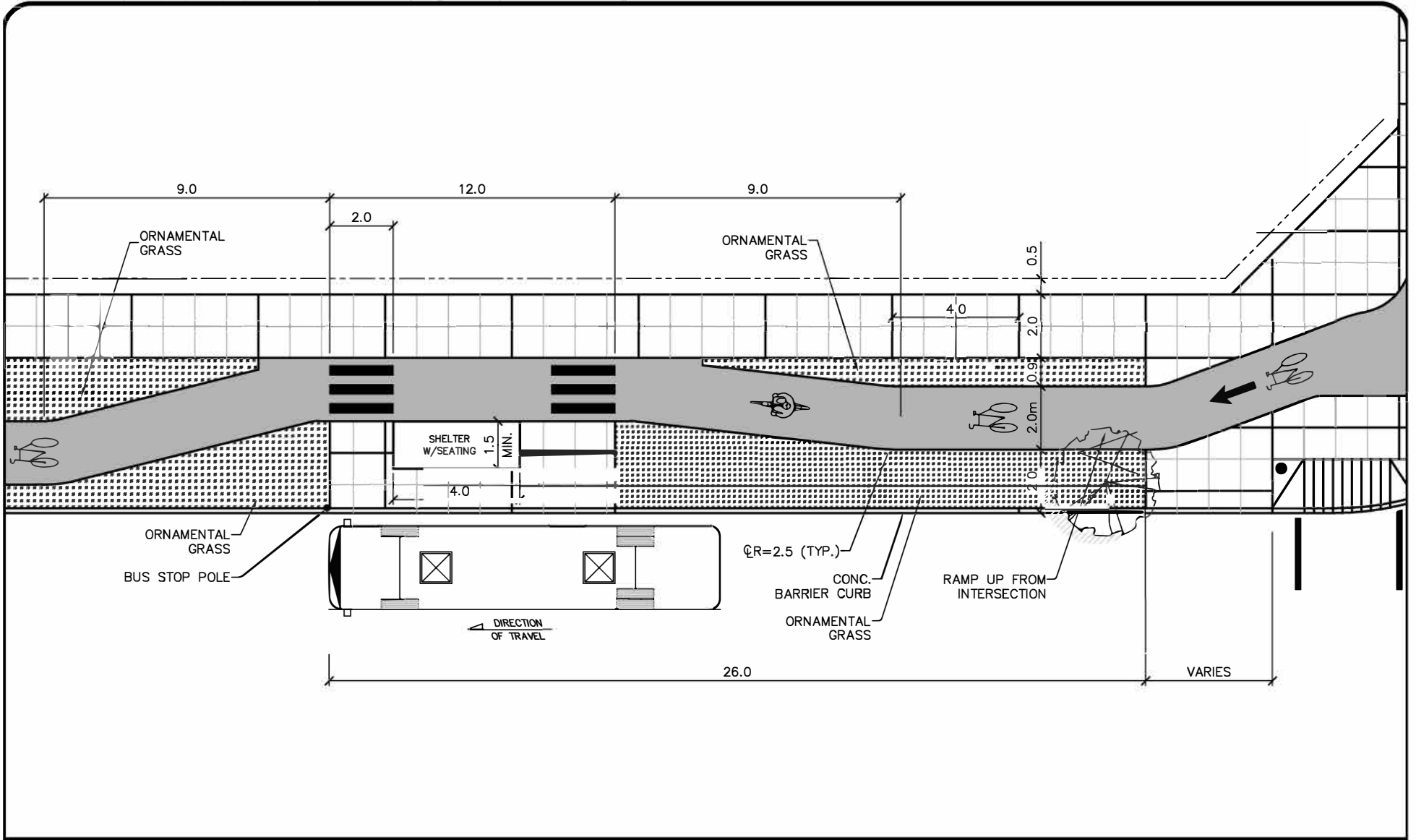

3		
2	APRIL 2020	S. NEUMAN
1	JULY 2017	<i>S. Neuman</i>
	Revision Date	Approved

CITY OF SURREY
CITY CENTRE STANDARD DRAWINGS

All Dimensions Shown In Metres, Unless Otherwise Noted

Title **TYPICAL BUS STOP PLAN VIEW (30m) ROW**

Approved By : *G.M. Engineering*

APRIL 2020 G.M. Engineering

DRAWING NUMBER **CCSD-13a**



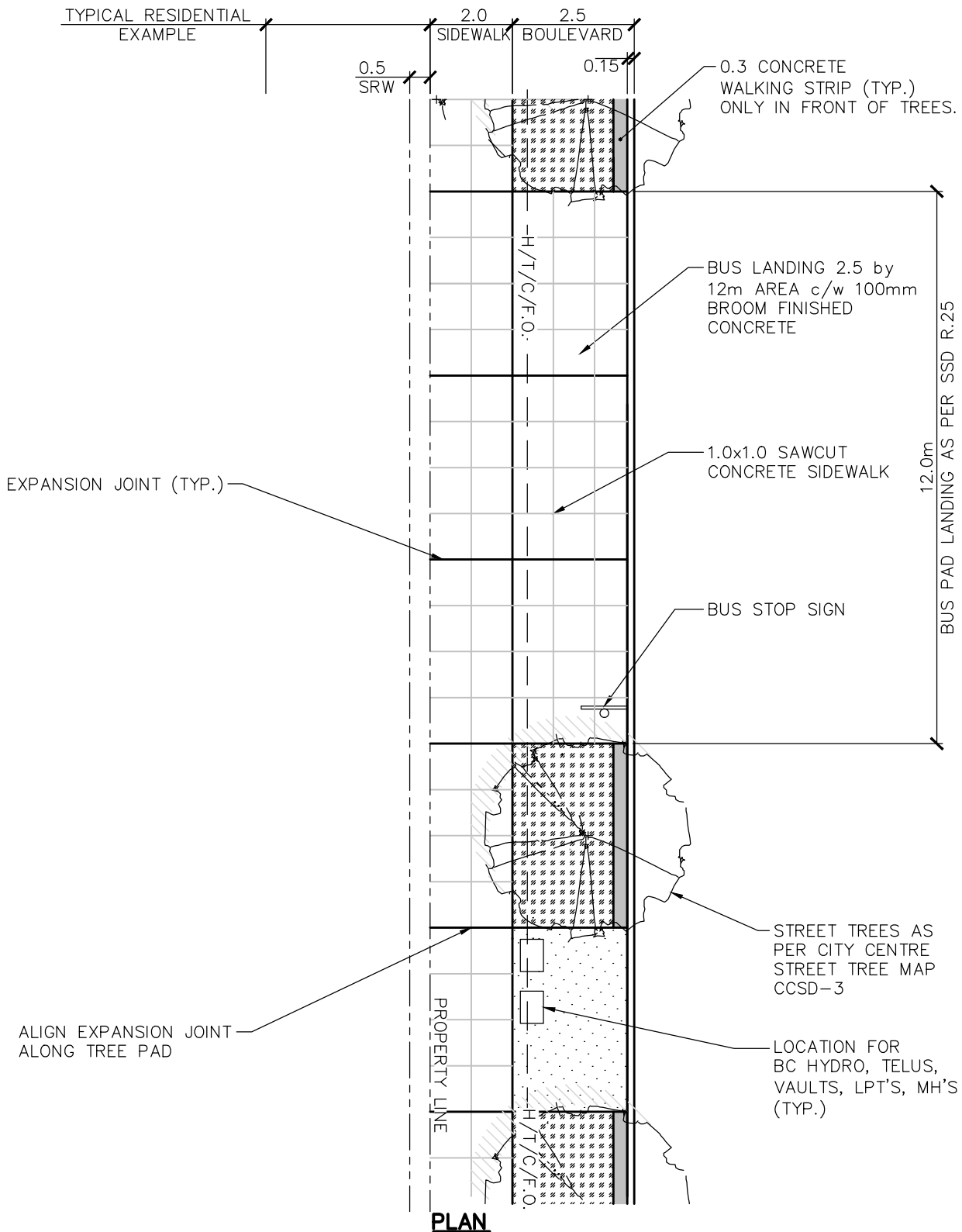

3		
2		
1	APRIL 2020	S. NEUMAN
	Revision Date	Approved

All Dimensions Shown In Metres, Unless Otherwise Noted	
Title	LOCAL BOULEVARD FOR 20m ROW BUS STOP FOR (4.5m) FRONTAGE

CITY OF SURREY
 the future lives here.

CITY CENTRE STANDARD DRAWINGS

Approved By :



 G.M. Engineering

APRIL 2020

DRAWING NUMBER

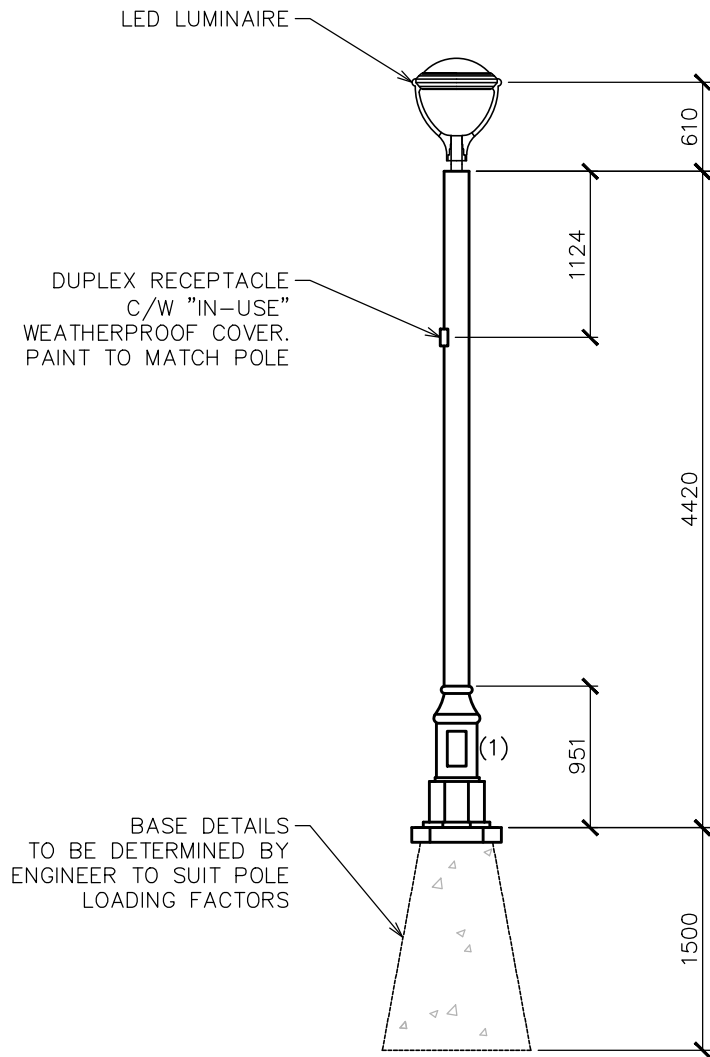

CCSD-13b

Apr 02 2020 7:50am C:\CENTRAL\Design Centre\Manual & Supplementary Files\2020\SSD Files\CCSD\Job LOCAL BOULEVARD FOR 20m ROW BUS STOP FOR (4.5m) FRONTAGE.dwg/3b - P200007



TYPICAL PROPOSED TYPE 'A'
DECORATIVE LUMINAIRE POST

- NOTES: (1) BOX FOR FUSE AND PHOTOCCELL TO BE INSTALLED WHERE IDENTIFIED BY STREETLIGHT ENGINEER.
 (2) POLE TO BE POWDER COATED RAL 7016 (GREY).

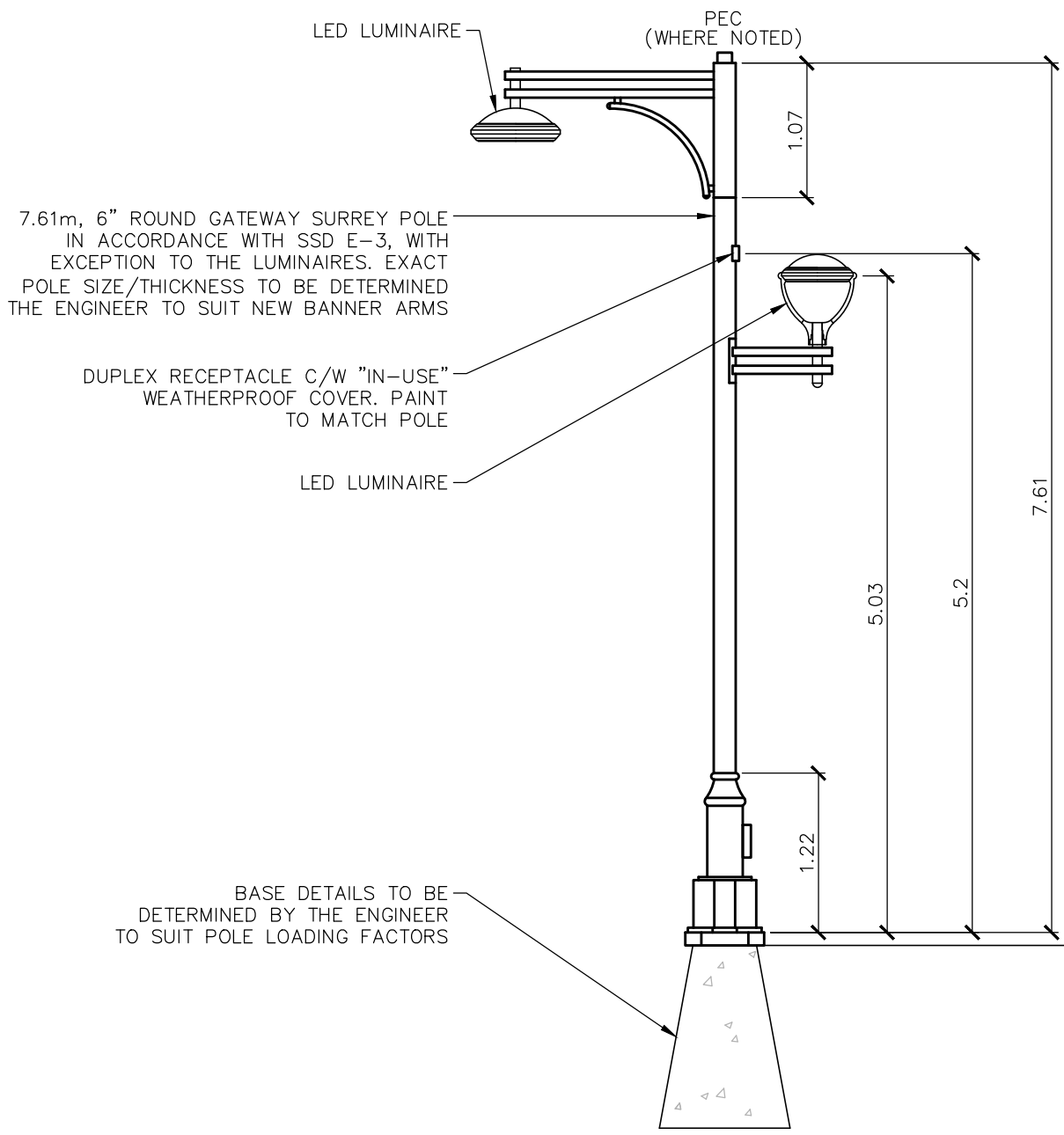

3			All Dimensions Shown In Metres, Unless Otherwise Noted
2			
1	APRIL 2020	S. NEUMAN	Title STREET LIGHTS – TYPE 'A'
	Revision Date	Approved	
 <p>CITY OF SURREY the future lives here.</p>			Approved By :  APRIL 2020 G.M. Engineering
CITY CENTRE STANDARD DRAWINGS			DRAWING NUMBER CCSD-14a

Apr 02 2020 - 7:50am - G:\CENTRAL Design Centre Manual & Supplementary\IMCD\001 and SIMCD DRAFT 2020\SSD files\CCSD\14a Street Lights - Type 'A'.dwg/14a - P200007



**TYPICAL PROPOSED TYPE 'B'
DECORATIVE LUMINAIRE POLE**

- NOTES: (1) TYPICAL 32m SPACING ON OPPOSITE SIDES, NOT STAGGERED
SUBJECT TO ENGINEER APPROVAL
(2) SUBJECT TO EXCEEDING ILLUMINATION REQUIREMENTS.
(3) POLE TO BE POWDER COATED RAL 7016 (GREY).

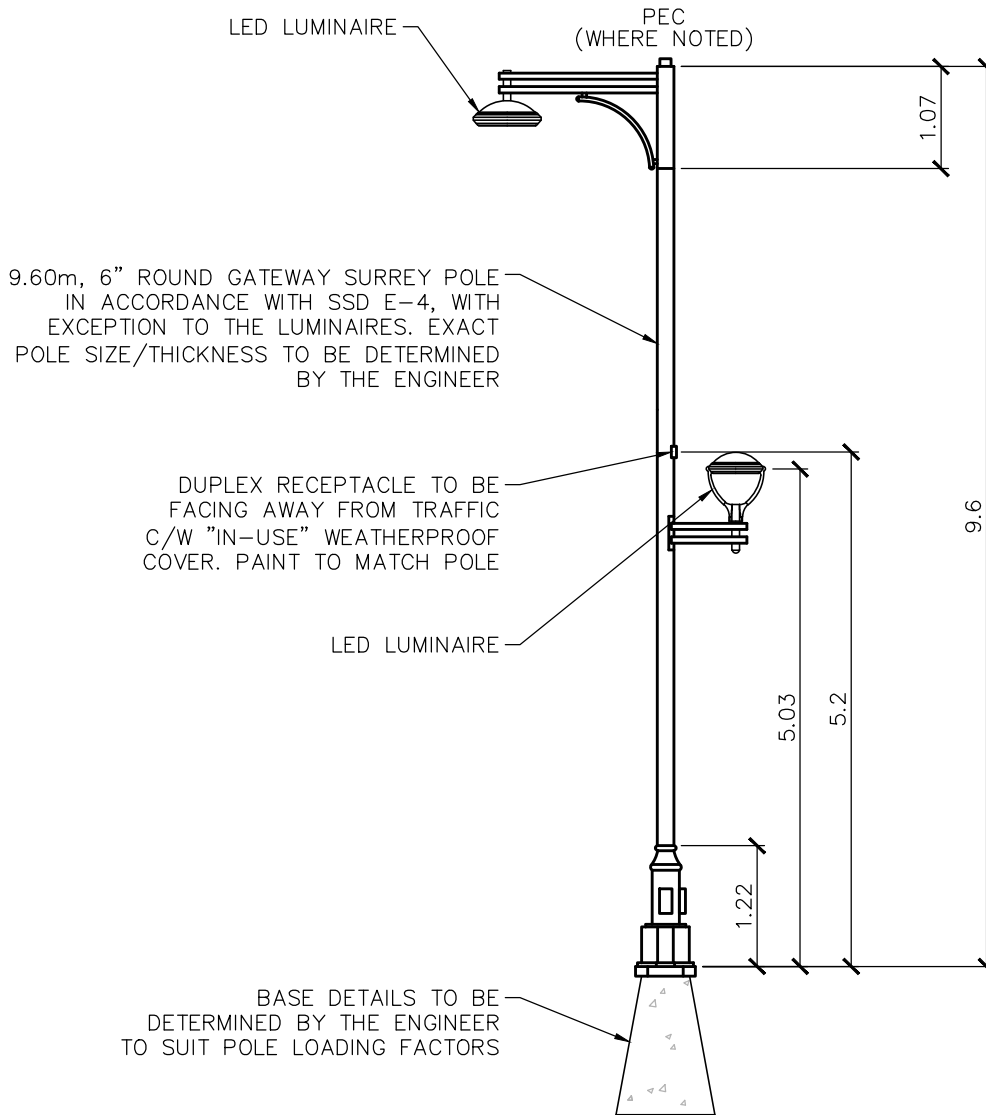

3			All Dimensions Shown In Metres, Unless Otherwise Noted
2			
1	APRIL 2020	S. NEUMAN	
	Revision Date	Approved	Title STREET LIGHTS – TYPE 'B' WITH PEDESTRIAN LIGHT
 <p>CITY OF SURREY the future lives here.</p>			Approved By :  APRIL 2020 G.M. Engineering
CITY CENTRE STANDARD DRAWINGS			DRAWING NUMBER CCSD-14b

Apr 02 2020 - 7:49am C:\GENERAL\Design Criteria Manual & Supplementary\MISC\DCM and SLMCD DRAFT 2020\SSD files\CCSD\14b Street Lights - Type 'B' with Pedestrian Light.dwg / 14b - P200007



**TYPICAL PROPOSED TYPE 'C'
DECORATIVE LUMINAIRE POLE**

- NOTES:
- (1) TYPICAL 40m SPACING ON OPPOSITE SIDES, NOT STAGGERED SUBJECT TO ENGINEER APPROVAL
 - (2) SUBJECT TO EXCEEDING ILLUMINATION REQUIREMENTS
 - (3) 11m POLE MAY BE REQUIRED.
 - (4) POLE TO BE POWDER COATED RAL 7016 (GREY).
 - (5) TO ACCOMMODATE BANNER ARMS, CONFIRM WIND LOADING WITH STRUCTURAL ENGINEERING

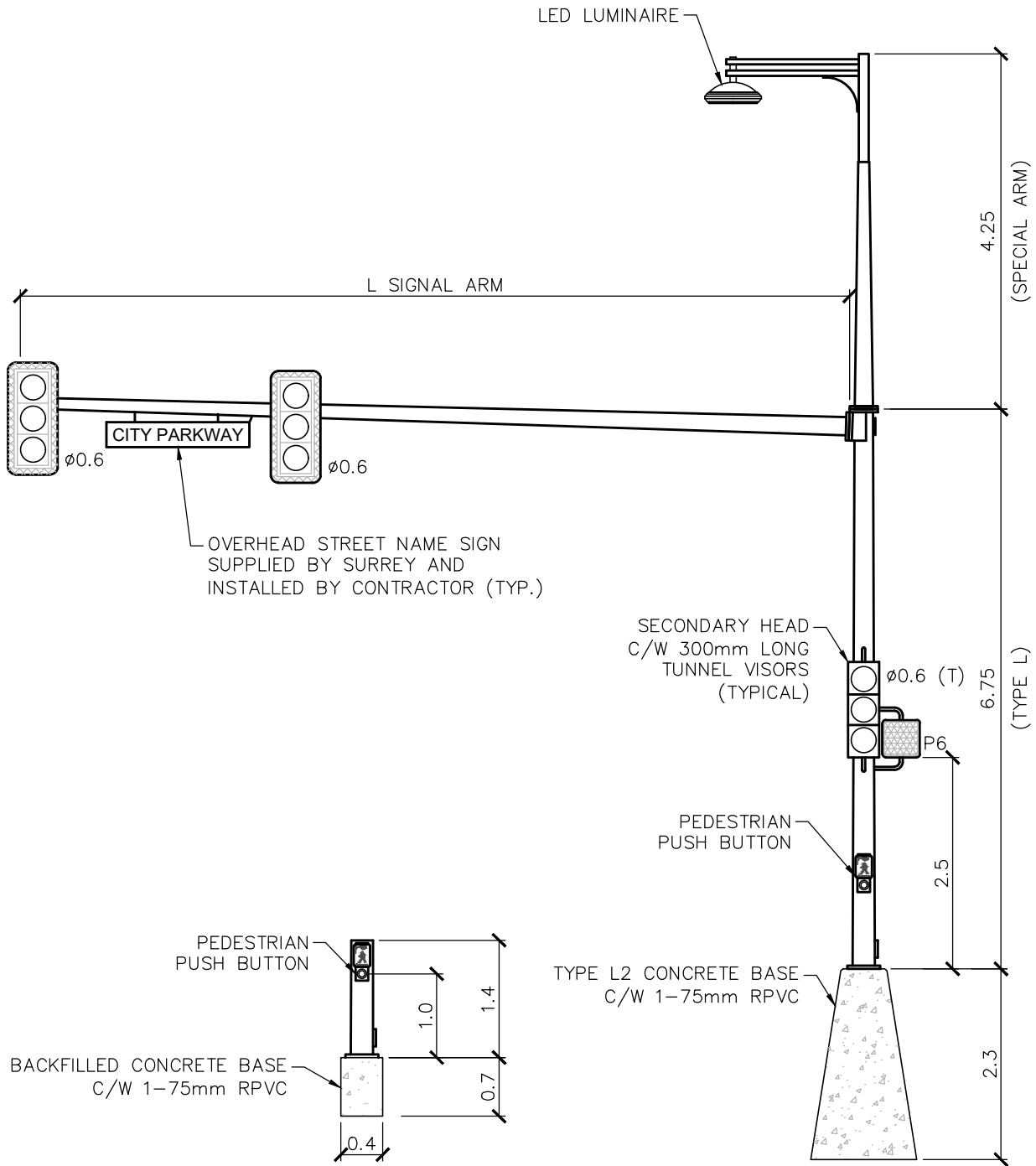

3			All Dimensions Shown In Metres, Unless Otherwise Noted	
2				
1	APRIL 2020	S. NEUMAN	Title STREET LIGHTS – TYPE C PEDESTRIAN LIGHT	
	Revision Date	Approved		
 <p>CITY OF SURREY the future lives here.</p>			Approved By :  APRIL 2020 G.M. Engineering	DRAWING NUMBER CCSD-14c



TYPICAL PROPOSED PEDESTRIAN PUSH BUTTON

TYPICAL PROPOSED TYPE 'L' TRAFFIC SIGNAL POLE

NOTES: (1) POLES TO BE POWDER COATED RAL 7016 (GREY).

3			All Dimensions Shown In Metres, Unless Otherwise Noted
2			
1	APRIL 2020	S. NEUMAN	
	Revision Date	Approved	Title TRAFFIC SIGNAL POLE
 <p>CITY OF SURREY the future lives here.</p>			Approved By :  APRIL 2020 G.M. Engineering
CITY CENTRE STANDARD DRAWINGS			DRAWING NUMBER CCSD-14d

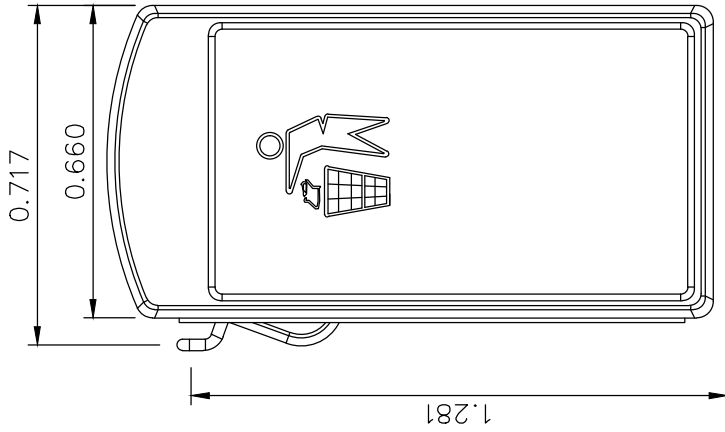

LEFT SIDE VIEW
NTS

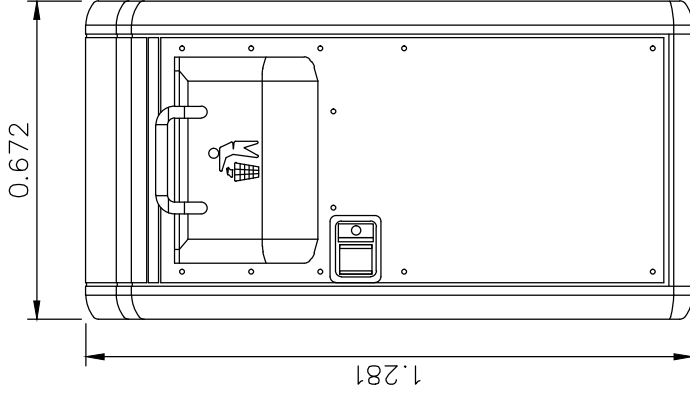

FRONT SIDE VIEW
NTS

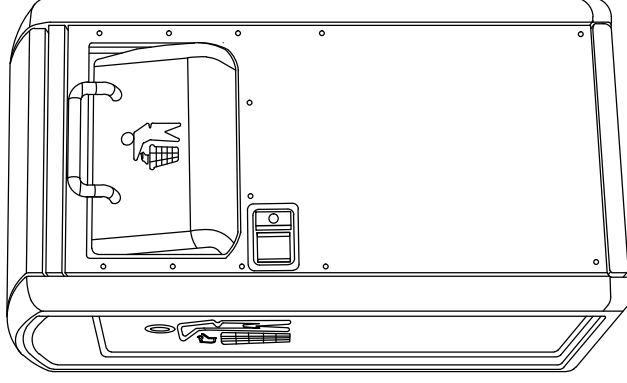

ISOMETRIC VIEW
NTS

3		All Dimensions Shown in Metres, Unless Otherwise Noted	
2		Title TYPICAL TRASH CAN (BIG BELLY)	
1		APRIL 2020	Approved By :
		Revision Date	DRAWING NUMBER CCSD-14e
		APRIL 2020 G.M. Engineering	
		CITY OF SURREY the future lives here.	
		CITY CENTRE STANDARD DRAWINGS	

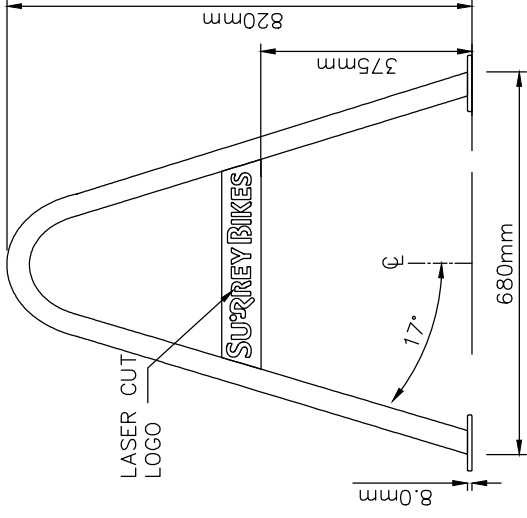

13.5mm X
75mm

100mm

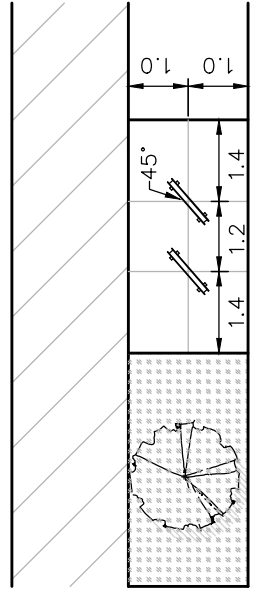
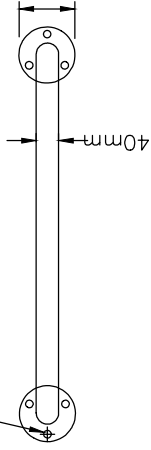

SPECIFICATIONS

- BICYCLE CAPACITY 2
- RECOMMENDED SPACING 1.2m OC
- MINIMUM SPACING 0.9m OC
- LONGITUDINAL SPACING 3.0m OC
- ASSEMBLY MATERIAL MILD STEEL (STAINLESS 304)
- TUBE SIZE 40.0mm
- WALL THICKNESS 3.0mm
- LOGO BAR 4.0mm PLATE
- WEIGHT 8.4KG
- FINISH POWDER COATED OVER ZINC PRIMER #4 POLISH (STAINLESS STEEL ONLY)
- ANCHOR TYPE CONCRETE WEDGE ANCHOR 13mm X 75mm GALVANIZED (STAINLESS) OPTIONAL BREAKAWAY NUTS

All Dimensions Shown in Metres,
Unless Otherwise Noted

Title		TYPICAL BIKE RACK
Approved By :		<i>[Signature]</i>
APRIL 2020	G.M. Engineering	

DRAWING NUMBER
CCSD-14f

3		
2		
1	APRIL 2020	S. NEUMAN
	Revision Date	Approved

CITY CENTRE
STANDARD
DRAWINGS

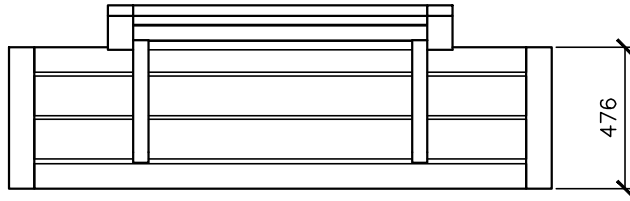

TOP

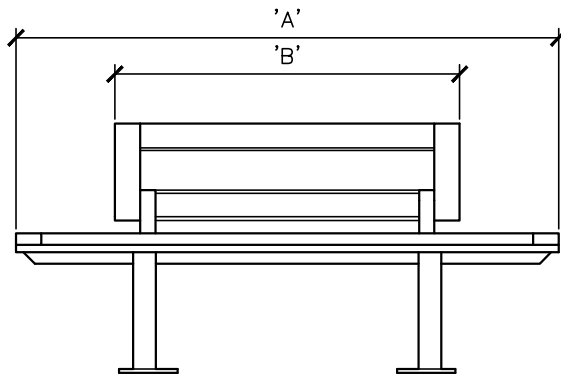

FRONT

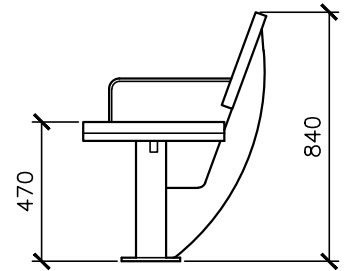

ELEVATION

BENCH SIZE	1.8m	2.4m	2.7m
'A'	1.829m	2.388m	2.743m
'B'	1.162m	1.734m	1.905m

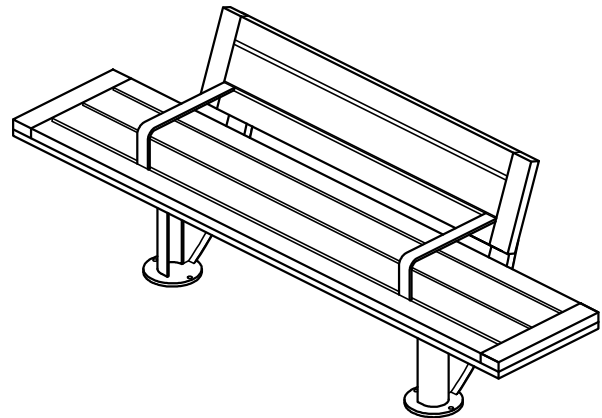

CITY STAFF TO SPECIFY
MATERIALS, COLOURS &
APPROVED MANUFACTURERS

3		
2	APRIL 2020	S. NEUMAN
1		
	Revision Date	Approved

All Dimensions Shown In Metres, Unless Otherwise Noted	
Title	BENCH DETAIL

CITY CENTRE
STANDARD
DRAWINGS

Approved By :

APRIL 2020 G.M. Engineering

DRAWING NUMBER
CCSD-14g

Apr 02 2020 - 8:27am G:\GENERAL\Design Criteria Manual & Supplementary\WICD\WICM and SHICD DRAFT 2020\SSD files\CCSD\14g BENCH DETAIL.dwg P206067

SURREY TYPICAL ORNAMENTAL GRASSES

BOTANICAL NAME	COMMON NAME
----------------	-------------

GRASSES, FESCUES AND SEDGES

CALAMAGROSTIS ACUTIFOLIA	FEATHER REED GRASS
CAREX VARIETIES	SEDGE
FESTUCA GLUACA	BLUE FESCUE
HELICOTOTRICHON	BLUE OAT GRASS
IMPERNATA CYLINDRA	JAPANESE BLOOD GRASS
MISCANTHA VARIETIES	SILVER GRASS
PANICUM VERIGATUM	SWITCH GRASS
PENNISETUM VARIETIES	FOUNTAIN GRASS
STIPA TENUISSIAN	FEATHER GRASS

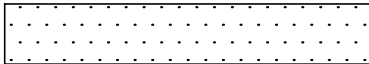

BOULEVARD GRASS PLAN VIEW

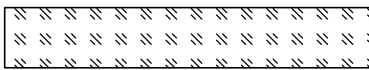



ORNAMENTAL GRASS PLAN VIEW



BOULEVARD GRASS SECTION VIEW



ORNAMENTAL GRASS SECTION VIEW

3		All Dimensions Shown In Metres, Unless Otherwise Noted			
2					
1	APRIL 2020	S. NEUMAN	Title ORNAMENTAL GRASSES		
	Revision Date	Approved			
 CITY OF SURREY the future lives here.			CITY CENTRE STANDARD DRAWINGS	Approved By :  APRIL 2020 G.M. Engineering	DRAWING NUMBER CCSD-15

Apr 02 - 2020 - 8:28am C:\GENERAL\Design Criteria Manual & Supplementary WICD\CDM and SIMCD DRAFT 2020\SSD files\CCSSD\15 Ornamental Grasses.dwg/15 P206067